

WINGCO[®] GENERATORS

WL22000VE/C 19,000 RUNNING WATTS

Rugged Steel Design.



B & S Commercial Vanguard Engine.

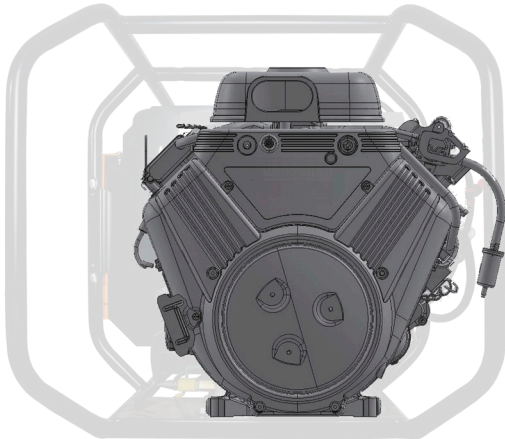

Brushless Industrial Genend.

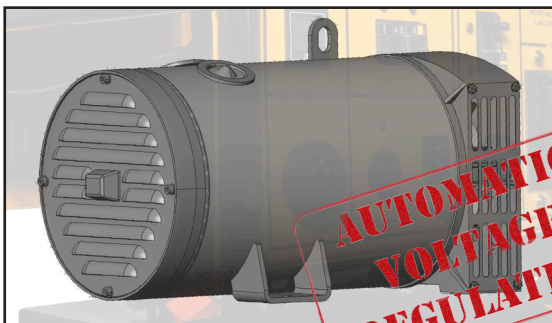

**AUTOMATIC
VOLTAGE
REGULATION**

 An American Company.

We produce our products in our 200,000ft² facility located in Le Center, Minnesota, equipped with modern engineering, fabrication and assembly capabilities.



YOURGEN



LED Display

Hours, RPMs, voltage, and frequency readings automatically cycle on the display.

Load Bars

Easily verify the load balance on each leg of the generator end.

Warnings

The LED will flash if any parameter gets outside of normal range. A warning will also be displayed when it is time for an oil change.

Receptacle Panel

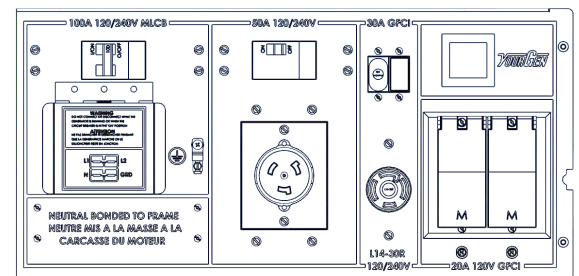

SPECIFICATIONS

ENGINE

ENGINE BRAND	BRIGGS & STRATTON
ENGINE MODEL	VANGUARD
ENGINE STARTER	ELECTRIC
ENGINE SPEED	3600 RPM
ENGINE CYLINDERS	V-TWIN
DISPLACEMENT/TYPE	993 CC / OHV
FREQUENCY REGULATION ⁽¹⁾	+/-1.5%
LOW OIL PROTECTION	STANDARD
RECOMMENDED OIL ⁽²⁾	10W-30
OIL CAPACITY	2.3 QT
FUEL TANK	15 GAL
FUEL GAUGE	YES
FULL LOAD RUN TIME ⁽³⁾	4.5 HOURS
FUEL CONSUMPTION	GAL/HR
100%	3.28
75%	2.57
50%	1.88
25%	1.43
0%	0.95
BATTERY SIZE ⁽⁴⁾	BCI GROUP 26 500CCA

NOTES: (1) Steady state frequency regulation. (2) The recommended oil is for normal applications. See operator's manual for the recommended oil for your needs. (3) Run time is estimated. (4) Battery not included.

OPTIONAL ACCESSORIES

FOUR-WHEEL DOLLY KIT	WITH FLAT-FREE TIRES
COVER	45" x 32" x 30"
50A PLUG	CS6365C
30A PLUG	NEMA L14-30P
BATTERY	BCI GROUP 26 500 CCA
MAINTENANCE KIT	16200-011

ELECTRICAL

STARTING WATTS	22,000
RUNNING WATTS	19,000
RUNNING AMPS @ 120 VAC	158.3
RUNNING AMPS @ 240 VAC	79.2
VOLTAGE REGULATION	AVR +/- 1.5%
MAIN CIRCUIT BREAKER	100 AMP, 120/240V
BONDED NEUTRAL	YES
120 VOLT RECEPTACLES	(2) NEMA 5-20 20A DUPLEX (GFCI)
120/240 VOLT RECEPTACLES	(1) CS6365 50A (1) NEMA L14-30 30A (GFCI)
120/240 VOLT ANDERSON	120A
YOURGEN METER	STANDARD

WL22000VE

MOTOR STARTING (CODE G)	6 HP
DBA @ 7 METERS	79
TOTAL HARMONIC DISTORTION	< 6%
LIFTING EYE ⁽¹⁾	STANDARD
4-WHEEL DOLLY KIT	OPTIONAL
INSULATION	CLASS H
PROTECTIVE ROLL FRAME	1.25" DIA. 14 GA. STEEL
ASSEMBLED IN	USA
EPA APPROVED	YES
CARB APPROVED	NO
TÜV CSA CERTIFICATION	NO
UNIT WARRANTY ⁽²⁾	3 YEARS COMMERCIAL

NOTES: (1) Shipping eye shipped loose. (2) For more generator warranty, see operator's manual.

SHIPPING

SHIPPING DIMENSIONS (L x W x H)	44" x 31" x 37"
SHIP WEIGHT	504 LBS
FREIGHT CLASS	70

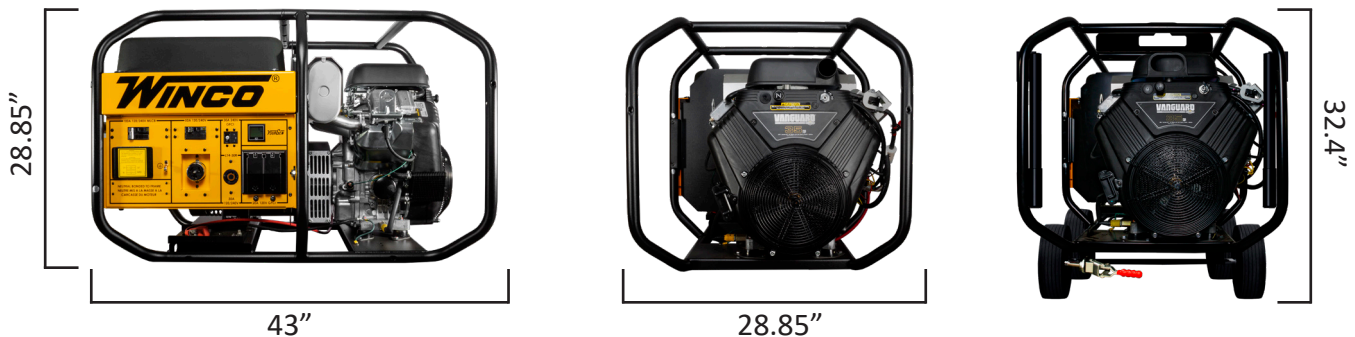

Specifications are subject to change without notice.

