

WINCO[®]

**W10PTOS/A
W15PTOS/F
GENERATORS**



INSTALLATION AND OPERATORS MANUAL

WINCO INC. 225 S. CORDOVA AVE. LE CENTER, MN 56057 507-357-6821
SERVICE DEPT. 507-357-6831
www.wincogen.com

TABLE OF CONTENTS

SAVE THESE INSTRUCTIONS

INTRODUCTION

SPECIFICATIONS

W10PTOS

W15PTOS

SAFETY

IMPORTANT SAFETY INSTRUCTIONS

ANSI SAFETY DEFINITIONS

TESTING POLICY

PREPARING THE UNIT

UNPACKING

INSTALLATION

FOUNDATION MOUNTING

TRAILER MOUNTING

THREE-POINT HITCH KIT

ELECTRICAL CONNECTIONS

PRE-START CHECKS

GENERATOR STARTING PROCEDURE

STORAGE & MAINTENANCE

MAINTENANCE REQUIREMENTS

TROUBLE SHOOTING TABLE

WIRING DIAGRAMS

12 MONTH LIMITED WARRANTY

COPY YOUR MODEL AND SERIAL NUMBER HERE

No other WINCO generator has the same serial number as yours.

If you should ever need to contact us on this unit, it will help us to respond to your needs faster.

2

3

MODEL _____

3

SERIAL NUMBER _____

3

PURCHASE DATE _____

DEALER NAME _____

4

DEALER PHONE # _____

4

4 SAVE THESE INSTRUCTIONS

This manual contains important instructions that should be followed during installation and maintenance of the generator. Read and understand all instructions in the manual before starting and operating the generator.

5

7

USING THIS MANUAL

8

8

Congratulations on your choice of a WINCO generator. You have selected a high-quality, precision-engineered generator designed and tested to give you years of satisfactory service.

9

To get the best performance from your new generator, it is important that you carefully read and follow the operating instructions in this manual.

10

12

Should you experience a problem please follow the "Troubleshooting Tables" near the end of this manual. The warranty listed in the manual describes what you can expect from WINCO should you need service assistance in the future.

INTRODUCTION

The WINCO rotating field power take-off generators are designed primarily for hobby/small farm use as a standby electrical power supply, utilizing the power take-off of a tractor or truck as the prime mover. This PTO drive generator will provide 120/240V single phase, 60Hz electrical service when properly driven.

NOTE: The prime mover which drives the generator must be capable of delivering approximately 2 HP per 1000 watts output from the generator. Observe input RPM specifications.

This generator may be mounted in many different fashions. The three most popular are foundation mounted, trailer mount or 3-point hitch mounted. Your application will dictate how you may want to mount it.

This generator includes a color coded voltmeter to warn against high or low voltage, and two output power receptacles with individual circuit breakers for your protection. To reduce maintenance problems, the coupling between the generator input shaft and rotor consists of precision helical gearing rather than a chain link drive.

IMPORTANT:

THE MANUFACTURER STRONGLY RECOMMENDS RUNNING THE GENERATOR UNDER LOAD AT LEAST ONCE A MONTH IN ORDER TO EVAPORATE ANY ACCUMULATED MOISTURE CONDENSATION AND TO KEEP THE UNIT IN GOOD WORKING ORDER.

SPECIFICATIONS

W10PTOS

Watts	10,000
Amps	41.6
Input Speed	515 RPM
Generator Speed	3600 RPM
Input Shaft	1 3/8" - 6 spline
Required Tractor PTO HP	20
Gear Lube	
Volume	16 oz
Type	85/90W-140

W15PTOS

Watts	15,000
Amps	62.5
Input Speed	515 RPM
Generator Speed	3600 RPM
Input Shaft	1 3/8" - 6 spline
Required Tractor PTO HP	30
Gear Lube	
Volume	16 oz
Type	85/90W-140

SAFETY

IMPORTANT SAFETY INSTRUCTIONS

SAVE THESE INSTRUCTIONS

This manual contains important information that should be understood and followed before the installation, operation and maintenance of the generator. Failure to follow the safety instructions in this manual could result in serious injury or death. Keep this manual available for future reference.

ANSI SAFETY DEFINITIONS

DANGER:

DANGER indicates an imminently hazardous situation which, if not avoided, will result in death or serious injury. This signal word is to be limited to the most extreme situations.

WARNING:

WARNING indicates a potentially hazardous situation which, if not avoided, could result in death or serious injury.

CAUTION:

CAUTION indicates a potentially hazardous situation which, if not avoided, may result in minor or moderate injury. It may be used to alert against unsafe practices.

NOTE: CAUTION is also used on the unit labels and in this manual to indicate a situation that could result in serious damage or destruction of the equipment and possible personal injury.

1. ELECTRIC SHOCK -

The output voltage present in this equipment can cause a fatal electric shock. This equipment must be operated by a responsible person.

- A. Do not allow anyone to operate the generator without proper instruction.
- B. Guard against electric shock.
- C. Avoid contact with live terminals or receptacles.
- D. Use extreme care if operating this unit in rain or snow.
- E. Use only three-prong grounded plugs and extension cords.
- F. Be sure the unit is properly grounded to an external ground rod driven into the earth.

2. FIRE HAZARD -

- A. Keep a fire extinguisher nearby and know its proper use. Fire extinguishers rated ABC by NFPA are appropriate.

3. NOISE HAZARD -

Excessive noise is not only tiring, but continual exposure can lead to loss of hearing.

- A. Use hearing protection when working around this equipment for long periods of time.

- B. Keep your neighbors in mind when permanently installing this equipment.

4. CLEANLINESS -

Keep the generator and surrounding area clean.

- A. Remove all grease, ice, snow or materials that create slippery conditions around the unit.
- B. Remove any rags or other materials that could create a potential fire hazard.
- C. Carefully clean up any gas or oil spills before starting the unit.

5. SERVICING EQUIPMENT -

All service, including the installation or replacement of service parts, **should be performed only by a qualified technician.**

- A. Use only factory approved repair parts.
- B. Do not work on this equipment fatigued.
- C. Use extreme caution when working on electrical components. High output voltages from this equipment can cause serious injury or death.
- D. Installing a generator is not a “do-it-yourself” project. Consult a qualified, licensed electrician or contractor. The installation must comply with all national, state, and local codes.

6. INSTALLATION -

Installing a PTO generator is not a “do-it-yourself” project. Consult a qualified, licensed electrician or contractor. The installation must comply with all national, state, and local codes.

- A. Never operate the PTO drive generator without having it properly mounted to a concrete base or approved trailer.
- b. Never connect the PTO generator to an existing electrical system without installing an isolation transfer switch.
- C. Always insure the drive shaft is straight and level before operating the generator.

8. OPERATION - PTO drive shafts (tumbling bars) have many inherent dangers, extreme caution must be exercised when using them.

- A. NEVER allow children around the drive shaft when it is in operation.
- B. Keep all safety guards and shields in place and securely tightened.
- C. Never operate a drive shaft that has been damaged or had the safety shield removed.
- D. Never step over a drive shaft while it is running.
- E. Never wear a necktie, loose articles of clothing, or anything else that can be caught in moving parts.
- F. Never try to stop drive shaft with your hand or your foot.

TESTING POLICY

Before any generator is shipped from the factory, it is fully checked for performance. The generator is loaded to its full capacity, and the voltage, current, and frequency are carefully checked.

Rated output of generator is based on engineering tests of typical units, and is subject to, and limited by, the temperature and altitude.

PREPARING THE UNIT UNPACKING

CAUTION: EQUIPMENT DAMAGE

When you unpack your new generator, be sure to remove all of the information sheets and manual from the carton.

1. As you receive your unit, it is critical to check it for any damage. If any damage is noted, it is always easiest to refuse the shipment and let WINCO take care of the freight claim. If you sign for the unit, the transfer of the ownership requires that you file the freight claim
2. Before proceeding with the preparations of your new generator for operation, take a couple of minutes to ensure the unit you have received is the correct model and review the specification pages in this manual to ensure that this unit meets your job requirements.

INSTALLATION FOUNDATION MOUNTING

Mount the generator on a foundation if it is to be used as a permanent or standby power source. When planning a foundation consider the following points:

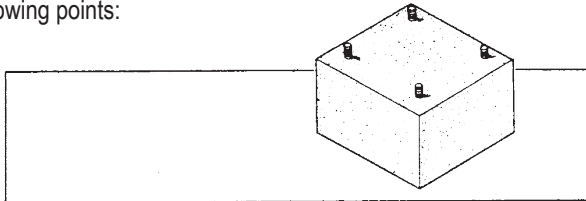

- A. The foundation location should enable aligning the drive shaft (tumbling bar) in a straight or nearly straight line between the power take-off and the generator input shaft. Misalignment must be less than 5 degrees during generator operation, even though the mechanical design of the tumbling bar would allow greater misalignment.
- B. The foundation must be solid enough to absorb generator starting and reflected load torque during operation.
- C. The foundation surface should be flat.
- D. Space is required around the generator for mounting switching devices, making connections, and for servicing.

E. For dimensions needed for install for your specific generator, please refer to it's outline drawing. The hardware needed is dependent on your distinct application.

F. The generator mounting bracket must rest evenly and firmly on the foundation. Install shims if necessary to even out the foundation under the mounting pads then bolt the generator firmly in place.

TRAILER MOUNTING

Optional Trailer Part Number TDM76

Mount the generator on a trailer if you plan to use it as a portable power source. When selecting or building a trailer to mount the generator, consider the following points:

- A. The trailer construction must be strong enough to support the generator.
- B. The design of the trailer must enable the trailer to remain stable during operation, and to resist tipping caused by generator starting and reflected load torque.
- C. The trailer height and mounting position of the generator on the trailer should enable aligning the drive shaft (tumbling bar) in a straight or nearly straight line between the power take-off and generator input shafts. Misalignment must be less than 5 degrees during generator operation, even though the mechanical design of the tumbling bar would allow greater misalignment.
- D. The generator mounting area of the trailer bed should be flat.

All four generator mounting pads must rest firmly on the trailer bed. Install shims if necessary to even out the bed under the mounting pads, then bolt the generator firmly in place.

WARNING: PERSONAL INJURY & EQUIPMENT DAMAGE

Trailer may tip over and cause injuries if wheels are not spaced far enough apart.

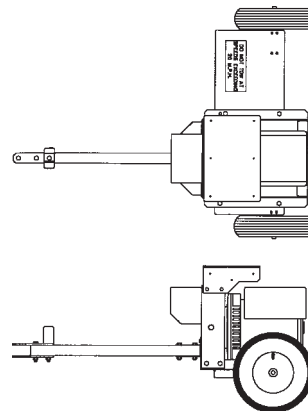

THREE-POINT HITCH KIT

Optional 3-Point Hitch Part Number TPH241

WARNING: PERSONAL INJURY & EQUIPMENT DAMAGE

When using the 3-point hitch assembly all three points must be attached to the tractor. Failure to do so will cause the generator to tip when lifting it damaging both the t-bar and the generator.

A. The three point hitch must be attached to the tractor at all times during operation.

B. When operating the generator the three point hitch and generator must be sitting on flat level ground. All four deck pads must be in constant contact with the ground at all times. This will reduce the vibration in both the generator and the tumbling bar.

C. For safety the generator must be bolted to the three point hitch deck using all four mounting bolts.

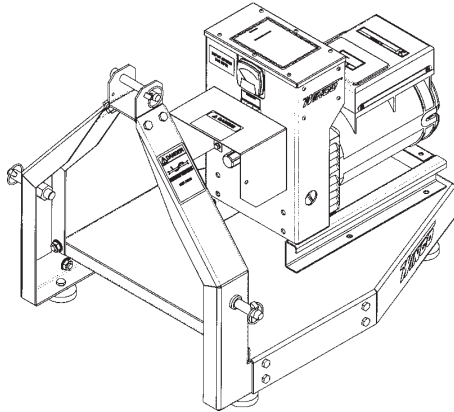

ELECTRICAL CONNECTIONS

CAUTION:

Only qualified electricians should install electrical wiring. Wiring must conform to all applicable national, state, and local codes. (Reference: National Fire Protection Association Manual No. 70, National Electrical Code.)

DANGER: PERSONAL INJURY:

If the generator is to be used as a standby power source,, a manual transfer switch must be installed to separate the generator and the commercial power lines. The switch must isolate the generator from the commercial power lines and the load when the generator is on standby, and must isolate the commercial power lines from the load and the generator when the generator is supplying power. See the following diagrams.

A properly rated and installed double throw manual power isolation transfer switch must be used with a standby generator. The transfer switch isolates the load from the power line and allows you to safely operate your loads without endangering the power line repair crew. See previous diagrams

The load, connected to the normal terminals of the transfer switch, is energized by the normal power line when the switch is in the normal position. The generator, connected to the emergency terminals of the switch, furnishes power when the switch is in the emergency mode position.

There are two ways to install a manual transfer switch. The first is to install the switch between the watt-hour meter and the normal distribution panel. As with any system you must install an entrance rated breaker before the manual transfer switch. The manual transfer

switch must in all cases be equal to or greater than the rating of the entrance rated breaker.

The second way to install the system is to purchase and install an emergency distribution panel and move the circuits you wish to back up to the new distribution panel. In this case the manual transfer switch only has to be sized to the amperage of the circuit breaker in the main distribution panel that is feeding it.

Before deciding which system to install, first determine which loads you can safely run on your PTO generator and the cost of buying a large manual transfer switch versus the cost of a smaller switch and the additional distribution panel.

The final item that you are going to have to assemble/wire is the plug that will be used to connect the generator to the manual transfer switch. You should have found this load plug in a small box when you unpacked the PTO generator. If you need additional plugs for multiple sites you can order additional plugs from your Winco dealer, the part number is "300137".

WARNING: PERSONAL INJURY:

Disconnect power before wiring.

IMPORTANT:

Use copper wire only. Do NOT use tinned conductors. Sizing cable - see NEC 400-5

Cord size: #4/4 conductor cord SO, 1.25" dia. max.

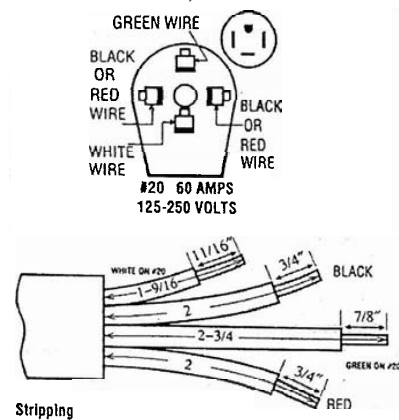

To assemble and wire the load disconnect plug, proceed as follows:

1. Strip outer jacket 2-3/4".
2. Cut and strip leads to lengths specified for the particular plug.
3. Disassemble cable clamp and top cover.
4. Remove one blade at a time, insert the stripped end of the appropriate colored wire designated above, and tighten the set screw.
5. Fit blades through slots in bottom cover and push down until home. Please note: Make sure blades are in correct slots and oriented in accordance with the diagram above or you will not be able to close the top cover fully.
6. Place top plastic cover over assembly and partially tighten the bakelite assembly screw. Realign blades straight (so they fit into the top bakelite housing properly) and tighten the assembly screw.

7. Assemble cable clamp over the outer jacket of the wire and tighten the two clamp screws. Special Note: For small size round (less than 3/4") and flat cables, the wire clamp may be inverted.

WARNING: PERSONAL INJURY:
Failure to wire as instructed may cause personal injury or damage to device or equipment. To be installed or checked by an electrician or qualified person only.

Typical Connection Methods for Generator Power Service

TYPICAL INSTALLATION FOR SUPPLYING ALL CIRCUITS WITH EMERGENCY POWER

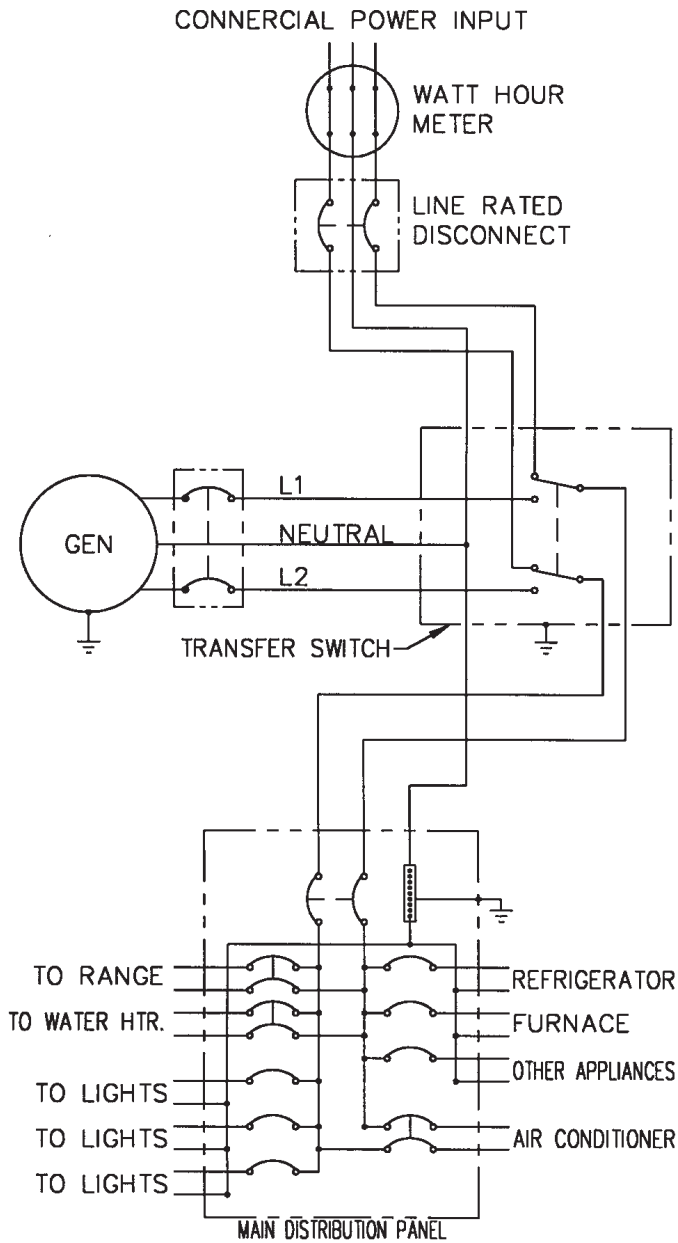

TYPICAL INSTALLATION FOR SUPPLYING ONLY ESSENTIAL CIRCUITS WITH EMERGENCY POWER

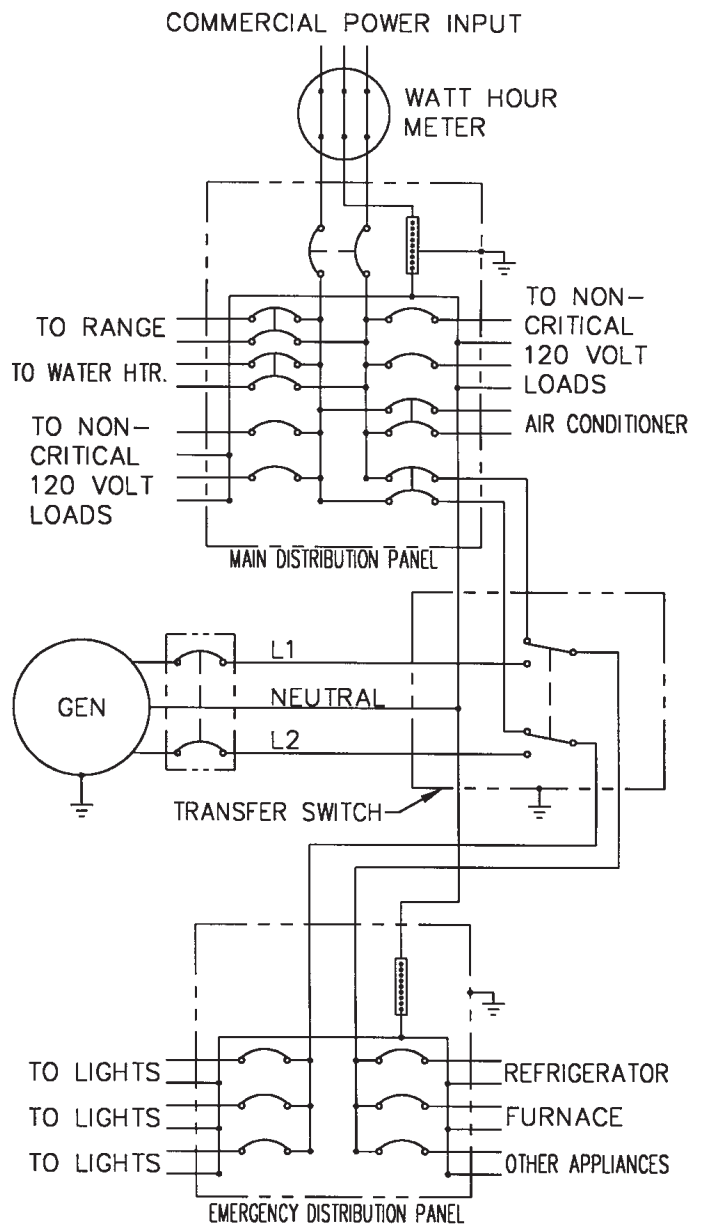

PRE-START CHECKS

WARNING: PERSONAL INJURY:

When working on or around these generators, do NOT wear loose fitting clothing or any articles that may get caught in moving parts.

1. Visually inspect the generator. Check for:
 - a. Correct mounting.
 - b. Physical damage.
 - c. Debris in cooling vents and screens. (Could cause generator to overheat)

IMPORTANT:

The manufacturer recommends that, if the generator has been stored for any length of time, before using it, the operator remove the control box cover and cooling fan screen, then inspect the generator for rodent nests or other objects that could cause generator binding and/or overheating. See 'Cleaning' portion of the Maintenance section.

2. Check Gearcase oil level. (See drawing) Case should be filled with oil to plug marked 'OIL LEVEL'. Fill or remove oil as required.

NOTE: Either too little or too much oil can harm the equipment.

See 'Lubrication' portion of Maintenance for oil specifications.

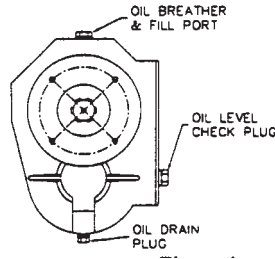

3. Make sure the drive shaft (tumbling bar) is assembled with its universal joint knuckles "synchronized," as illustrated in Figure 7. If knuckles are not synchronized, the bar will chatter when rotating, which will cause the generator output voltage to flicker. Drive shafts shipped new from Winco are always synchronized and tethered so they can not be taken apart.

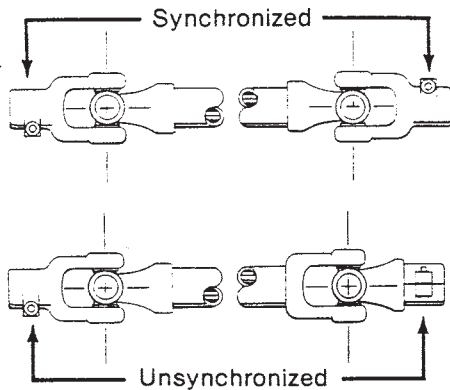

DANGER: PERSONAL INJURY:

Power take-off must be disengaged at this time.

4. Couple the tractor to the generator with the drive shaft (tumbling bar). Couple the tumbling bar to the generator input shaft first, then to the power take-off shaft. Check alignment, tractor, power take-off shaft (tumbling bar), and generator input shaft should form a straight (or nearly straight) line, with less than 5° misalignment between the shafts. Misalignment will cause generator output voltage to flicker.

WARNING: PERSONAL INJURY:

Make sure that all tumbling bar lock pins are engaged and that all safety shields are in place before operating the PTO generator.

5. Make sure no binding exists in generator or gear box. If binding is found, locate the cause and correct it before proceeding.
6. Make sure that the electrical loads to be driven by the generator will not draw more current than the ratings of the generator receptacle or cord set which will supply the current.
7. Check all electrical connections in the system to be energized by the generator. Make sure the connections are correct and are tight.
8. Make sure all loads are turned off. Do not start the generator under load.
9. Verify any special conditions specific to your application.

GENERATOR STARTING PROCEDURE

1. Set the manual transfer to mid or normal (up) position.
2. With the power take-off drive disengaged, start the engine which will drive the generator. Run the engine long enough to warm it up before proceeding, so that it will run smoothly and achieve full power under generator load.
3. With engine idling, engage the power take-off drive.
4. Watch the voltmeter on the generator and slowly increase engine speed until the output reaches approximately 240 to 245 volts, in green portion of voltmeter scale.

CAUTION: EQUIPMENT DAMAGE:

Most electrical equipment in North America operates satisfactorily at frequencies between 59 and 61 Hz (cycles per second). Operating the generator at frequencies outside that range may cause damage to the generator and/or to electrical equipment driven by the generator.

5. Plug 4 wire load cord set into receptacle. Place transfer switch in the emergency position.
6. Place the load circuit breaker in the "on" position. If the breaker trips, move manual transfer switch to "off" or normal position. Check for short circuit or grounded connection in the load cable to the double throw switch and repair. A breaker that trips from overload or short circuit must be reset by moving to "off" before re-closing.
7. With engine and generator running smoothly, switch on the electrical load while watching the voltmeter. Readjust engine throttle to keep generator output under load at 240V (in green portion of voltmeter scale). If engine is equipped with speed governor, it may automatically readjust the throttle as the load changes and keep the generator output at the proper level. However, some governors are not sensitive enough to maintain proper output under changing load, and in such cases the throttle will have to be manually readjusted.

NOTE: EQUIPMENT DAMAGE:

If the load includes motors turn them on one at a time, highest starting current motor first, next highest second, etc

8. The return of normal power will be indicated by the lamp on the front of transfer switch; (applicable only when the transfer switch is equipped with indicating lamps or your electrician has installed them). After sufficient time to assure that power restoration isn't temporary, return the transfer switch to normal power (10 - 20 minutes).

9. Place the alternator circuit breaker in "off" position. Do not remove plug before opening the breaker.

10. Slowly reduce power take-off speed to a minimum and disengage the power take-off. Some tractors have a brake on the power take-off that stops the shaft instantly. Stopping the alternator rotor instantly from rated speed may result in a broken shaft or other drive line failures.

WARNING: PERSONAL INJURY:

Never try to manually stop the generator. Always let it coast until it stops.

11. Shut off the engine.

12. Disconnect drive shaft (tumbling bar) power take-off end first, then generator end.

STORAGE & MAINTENANCE

If the generator is mounted on an off-highway trailer, such as the Winco trailer, it should be stored in a garage, barn or machine shed in a dry and clean location. The generator should be covered with a tarp to prevent the entrance of dust, chaff, and/or moisture.

The generator may be stored on end (as pictured), provided the generator is on a clean, dry elevated surface such as a board. Do not have it resting on a dirty surface.

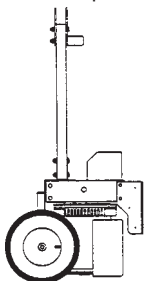

MAINTENANCE REQUIREMENTS

LUBRICATION

A. Check the generator gear case oil level before each use of the generator. See Figure 4. Maintain the oil level before each use of the generator. Maintain the oil level at oil level plug height. The generator is shipped with lubricant in the gear case. Specifications for gear case lubricant are: API Service: GL-5 EP Rated, Grade: SAE 85W-90-140, Amount: 1 pint.

The following kinds of oil are recommended for use in the generator gear case:

- Mobil SAE 85W90-140 API Service GL-5
- Sunoco/DX XL80W90-140
- Kendal Three Star 85W-140
- Amoco 85W140 or equivalent

CAUTION: EQUIPMENT DAMAGE

Do not overfill generator gear case. Overfilling causes overheating and oil seal failure.

B. The generator bearings are factory lubricated and sealed, and require no further lubrication.

C. The splined generator input shaft should be cleaned and lubricated with a thin film of grease before and after each use of the generator. See Figure 6 for lubrication schedule.

D. The drive shaft (tumbling bar) requires greasing. Keep the universal joints in the coupling shaft free from grease and dirt buildup.

E. Exercise PTO alternator for one hour under load at least twice a year.

NOTE: Do not over lubricate the universal joints.

CLEANING

WARNING: Equipment Damage:

Do not clean the generator while it is running.

A. Inspect for loose or broken wiring connections. Make sure that wiring connections are not loose at the generator end, circuit breakers, and receptacles.

B. Do not allow dirt or chaff to collect in the interior of the generator or the ventilation openings. Inspect for indication of the entrance of mice or insects into the generator. The inlet and outlet openings are louvered, but possible damage to the louvers could occur. Mice can destroy the generator winding.

TROUBLE SHOOTING TABLE

SYMPTOM	POSSIBLE CAUSE	CORRECTIVE ACTION
Low Output Voltage	<ol style="list-style-type: none"> 1. Undersized/overloaded. 2. Defective governor. 3. Low power - worn engine. 4. High line loss. Indicated by lower voltage at load than at generator terminals. 5. Shorted or grounded rotor coil. 6. Defective stator. 7. Underspeed 	<ol style="list-style-type: none"> 1. Check for overload on the tractor or undersized. 2. Check tractor governor. Tight or defective throttle levers and joints. 3. Worn or defective tractor engine. 4. Increase size of line wiring. Might also be the result of loose connection indicated by excessive heating at the loose connection terminal. 5. Test and replace if defective. 6. Repair or replace as required. 7. Verify frequency is between 59-61 Hz
High Output Voltage	Generator is spinning too fast, slows prime mover down.	Readjust or replace as required.
Excessive Heating	Clogged ventilating inlet and/or outlet	Clean screens, make sure interior of generator is unobstructed.
No Output Voltage	<ol style="list-style-type: none"> 1. Broken or corroded connection 2. Defective diode(s) on rotor. 3. Open exciter circuit in stator. 4. Grounded or shorted rotor winding. 5. Loss of residual magnetism. Usually occurs only after disassembly of field frame or severe mechanical stress/abuse. 6. Shorted stator winding. This can be identified by the use of an internal "growler" at a competent rewinding shop. 7. Grounded stator. Check winding by test lamp or high potential tester from stator leads to lamination. 8. Open stator circuit. Measure circuit between leads with an ohmmeter. Should have a circuit between any pair of leads. 9. Defective Capacitors. 	<ol style="list-style-type: none"> 1. Clean and tighten generator and receptacle connections. 2. Replace defective diode(s). 3. Repair or replace stator assembly. 4. Replace grounded rotor assembly. 5. Back flash the 120 Volt circuit with 12 Volts DC 6. Replace stator.)Include generator model and serial number on the order). 7. Same as #6. 8. Same as #6. 9. Test and replace if defective.
Voltage Unsteady/Lights Flickering	<ol style="list-style-type: none"> 1. PTO drive line off alignment. 2. Drive line knuckles out of sync. 	<ol style="list-style-type: none"> 1. Realign within 5 degrees. 2. Re-sync drive line halves.

WIRING DIAGRAMS

W10PTOS-3/A

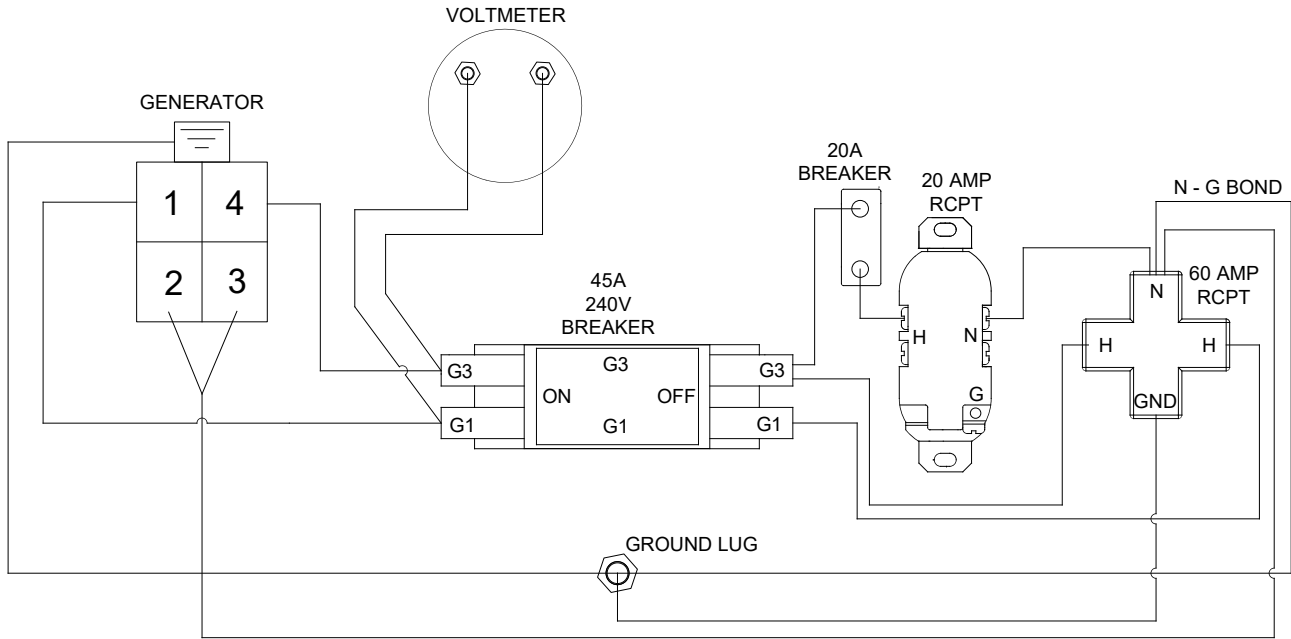

W15PTOS-3/E

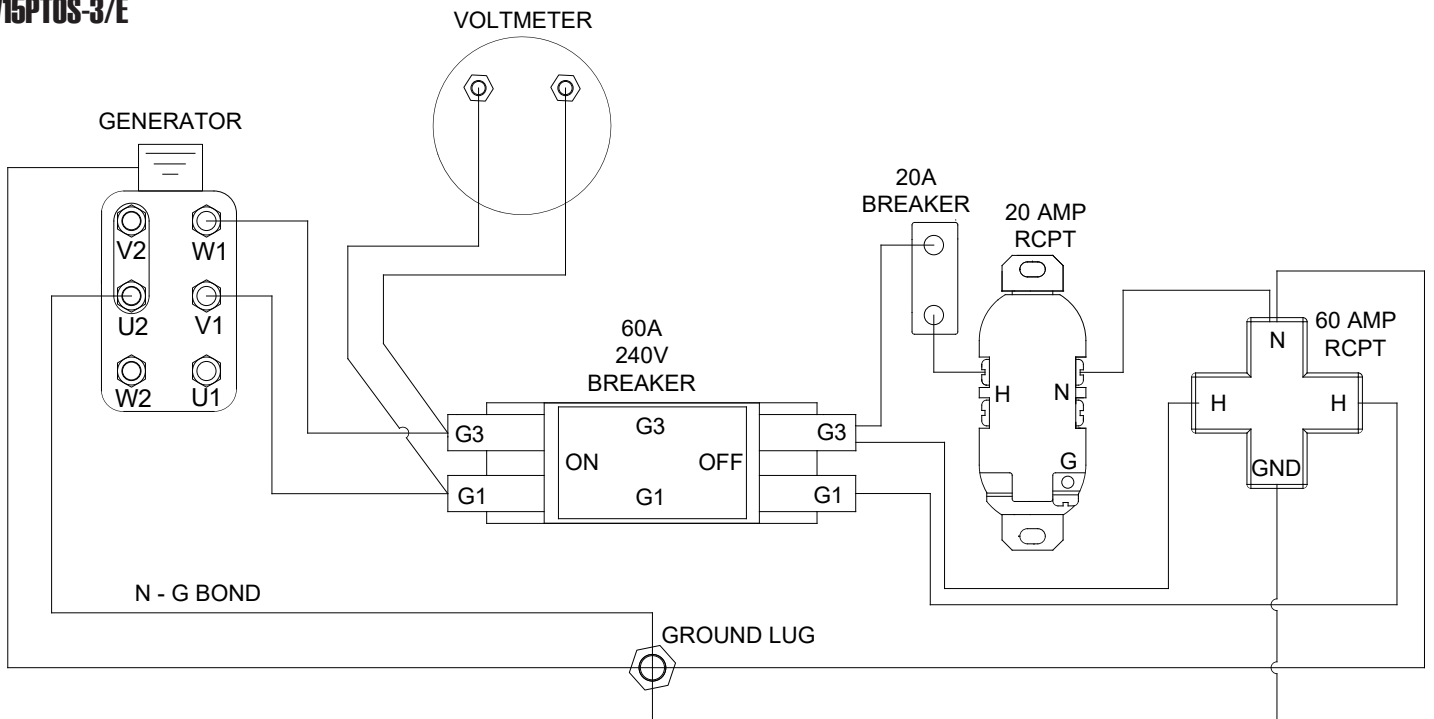



12 MONTH LIMITED WARRANTY

WINCO, Incorporated warrants to the original purchaser for 12 months or 1000 hours which ever occurs first, that goods manufactured or supplied by it will be free from defects in workmanship and material, provided such goods are installed, operated and maintained in accordance with WINCO written instructions.

WINCO's sole liability, and Purchaser's sole remedy for a failure under this warranty, shall be limited to the repair of the product. At WINCO's option, material found to be defective in material or workmanship under normal use and service will be repaired or replaced. For warranty service, return the product within 12 months or 1000 hours which ever occurs first from the date of purchase, transportation charges prepaid, to your nearest WINCO Authorized Service Center or to WINCO, Inc. at Le Center Minnesota.

THERE IS NO OTHER EXPRESS WARRANTY.

To the extent permitted by law, any and all warranties, including those of merchantability and fitness for a particular purpose, are limited to 12 months or 1000 hours which ever occurs first, from date of purchase. In no event is WINCO liable for incidental or consequential damages.

Note: Some states do not allow limitation on the duration of implied warranty and some states do not allow the exclusion or limitation of incidental or consequential damages, so the above limitations may not apply in every instance. This warranty gives you specific legal rights which may vary from state to state.

WINCO reserves the right to change or improve its products without incurring any obligations to make such changes or improvement on products purchased previously.

EXCLUSIONS:

WINCO does not warrant Engines. Engines are covered exclusively by the warranties of their respective manufacturers, see enclosed warranties.

WINCO does not warrant Component Parts that are warranted by their respective manufacturers.

WINCO does not warrant modifications or alterations which were not made by WINCO, Inc.

WINCO does not warrant products which have been subjected to misuse and/or negligence or have been involved in an accident.

This warranty does not include travel time, mileage, or labor for removal or re-installation of WINCO product from its application.