

WINCO[®] **GENERATORS**

EC6010DR/T EC6010KE-03/B GENERATORS

INSTALLATION AND OPERATORS MANUAL

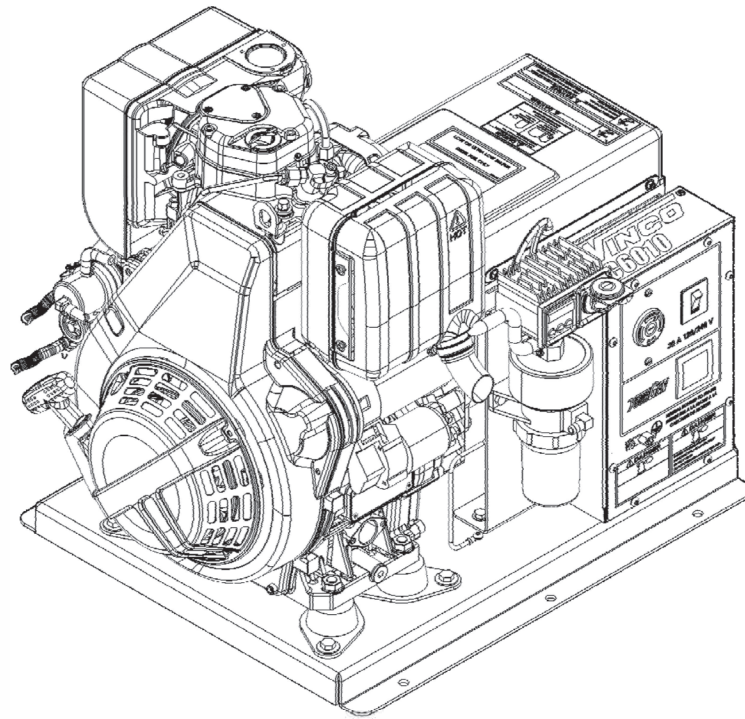

COPY YOUR MODEL AND SERIAL NUMBER HERE
No other WINCO generator has the same serial number as yours.
If you should ever need to contact us on this unit, it will help us to
respond to your needs faster.

MODEL _____

SERIAL NUMBER _____

PURCHASE DATE _____

DEALER NAME _____

DEALER PHONE # _____



TABLE OF CONTENTS

SAVE THESE INSTRUCTIONS

SAFETY

ANSI SAFETY DEFINITIONS

SPECIFICATIONS

GENERATOR

ENGINE

INTRODUCTION

TESTING POLICY

INTENDED USES

RESTRICTED USES

UNIT CAPABILITIES

GENERATOR CONNECTIONS

STARTING ELECTRIC MOTORS

LOAD TYPES

PREPARING THE UNIT

UNPACKING

COMPARTMENT INSTALLATION

LUBRICATION

OIL RECOMMENDATIONS

DIESEL FUEL

BATTERY INSTALLATION

CONTROL PANEL

FUEL PUMP

CONNECTING FUEL SUPPLY

INITIAL START UP

BASIC OPERATION

STARTING HINTS

STOPPING

CONNECTING THE LOADS

APPLYING THE LOADS

GROUNDING

WIRING

YOURGEN

ENGINE CARE

MAINTENANCE SCHEDULE

CHANGING THE OIL

CHECKING THE OIL LEVEL

AIR FILTER

GENERATOR CARE

EXERCISING THE GENERATOR

GENERATOR MAINTENANCE

CLEANING

TROUBLESHOOTING

CONTROL PANEL WIRING DIAGRAM

CA EVAP EMISSION CONTROL

LIMITED WARRANTY

2

3

4

USING THIS MANUAL

4

5

6

This manual contains important instructions that should be followed during installation and maintenance of the generator. Read and understand all instructions in the manual before starting and operating the generator.

Congratulations on your choice of a WINCO generator. You have selected a high-quality, precision-engineered generator designed and tested to give you years of satisfactory service.

To get the best performance from your new generator, it is important that you carefully read and follow the operating instructions in this manual.

Should you experience a problem please follow the "Troubleshooting Tables" near the end of this manual.

The warranty listed in the manual describes what you can expect from WINCO should you need service assistance in the future.

10

11

12

14

16

18

18

19

20

20

SAVE THESE INSTRUCTIONS

SAFETY

This engine generator set has been designed and manufactured to allow safe, reliable performance. Poor maintenance, improper or careless use can result in potentially deadly hazards; from electrical shock, exhaust gas asphyxiation, or fire. Please read all safety instructions carefully before installation or use. Keep these instructions handy for future reference. Take special note and follow all warnings on the unit labels and in the manuals.

CALIFORNIA PROPOSITION 65



WARNING: This product contains crude oil, gasoline, diesel fuel and other petroleum products, Antifreeze to which can expose you to chemicals including toluene and benzene, Ethylene glycol (ingested) which are known to the State of California to cause cancer, birth defects or other reproductive harm and developmental issues.
For more information go to www.P65Warning.ca.gov.

ANSI SAFETY DEFINITIONS

DANGER

Indicates an imminently hazardous situation which, if not avoided, will result in death or serious injury.

WARNING

Indicates a potentially hazardous situation which, if not avoided, could result in death or serious injury.

CAUTION

Indicates a potentially hazardous situation which, if not avoided, may result in minor or moderate injury. It may also be used to alert against unsafe practices.

1. ELECTRICAL SHOCK -

The output voltage present in this equipment can cause fatal electric shock. This equipment must be operated by a responsible person.

- A. Do not allow anyone to operate the generator without proper instruction.
- B. Guard against electric shock.
- C. Avoid contact with live terminals or receptacles.
- D. Use extreme care if operating this unit in rain or snow.
- E. Use only three-pronged grounded receptacles and extension cords.
- F. Be sure the unit is properly grounded to an external ground rod driven into the earth.

2. FIRE HAZARD -

Gasoline and other fuels present a hazard of possible explosion and/or fire.

- A. Do not refuel when the engine is running or hot.
- B. Keep fuel containers out of reach of children.
- C. Do not smoke or use open flame near the generator set or fuel tank.

- D. Keep a fire extinguisher nearby and know its proper use. Fire extinguishers rated ABC by NFPA are appropriate.
- E. Store fuel only in an approved container, and only in a well ventilated area.
- F. Follow local codes for closeness to combustible material.

3. DEADLY EXHAUST GAS -

Exhaust fumes from any gasoline engine contain carbon monoxide, an invisible, odorless and deadly gas that must be mixed with fresh air.

- A. Operate only in well ventilated areas.
- B. Never operate indoors including attached garages
- C. Never operate the unit in such a way as to allow exhaust gases to seep back into closed rooms (i.e. through windows, walls, floors).

4. NOISE HAZARD -

Excessive noise is not only tiring, but continual exposure can lead to loss of hearing.

- A. Use hearing protection when working around this equipment for long periods of time.
- B. Keep your neighbors in mind when using this equipment.

5. CLEANLINESS -

Keep the generator and surrounding area clean.

- A. Remove all grease, ice, snow or materials that create slippery conditions around the unit.
- B. Remove any rags or other materials that could create a potential fire hazard.
- C. Carefully clean up any gas or oil spills before starting the unit.

6. SERVICING EQUIPMENT -

All service, including the installation or replacement of service parts, should be performed only by a qualified technician.

- A. Use only factory approved repair parts.
- B. Do not work on this equipment when fatigued.
- C. Never remove the protective guards, covers, or receptacle panels while the engine is running.
- D. Use extreme caution when working on electrical components. High output voltage from this equipment can cause serious injury or death.
- E. Always avoid hot mufflers, exhaust manifolds, and engine parts. They can cause severe burns instantly.
- F. The use of the engine-generator set must comply with all national, state, and local codes.

SPECIFICATIONS

Model	EC6010DR/T EC6010KE-03/B
Starting Watts	6,010
Running Watts	
EC6010DR/T	5,160
EC6010KE-03/B	5,000
Volts	120/240
Starting Amps	50/25
Running Amps	
EC6010DR/T	43/21.5
EC6010KE-03/B	40/20

GENERATOR

Generator Manufacturer	Mecc Alte Spa
Generator Model Number	ES16F-160
Part Number	16346-027
Rotor Resistance	8.378 Ohms
Stator Resistance	0.51 Ohms
Regulation	AVR

ENGINE

Engine Manufacturer	Kohler
Engine Model Number	KD440
Fuel Type	Diesel
Oil Capacity	41.6 oz. (1.3 qts)

INTRODUCTION

TESTING POLICY

Before any generator is shipped from the factory, it is fully checked for performance. The generator is loaded to its full capacity, and the voltage, current, and frequency are carefully checked.

Rated output of generator is based on engineering tests of typical units, and is subject to, and limited by, the temperature, altitude, fuel, and other conditions specified by the manufacturer of applicable engines.

INTENDED USES

This engine generator set has been designed primarily for portable heavy duty commercial use. Both 120 volt and 240 volt receptacles are provided in the control panel to plug in your loads (lights, portable tools, and small appliances). These units are dual wound generators, therefore the 120 volt loads must be equally split with 1/2 of the rated capacity available on each of the two 120 volt circuits.

This portable unit requires large quantities of fresh air for cooling the engine and generator. For safety, long life and adequate performance, these units should never be run in small compartments without positive fresh air flow.

RESTRICTED USES

DO NOT operate generator where it could get wet or have pooling water near it. This generator is NOT weatherproof. Failing to keep generator in a dry area may cause an electrical shock, resulting in injury or death.

DO NOT operate and/or store the unit outside during inclement weather without adequate protection from the elements. Failure to do so will damage the unit.

DO NOT remove from the cradle assembly. Removal of the generator from the cradle assembly may cause excessive vibration and damage to the engine-generator set.

DO NOT install and operate this generator in a small compartment, i.e. generator compartments of vehicles, motor homes or travel trailers. These compartments will not allow enough free flow of fresh air to reach the engine generator set for cooling and will cause the unit to overheat, damaging both the engine and generator. Small compartments will also develop hot spots where there is very little air flow and may cause a fire.

PLEASE NOTE There are 3rd party companies making enclosures for generators that have been properly engineered. The use of these 3rd party enclosures is acceptable as long as they have been engineered and meet applicable code.

DO NOT attempt to operate at 50 cycles. These units are designed and governed to operate at 60 cycles only.

UNIT CAPABILITIES

GENERATOR CONNECTIONS

EC6010: 120 Volt and 240 Volt receptacles are provided for connection to various loads. The following diagram represents this 5,160 watt (rated output) generator. A & B represent the 120 volt output legs of this generator. Up to 2,580 watts at 120 volts (43 Amps) can be drawn from the receptacles attached to either A or B output legs. This generator is capable of producing 21.5 Amps of 240 volt current at C. Check the appliance or tool nameplates for the current and voltage to insure compatibility. Remember that power taken from C reduces the power available equally at both A and B and vice versa.

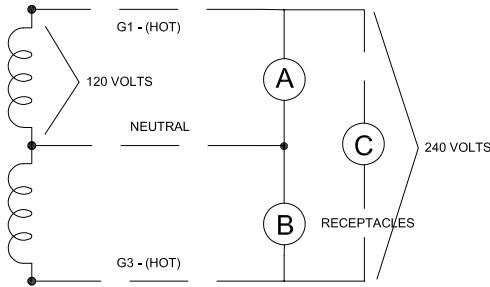

STARTING ELECTRIC MOTORS

Electric motors require much more current (amps) to start them than to run them. Some motors, particularly low cost split-phase motors, are very hard to start and require 5 to 7 times as much starting current as running current. Capacitor motors are easier to start and usually require 2 to 4 times as much starting current as running current. Repulsion Induction motors are the easiest to start and require only 1 1/2 to 2 1/2 times as much starting as running current.

Most fractional horsepower motors take about the same amount of current to run them whether they are Repulsion Induction (RI), Capacitor (Cap), or Split-Phase (SP) type. The following chart shows the approximate current required to start and run various types and sizes of 120 Volt 60 cycle electric motors under average load conditions.

HP	Running Amps	STARTING AMPS		
		Split Phase Motor	Capacitor Motor	Repulsion Induction Motor
1/6	3.2	16 to 22	6 to 13	5 to 8
1/4	4.5	22 to 32	9 to 18	7 to 12
1/3	5.2	26 to 35	10 to 21	8 to 17
1/2	7.2	Not Made	14 to 29	11 to 18
1	13	Not Made	26 to 52	20 to 33

The figures given in the previous chart are for an average load such as a blower or fan. If the electric motor is connected to a hard starting load such as an air compressor, it will require more starting current. If it is connected to a light load, or no load such as a power saw, it will require less starting current. The exact requirement will also vary with the brand or design of the motor.

Self-exciting generators respond to severe overloading differently than utility power. When overloaded, the engine

is not able to supply enough power to bring the electric motor up to operating speed. The generator responds with high initial starting current, but the engine speed drops sharply. The overload may stall the engine. If allowed to operate at very low speeds, the electric motor starting winding will burn out in a short time. The generator winding may also be damaged.

CAUTION: EQUIPMENT DAMAGE

Running the generator set under these conditions may result in damage to the generator stator as well as the motor winding.

The heavy surge of current required for starting motors is required for only an instant. The generator will not be damaged if it can bring the motor up to speed in a few seconds of time. If difficulty is experienced in starting motors, turn all other electrical loads off and if possible reduce the load on the electric motor.

Motor starting capacity - 2HP code 'G' capacitor start engine.

Trying to start a larger motor or higher code motor, i.e. 'J' or 'K', may result in damage to both the generator and the electric motor, especially 120 Volt motors.

LOAD TYPES

This generator is designed and rated for general commercial use. The running watts rating assumes a variable load. If your application has a fixed load that does not vary, an additional derate of 20% from the running watts is recommended to ensure the longest useful life of the engine and generator end.

PREPARING THE UNIT

UNPACKING

CAUTION: EQUIPMENT DAMAGE

Always check oil level prior to use. Failure to maintain the engine oil at the proper level will result in serious engine damage.

When you unpack your engine-generator set be sure to remove all the information sheets and manuals from the carton.

1. As you receive your unit, it is critical to check it for any damage. If any damage is noted, it is always easiest to refuse the shipment and let WINCO take care of the freight claim. If you sign for the unit, the transfer of the ownership requires that you file the freight claim
2. Before proceeding with the preparations of your new generator for operation, take a couple of minutes to ensure the unit you have received is the correct model and review the specification pages in this manual to ensure that this unit meets your job requirements.

COMPARTMENT INSTALLATION

When installing this generator in vehicle compartments it is essential that proper care is taken to prevent overheating. The following guidelines will help prevent these problems.

The easiest way to prevent overheating is to mount the generator on a slide out tray. This will move the generator into open air whenever it is in operation. A vertical opening door can also provide protection from rain during operation.

If the generator must be installed in an enclosed compartment during operation it is important to provide adequate cooling air flow.

This can cause air to recirculate and can result in generator overheating. The windings will fail prematurely in this scenario. Separate air intakes for the engine and generator can help reduce heat. The design should be tested with measurements taken for engine oil temperature and the generator stator windings. Contact WINCO for help in evaluating your application.

LUBRICATION

CAUTION: EQUIPMENT DAMAGE

Failure to maintain the engine oil at the proper level will result in serious engine damage.

Before starting the engine, verify the crankcase is filled to the proper level with a good quality oil. The recommended grade oil and quantity of oil required is listed in the engine operator's manual and under the service tab in this manual. This unit was shipped with oil in it. The engine normally holds 1.3 quarts (41.6 oz.) of oil. Use the dipstick to ensure that you have the proper oil level in the crankcase. The full

oil level mark on the dipstick is depicted in the following image.

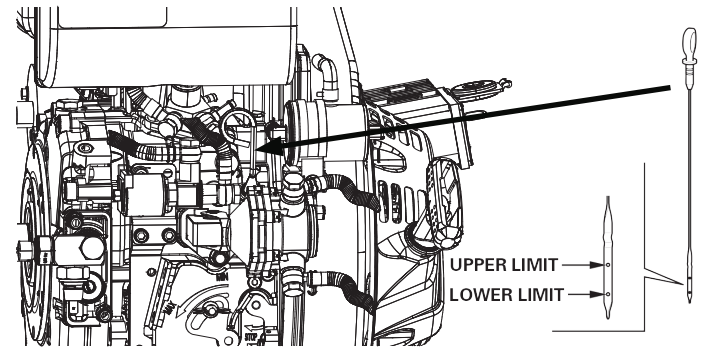

Oil is added to the engine by removing the oil cap and adding oil at this point. After filling the crankcase to the proper level, be sure you properly tighten the oil fill cap. NOTE: This engine generator must be on a level surface before you check or add oil to the system.

The necessity of using the correct oil and keeping the crankcase full cannot be overemphasized. Engine failures resulting from inadequate or improper lubricant are considered abuse and not covered by the generator or engine manufacturer's warranty.

OIL RECOMMENDATIONS

Outdoor temperatures determine the proper oil viscosity for the engines. Winco recommends our 5W-30 fully synthetic oil to give you excellent protection in cold temperatures while maintaining excellent performance in warmer weather.

F°	-40	-31	-22	-13	-4	5	14	23	32	41	50	59	68	77	86	95	104	113	122
C°	-40	-35	-30	-25	-20	-15	-10	-5	0	5	10	15	20	25	30	35	40	45	50
SAE 10W																			
SAE 20W																			
SAE 30																			
SAE 40																			
SAE 10W-30																			
SAE 10W-40																			
SAE 10W-60																			
SAE 15W-40*																			
SAE 15W-40**																			
SAE 20W-60**																			
SAE 5W-30***																			
SAE 10W-30***																			

DIESEL FUEL

Always use a good grade of # 2 diesel fuel. For cold weather, blended #1 fuel may be used. Fuel cetane number should be 45 or higher and the fuel MUST be low sulfur or ultra low sulfur fuel. See engine operators manual for additional fuel recommendations including Bio-Diesel fuel. Never use gasoline or gasohol. Always ensure that the fuel is clean and free of all impurities. Always be sure to keep the strainer in place when filling the fuel tank.

WARNING: FIRE DANGER

Diesel fuel is flammable and can be ignited, causing or enlarging fires when proper precautions are not taken.

Never use fuel that has been stored for an extended period of time. Fuel will lose its volatile properties and you will be left with a 'gum' or varnish residue. This varnish-like substance will clog the filters, fuel lines, and injectors. Old, contaminated, stale fuel will not burn properly. The use of a fuel additive, such as Sta-Bil, or an equivalent will minimize the formation of fuel gum deposits. If a unit has been out of operation for an extended period of time, it is best to drain old fuel from the engine and replace with fresh fuel before attempting to start.

BATTERY INSTALLATION

You will need to connect this unit to a battery to operate it. Cables have not been provided as length are going to vary depending on your installation. These engines are all negative ground. The positive battery cable must be connected to the open large terminal on the start solenoid (This terminal may have a small 16 GA. wire on it for the charging circuit). The negative cable should be attached to a good ground on the engine. This is usually one of the engine mounts.

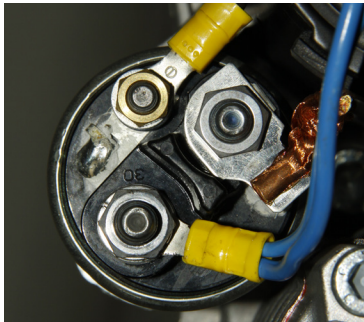

A twelve volt battery, rated at 300 CCA or larger is recommended for this electric start generator set. Follow the battery manufacturer's recommendations for servicing and charging prior to use.

CAUTION: EQUIPMENT DAMAGE:

These electric start engines are **NEGATIVE GROUND**. Use extreme caution when connecting the battery. Connect the **NEGATIVE** battery terminal to **GROUND**.

For your safety, always connect the positive battery cable to the "bat+" terminal first. Then connect the negative battery cable to the "Bat-" terminal. Make sure all connections are clean and tight. Reverse the sequence when disconnecting, disconnect the negative cable first. These engines produce enough direct current to keep the battery charged under normal operating conditions, but were not intended to be used as a battery charger.

WARNING: PERSONAL INJURY:

Lead acid batteries produce explosive hydrogen gas when charging. Keep sparks, flames, and burning cigarettes away from the battery. Ventilate the area when charging or using the battery in an enclosed space. Lead acid batteries contain sulfuric acid, which causes severe burns. If acid contacts eyes, skin, or clothing, flush well with water. For contact with the eyes, get immediate medical attention.

CAUTION:

Do **NOT** open or mutilate the battery. Released electrolyte is known to be harmful to the skin and eyes and to be very toxic.

A battery presents a risk of electrical shock and high short circuit current. The following precautions must be observed when working with batteries:

1. Remove watches, rings and other metal objects.
2. Use tools with insulated handles.
3. Check both the battery cable ends and the battery posts to be sure they are free of corrosion.
4. Always connect the battery positive first and then connect the battery negative cable. When removing the battery cables from the battery reverse the procedure, disconnect the negative cable first and then the positive cable.
5. Be sure all connections are tight and coat the terminals and cable end with dielectric grease.

WARNING:

The electrolyte is diluted sulfuric acid that is harmful to the skin and eyes. It is electrically conductive and corrosive. The following precautions must be always be taken.

1. Always wear full eye protection and protective clothing.
2. Where electrolyte contacts skin, wash off immediately with water.
3. If electrolyte contacts the eyes, flush thoroughly and immediately with water and seek immediate medical attention.
4. Spilled electrolyte is to be washed down with an acid neutralizing agent. A common practice is to use a solution of one pound of bicarbonate of soda (baking soda) to one gallon of water. The bicarbonate of soda solution is to be added until the evidence of reaction, foaming, has ceased. The resulting liquid is to be flushed with water and the area dried.

DANGER: EXPLOSIVE FIRE RISK

Never smoke when near batteries. Do not cause a flame or spark in the battery area. Always discharge static electricity from your body before touching batteries by first touching a ground metal surface.

SERVICING BATTERIES

Batteries used on these units may over time lose water. This is especially true if you are using a trickle charger to

maintain your battery. When refilling the battery with water use only distilled water. Tap water will shorten the service life of the battery.

Never fill the battery above the fill line. Overfilling above the upper level line may cause the electrolyte to overflow, resulting in corrosion to the engine or nearby parts. Immediately wash off any spilled electrolyte following the procedure above.

Note: always make sure that a new battery is fully charged before installing it on a generator set.

All connections must be clean and tight. Check the electrolyte (fluid) in the battery periodically to be sure it is above the plates. Never allow the battery to remain in a discharged condition.

BATTERY CHARGING

Units have a small flywheel charger built into the engine flywheel assembly for recharging the starting battery. This flywheel charger generates a small AC current that passes through a diode assembly to produce DC charging current of about 1 to 3 Amps. This circuit is not designed to be used as a battery charging circuit to recharge dead batteries.

CONTROL PANEL

The control panel can be installed on either side of the genend. Placement will be determined on the installation of the unit.

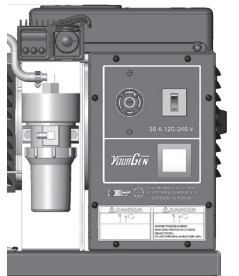

1. Snip off the zip ties around the wires that will be getting moved. Remove the front cover of the control panel. Locate the two bolts inside the panel that are securing the panel to the skid. Remove these two bolts. Make sure to keep track of all hardware being taken off and keep in an area where they won't get lost.



2. Remove the 4 screws around the top of the genend and remove the cover. There is a rubber grommet that secures the wires in place, gently remove it by pulling it down, keeping the wires through it.

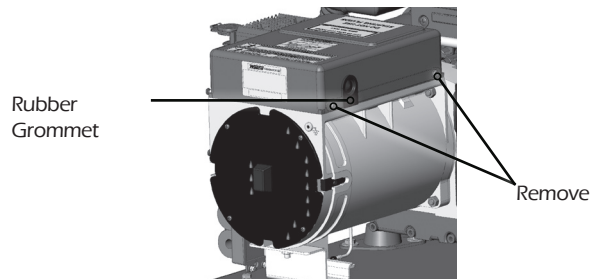

3. Place the panel on the other side of the generator (receptacle facing out). Secure the panel to the skid mount using the pre-installed rivet nuts.

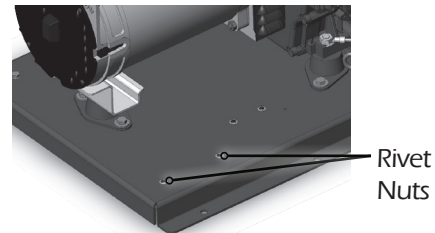

4. Replace the control cover. Push the rubber grommet with the wires through it, back onto the genend cover. Place the cover back on the genend with the grommet on the same side of the control panel. Secure the wires with new zip ties.

FUEL PUMP

Like the control panel, the fuel pump can also be placed on either side of the generator.

1. Snip the zip ties around wires/lines that will be moved. Detach the ground wires from the skid base (green wire) and in front of the engine (black wire). Locate the two bolts on the fuel pump mounting bracket.

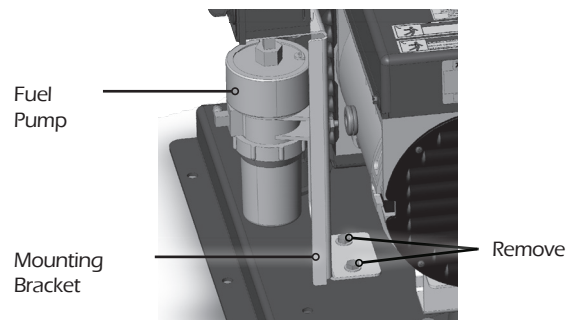

2. Carefully, to ensure diesel fuel does not leak, move the fuel pump to the other side of the unit. The fuel line will be longer than needed and will need to be shortened. Secure the fuel pump mounting bracket to the skid mount using the pre-installed rivet nuts.

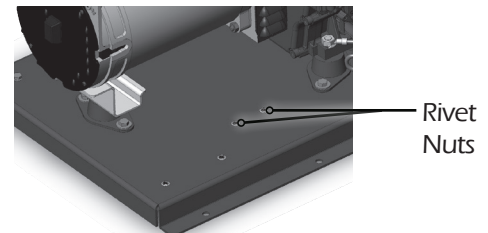

3. Reconnect the ground wires. The green wire connects to the skid base. There may already be a ground wire screwed down, add the green wire and re-secure the screw. The black, longer wire will connect to the front of the engine.

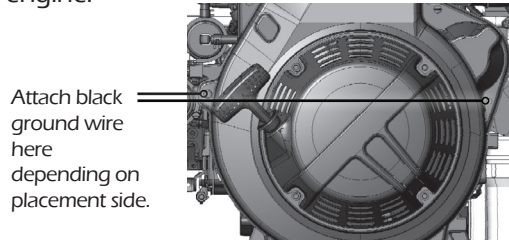

CONNECTING FUEL SUPPLY

Fuel Pump Specifications:

Voltage	12
PSI	9.0 to 11.5
Amps	1.6 average
Average Lift	6 feet

The fuel pump is self-priming and self-regulating.

Tank size, tank location, hose size, hose routing, and hot spots all play a role in a successful fuel tank installation. Preferred fuel installations use 1/4" hose that run straight to the engine with no drops or twists from an adequately sized fuel tank.

Connect a 1/4" fuel hose to the hose fitting located on the fuel pump. Use a hose clamp to secure the hose to the fitting.

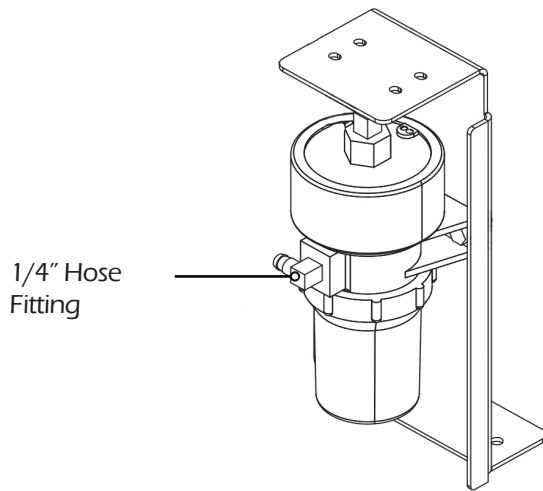

Connect fuel line to the fuel source.

A 1/4" fuel return hose will connect to the T-fitting located above the engine.

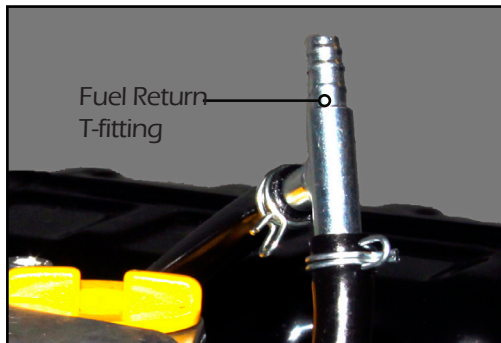

Secure the return hose with a hose clamp. Connect the return line to the fuel source.

INITIAL START UP

The throttle control on these generators is preset and locked to operate at 3600 RPM (nominal) with no load speed set at 3690 RPM. Only a trained service technician should be allowed to adjust this speed setting.

NOTICE: ENGINE START LOCKOUT

This unit will not start if it is low on oil. The lubricating oil level must be at the full mark before the engine will start and run. This engine will not start without a battery. The fuel shut-off solenoid requires 12V DC to operate.

BASIC OPERATION

If the engine is cold and stiff or if the battery is not fully charged, starting can be made easier by slowly hand cranking the engine through the compression stroke before pushing the starter switch. This permits the starter to gain momentum before the heavy load of the compression stroke occurs. This minimizes the drain on the battery and improves the possibility of starting under such adverse conditions. Always keep the battery charged, especially during cold weather operation.

1. Check oil level, refill as needed.
2. Make sure the fuel solenoid valve lever is in the down position. This lever is located under the key switch as pictured. The lever is located under the key switch as pictured.

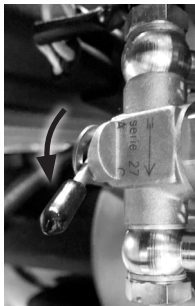

3. Turn key to 1st position (Ref A).

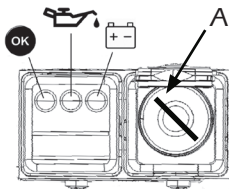

4. Turn key to the 2nd position - starting (Ref B).

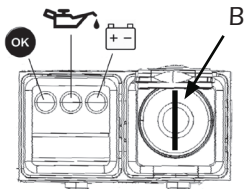

5. Return key to 1st position when engine is running (Ref A).

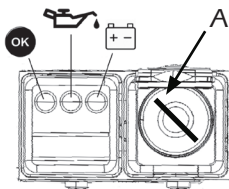

NOTE: While the engine is running, all warning lights should be off except the OK light.

STARTING HINTS

1. COLD WEATHER
Use the proper oil for the temperature expected.

CAUTION: EQUIPMENT DAMAGE

Never use ether or any other starting aides. Serious engine damage or personal injury may result from ignoring this simple warning.

2. HOT WEATHER
Use the proper oil for the temperature expected.

STOPPING

1. Move the key to the "OFF" position.



2. Make sure the fuel solenoid valve lever is in the down position. The lever is located under the key switch as pictured. The generator will not shutdown if this lever is in the up position.

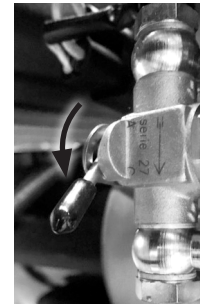

3. Before extended storage (over 30 days) certain precautions must be taken to ensure the fuel doesn't deteriorate and clog the fuel system.

NOTE: Running the engine to use up the fuel in the lines, fuel pumps and injectors will still leave a small amount of fuel in the system. It is best extended storage to treat the fuel before draining.

- A. While the engine is warm, drain the oil and refill with fresh oil.
- B. Clean dirt and chaff from cylinder, cylinder head fins, blower housing, screen, and muffler areas.
- C. Store in a clean and dry area.

CONNECTING THE LOADS

The engine-generator covered in this manual was designed for portable use. Do NOT operate indoors. The unit should be stored in a warm, dry location. Move the unit outdoors to a flat, dry location for use.

WARNING: PERSONAL DANGER:

Operating any engine driven generator without proper air flow can result in personal injury or death. DO NOT operate this unit inside a home or garage, near vents or windows, or anywhere carbon monoxide gas could accumulate.

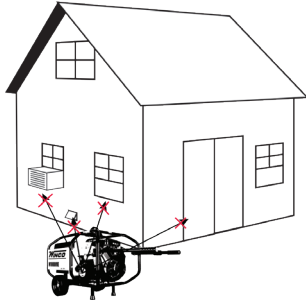

Failure to properly limit and balance the load applied to the generator will cause the generator to produce low voltage and may damage the engine generator set. It may also cause severe damage to the loads connected to the generator at the time. Improper loading of the generator set constitutes abuse and will not be covered by warranty.

A 30 Amp receptacle (NEMA L14-30) has been provided to allow the connection of loads to the generator. This receptacle is a full load receptacle protected by a 30 Amp hydraulic magnetic breaker. The breaker toggle switch is located on the control panel, located next to the receptacle.

Your individual loads must be protected by individual circuit breakers mounted in some type of distribution panel. This location will also be where you will install your neutral to ground bond. You must wire four separate wires from the generator (2-hot, 1-neutral, and 1-ground) to the distribution panel.

APPLYING THE LOADS

Allow the engine to warm up for two or three minutes before applying any load. This will allow the engine to reach normal operating temperature and oil to circulate throughout the engine. A short warm-up time will permit the engine to work more efficiently when the load is applied and will reduce the wear in the engine, extending its life. Receptacles have been provided to allow loads to be connected to the generator.

The loads should be added one at a time. If a large motor is being started: or multiple motors are being started, they should be started individually and the largest should be started first.

CAUTION: EQUIPMENT OVERLOAD

Keep the generator load within in the generator and receptacle nameplate rating. Overloading may cause damage to the generator and/or the loads.

Most electric tools and appliances will have the voltage and amperage requirements on their individual nameplates. When in doubt, consult the manufacturer or a local electrician. The nameplate amperage rating for electric motors can be misleading. See "Starting Electric Motors" in the Unit Capabilities.

This generator end is controlled by an AVR. The engine governor will automatically adjust itself to the load. No harm to the generator will result if it is operated with no load connected.

CAUTION: EQUIPMENT DAMAGE

Diesel engines should never be run for an extended period of time with a very light load or no load on them, it may do permanent damage to the engine if run under these conditions.

Proper utilization of the receptacles located on the control panel is necessary to prevent damage to either the receptacles or the generator. The generator is a limited source of electrical power, therefore, pay special attention to the receptacle and generator ratings. The nameplate rating can be obtained through a single receptacle as long as the receptacles amperage rating is not exceeded.

GROUNDING

Proper grounding of your generator is application dependent. Carefully evaluate your planned use of your generator to understand which grounding you require. If you are not sure what to do, contact a competent professional to assist you. The NFPA 70 250:34-35 are good technical references.

STANDARD PORTABLE GENERATOR

Your WINCO portable generator ships with a bonded neutral. You can safely use this generator without external grounding as long as all loads are powered through the receptacle panel.

VEHICLE-MOUNTED GENERATOR

Your WINCO portable generator ships with a bonded neutral. When mounted to a vehicle to safely distribute power it is necessary that the generator frame is bonded to the vehicle frame. The generator should only supply equipment that is cord and plug connected through receptacles mounted on the generator or the vehicle.

PERMANENTLY INSTALLED GENERATORS

This WINCO portable generator ships with a bonded neutral and overcurrent protection. NFPA 70 refers to this as a "separately derived system." When connecting it to a building a transfer switch specifically designed for GFCI and bonded neutral generators is required.

WIRING

Plug your tools such as drills, saws, blowers, sump pump, and other items to be powered directly into the generator receptacles. Before plugging in all the tools and cord sets, recheck the rating of the generator set. Be sure it can handle the intended load and is compatible with the voltage, phase, and current ratings. 'Hard wiring' this unit directly into a temporary construction site electrical system is **NOT A SIMPLE DO-IT-YOURSELF JOB**. For your safety, all wiring must be done by a qualified electrician and conform to the National Electric Code and comply with all state and local codes and regulations. Check with local authorities before proceeding.

WARNING: PERSONAL DANGER

A fully isolated, double pole double throw manual transfer switch must be installed any time a generator is being connected to an existing distribution system.

1. These engine-generator sets are designed for portable heavy duty commercial use. Receptacles are provided on the control panel to permit 120 and 240 Volt portable appliances and tools to be plugged directly into them. A 4-wire receptacle (two hot, one ground, and one neutral) has been provided on the control panel for use in temporary power applications requiring 120/240 Volt power.
2. If the generator set is connected to an existing distribution system, a fully isolated manual transfer switch must be installed. The transfer switch prevents damage to the generator and the other circuit components if main line power is restored while the generator is connected. Installing a transfer switch also permits the use of normal fusing.
3. Many homes and construction sites are wired for at least 60 to 100 Amp entrance service, much greater than the capacity of this portable generator. When installing the generator at these sites, a secondary emergency distribution panel may have to be installed. The emergency distribution panel must be installed by a licensed electrician according to all applicable codes. The electrician will move the critical circuits to be powered during the outage to the emergency panel. Keep in mind only a limited amount of amperage is available from the generator set. Some circuit breakers may still have to be turned off to prevent an overload on the generator during the initial start up. See the nameplate on your generator for the amperage \ capabilities of your unit.

CAUTION: EQUIPMENT DAMAGE

Failure to properly limit and balance the load applied to the generator will cause the generator to produce low voltage and may damage the engine generator set. It may also cause severe damage to the loads connected to the generator at that time. Improper loading of the generator set constitutes abuse and will not be covered by warranty.

YOURGEN

The WINCO YourGen meter allows you to see useful information about your generator from the front panel by displaying RPMs, Voltage, frequency, load, hours, and maintenance reminders. It also has the ability to display warnings if any parameter gets outside of normal operation range.



Cycle Button () -

During normal operation, the display will toggle through on fixed delay. If you want to see any specific item, you can press the cycle button to move it to that setting. Once the display is selected, the delay is approximately 5 seconds before it starts toggling. This button is also used to reset maintenance reminders.

RPM -

The meter will display the RPMs of the engine. This number is calculated based upon frequency and is not directly measured from the engine. The engine-generator must be run at the correct speed in order to produce the proper electrical voltage and frequency.

CAUTION: EQUIPMENT DAMAGE

The output voltage should be checked to ensure the generator is working properly prior to connecting a load to the generator. Failure to do so could result in damage to equipment plugged into the unit and possible injury to the individual.

Operating Speed

All engines have a tendency to slow down when a load is applied. When the electrical load is connected to the generator, the engine is more heavily loaded, and as a result, the speed drops slightly. This slight decrease in speed, together with the voltage drop within the generator itself, results in a slightly lower voltage when the generator is loaded to its full capacity than when running no load. The slight variation in speed also affects the frequency of the output current. This frequency variation has no appreciable effect in the operation of motors, lights, and most appliances. However, electronic equipment and clocks will be affected if correct RPM is not maintained. See Load vs. Output chart.

Although individual units and models vary slightly, the normal voltage and frequency of the engine-generator described in this manual are approximately as follows, under varying loads:

LOAD vs. OUTPUT			
Generator Load	Speed (RPM)	Frequency (Hz)	Voltage
None	3690	61.5	120V
Half	3600	60.0	120V
Full	3510	58.5	120V

The speed of the engine was carefully adjusted at the factory so that the generator produces the proper voltage and frequency. For normal usage, the speed setting should not be changed. If the generator is being run continuously on a very light load, it is often advisable to lower the operating speed slightly.

The engine will govern itself at full speed. Intentionally overriding the governor and operating the generator at low voltage may damage both the generator and any load connected to it. Running the engine at excessively high speeds results in high voltage, which may significantly shorten the life of light bulbs and appliances being used, as well as possibly damaging the engine.

CAUTION: EQUIPMENT DAMAGE

SPEED ADJUSTMENTS SHOULD ONLY BE MADE BY A QUALIFIED SERVICE TECH. Whenever making any speed adjustments, check the YourGen meter and be sure the voltage and speed are correct.

Output voltage should be checked periodically to ensure continued proper operation of the generating plant and appliances.

Hz -

This is the measured frequency of the generator set. See the table in the RPM section above for an explanation of voltage and frequency ranges under load.

V1 -

Output voltage of Line 1 (L1 on panel) to neutral. See the Load vs. Output table for an explanation of voltage and frequency ranges under load.

V2 -

Output voltage of Line 2 (L2 on panel) to neutral. See the Load vs. Output table for an explanation of voltage and frequency ranges under load.

V1-V2 -

Output voltage of Line 1 (L1) and Line 2 (L2). See the Load vs. Output table for an explanation of voltage and frequency ranges under load.

Hours -

This displays the total running hours of the generator set. When the generator is turned off, the hours will remain displayed. The display is run on a CR2032, ten-year battery. Once the unit is running, the battery connected to the unit will then supply the power to the YourGen meter.

Load Bars -

These bars indicate how much load is being used on Line 1 (L1) and Line 2 (L2).



 ■ = 1-25% ■ = 25-50% ■ = 50-75% ■ = 75-100%

It is good practice to monitor the YourGen Meter when applying load. This will ensure the generator is balanced.



Balanced



Unbalanced

120 Volt and 240 Volt receptacles are provided for connection to various loads.

The following diagram represents this 5,160 watt (rated output) generator. A & B represent the 120 volt output legs of this generator. Up to 2,580 watts at 120 volts (43 Amps) can be drawn from the receptacles attached to either A or B output legs. This generator is capable of producing 21.5 Amps of 240 volt current at C. Check the appliance or tool nameplates for the current and voltage to insure compatibility. Remember that power taken from C reduces the power available equally at both A and B and vice versa.

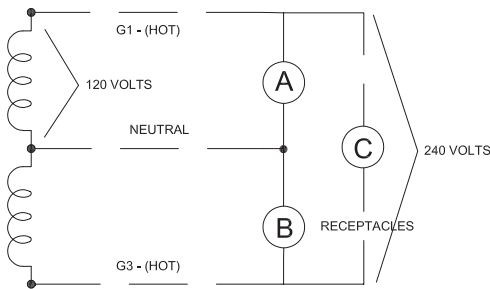

Change Oil Warning -

After the first 50 hours, the engine oil should be changed. The YourGen meter will light up the oil icon (🛢️) and the word 'change' will flash. Once the oil has been changed, press and hold the cycle button for approximately 5 seconds until the warning has been removed from the display to reset the warning. The meter will then remind you of oil changes on the appropriate schedule for your generator. It is important to remember that the engine manufacturer recommends changing the oil on a calendar schedule even if the total number of operational hours have not been reached. Certain operating environments may also require more frequent oil changes.

Alarms -

The display will start blinking and toggle to the first parameter that is out of specification. The panel will remain flashing until the fault condition returns to within the acceptable range, see following table.

	Acceptable Range
Frequency	57-63 Hz
Voltage	110VAC-130VAC
VAC1-VAC2	220VAC-260VAC

Battery -

When the unit is off, the YourGen meter will display the hours continuously using a coin cell back-up battery inside the meter. Once the unit is running, the meter will get power from the main unit battery.

Voltage 3.0V DC
 Battery Type CR2032
 Lifetime 10 Years

The battery has a 10 year lifetime, in the event you need to change the battery, follow these instructions:

1. The battery is located in the control box near potentially live AC terminals. To prevent electrocution while changing the battery disable the unit by disconnecting the main battery and then open the receptacle panel. Locate the backside of the YourGen meter. Gently pry the back plate off using the slot located on top.

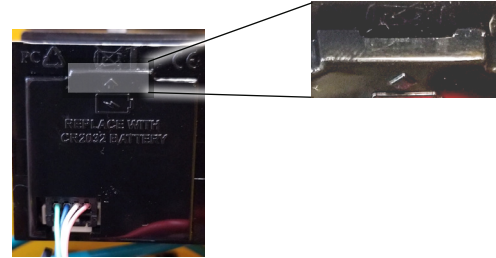

2. Once open, the battery will be located at the top. Using a needle nose plier, carefully pull out the battery.

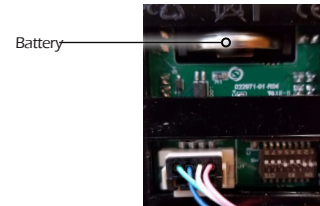

3. Replace the battery having the POSITIVE (+) side down. Ensure the battery is secured between the battery connections.



4. Replace the back plate of the meter and close the receptacle panel using the screws to secure it. Reconnect the unit's main battery.

ENGINE CARE

MAINTENANCE SCHEDULE

	Daily or Every 10 hrs	Every 250* hrs	Every 500** hrs
Check Oil	✓		
Check oil filter	✓		
Check dry air cleaner	✓		
Fuel tank cleaning			✓
Clean cooling fins			✓
Replace engine oil		✓	
Replace oil filter		✓	
Replace fuel filter			✓
Set and clean injectors			✓
Rocker arm adjustment			✓

* If engine use is infrequent; every year

** If engine use is infrequent; every 2 years

If you are using oil of a quality lower than the recommended one then you will have to replace it every 150 hours

If major engine service or repair is required, contact an authorized engine service center. The manufacturer of these engines has established an excellent world-wide engine service organization. Engine service is very likely available from a nearby authorized dealer or distributor.

CHANGING THE OIL

Change the oil after the first 50 hours of operation and yearly or 250 hours thereafter under normal operating conditions.

Outdoor temperatures determine the proper oil viscosity for the engines. Winco recommends our 5W-30 fully synthetic oil to give you excellent protection in cold temperatures while maintaining excellent performance in warmer weather.

- Change oil while the engine is still warm, the oil will flow more freely.
- Push in the yellow adapter slightly and turn to the left, unlocking the oil drain. Drain the oil into an approved container.

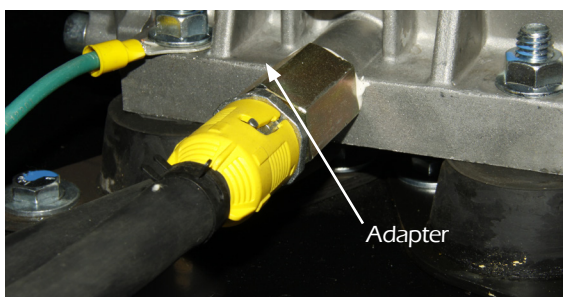

OPM-1257D

- Replace the adapter by pushing in and turning to the right to lock.
- Remove oil fill cap.

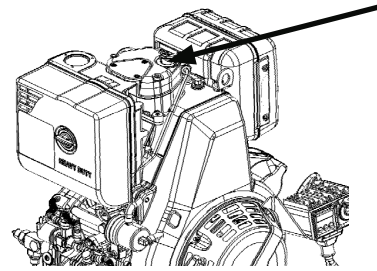

- Fill to correct level with oil. Reinstall cap.
- Remove the oil filter and dispose of it properly.



NOTE: This engine requires 41.6 oz. (1.3 qts) of oil if it is completely drained. Use caution when refilling the engine as some residual oil may have remained in the engine. Always use the dipstick when filling the engine with oil to prevent overfilling.

- Replace oil filter and filter plug.
- Start the engine and warm it up.
- After warming up the engine, recheck the oil level and refill as necessary to bring it to the proper level.

CHECKING THE OIL LEVEL

The oil level must always be checked before the engine is started. Take care to remove any dirt or debris from around the oil plug before removing. Be sure the oil level is maintained. Fill to the "FULL" mark on the dipstick.

AIR FILTER

Clean the filtering element with air blast. Air must be blown from inside to outside the cartridge at a distance of at least 6 inches from the paper. Lightly and repeatedly tap the element on a hard surface to eliminate all excess dirt.

WARNING: EQUIPMENT DAMAGE

Never start or run the engine with the air filter removed.

- Remove the cover.



B. Remove the wing nut.



C. Remove the filter element.



D. Check the rubber seal is undamaged.



- E. To loosen debris, gently tap the air filter on a hard surface. If the air filter is excessively dirty replace with a new filter. You can use pressurized air (not to exceed 30 psi) to clean the filter. Always blow the compressed air from inside to the outside.
- F. Clean the dirt from the inside of the air cleaner body and cover. Reinstall the filter in housing. Tighten the wing nut securely.
- G. Install and secure the cover.
- H. Remove and clean the pre-filter if clogged.

GENERATOR CARE

Proper care and maintenance of the generator is necessary to ensure a long trouble free life.

EXERCISING THE GENERATOR

The generator should be operated every three to four weeks. It should be operated for a period of time sufficient to warm the unit up and to dry out any moisture that has accumulated in the windings. If left, this moisture can cause corrosion in the winding. Frequent operation of the engine-generator set will also ensure that the set is operating properly should it be needed in an emergency.

GENERATOR MAINTENANCE

Any major generator service, including the installation or replacement of parts, should be performed only by a qualified electrical service technician. **USE ONLY FACTORY APPROVED REPAIR PARTS.**

- A. Bearing - The bearing used in these generators is a heavy duty, double sealed ball bearing. They require no maintenance or lubrication.
- B. Receptacles - Quality receptacles have been utilized. If a receptacle should become cracked or otherwise damaged, replace it. Using damaged or cracked receptacles can be both dangerous to the operator and destructive to the equipment.

CLEANING

Remove dirt and debris with a cloth or brush. DO NOT use high pressure spray to clean either the engine or the generator. The high pressure spray could contaminate the fuel system and the generator components.

1. Keep the air inlet screen on both the engine and generator free of any dirt or debris to ensure proper cooling. At least yearly, remove the blower housing on the engine and clean the chaff and dirt out of the engine cooling fins and fly wheel. Clean more often if necessary. Failure to keep these areas clean may cause overheating and permanent damage to the unit.
2. Periodically clean muffler area to remove all grass, dirt, and combustible debris to prevent a fire.
3. On engine mufflers equipped with spark arresters, the spark arrester must be removed every 50 hours for cleaning and inspection. Replace if damaged.

TROUBLESHOOTING

Problem	Possible Causes
Won't start	Low oil level Out of fuel Start switch in OFF position Fuel Valve turned off Plugged fuel filter Blown fuse in key switch Battery required to open solenoid
Voltage too low	Engine speed is too low Generator overloaded Defective stator Defective rotor (field) Defective AVR
Circuit breaker trips	Defective load Defective receptacle Excessive load GFCI type of load i.e. a building with bonded neutral
Voltage too high	Engine speed is too high
Generator overheating	Overloaded Insufficient ventilation
No output voltage	Short in load (disconnect) Tripped or defective circuit breaker Broken or loose wire Defective receptacle No residual magnetism (in generator) Defective stator Defective rotor (field) Shorted capacitor Shorted diodes on rotor GFCI receptacle tripped
Will not shutdown	Fuel solenoid valve lever is in up position

CONTROL PANEL WIRING DIAGRAM

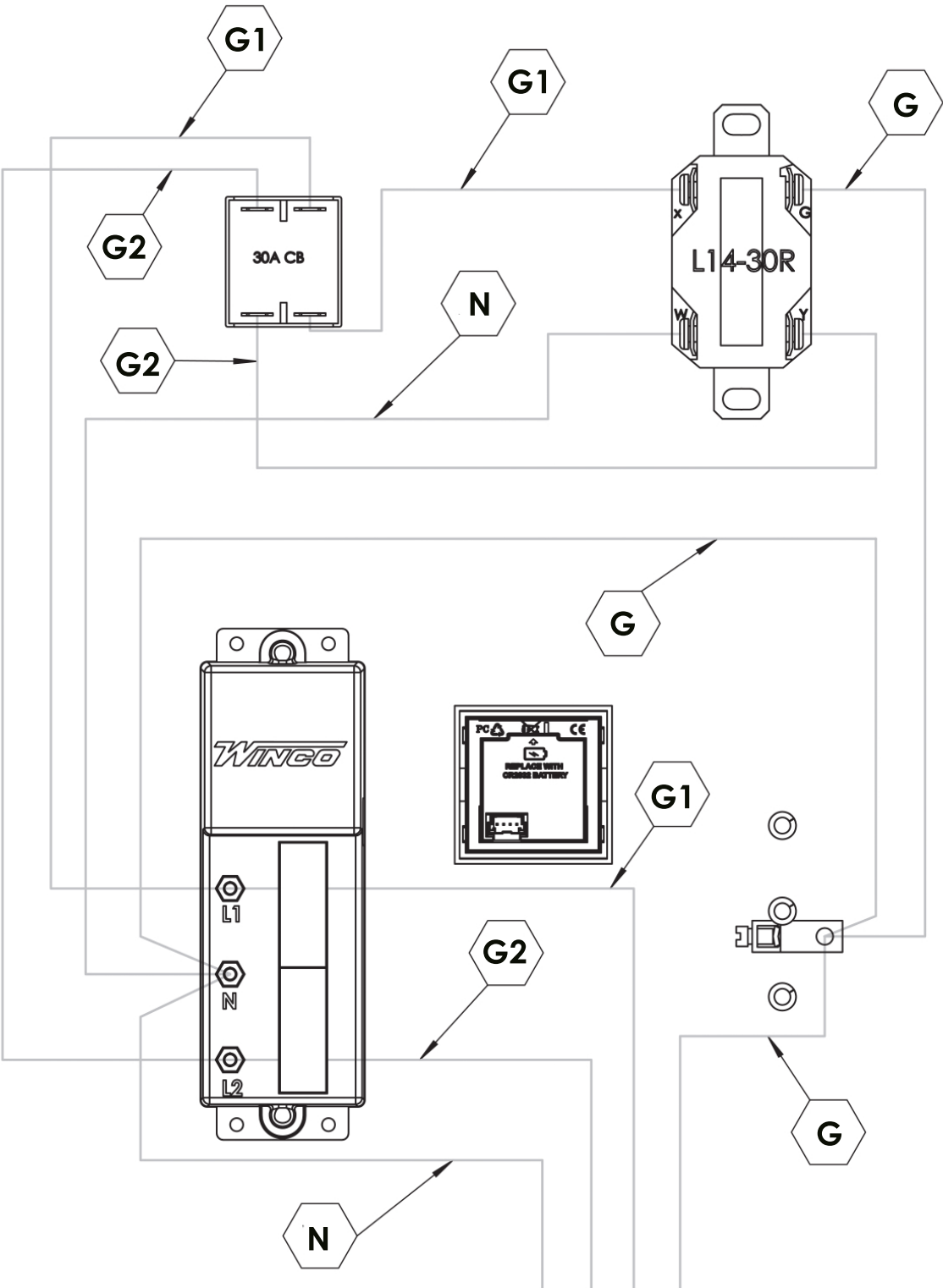

WINCO warrants to the original purchaser for 24 months that goods manufactured or supplied by it will be free from defects in workmanship and material, provided such goods are installed, operated and maintained in accordance with WINCO written instructions and applicable codes.

WINCO's sole liability, and Purchaser's sole remedy for a failure under this warranty, shall be limited to the repair of the product. At WINCO's option, material found to be defective in material or workmanship under normal use and service will be repaired or replaced. For warranty service, return the product within the warranty period, to your nearest WINCO Authorized Service Center or to WINCO in Le Center Minnesota.

Duration Consumer, Commercial and Rental

Parts & Labor: 24 Months

Parts Only: 24 Months

EXCLUSIONS:

- Normal maintenance consumables or labor.
- This warranty does not cover travel time, mileage or labor for removal or re-installation of WINCO product from its application.
- Normal wear and tear.
- Costs of rental equipment.
- WINCO does not warrant engines. Engines are covered exclusively by the warranties of their respective manufacturers.
- WINCO does not warrant component parts that are warranted by their respective manufacturers.
- WINCO does not warrant modifications or alterations which were not made by WINCO.
- WINCO does not warrant products which have been subjected to misuse and/or negligence or have been involved in an accident. Proof of proper maintenance must be furnished upon request.

THERE ARE NO EXPRESS WARRANTIES OTHER THAN THOSE DESCRIBED HEREIN. THERE ARE NO OTHER WARRANTIES, EXPRESSED OR IMPLIED, OR OTHERWISE CREATED, INCLUDING BUT NOT LIMITED TO WARRANTIES OF MERCHANTABILITY, OR WARRANTIES OF FITNESS FOR A PARTICULAR PURPOSE.

WINCO is liable for the repair or replacement of the product only and is not liable for incidental or consequential damages as permitted by your state. This warranty gives you specific legal rights which may vary from state to state.

CALIFORNIA EVAPORATIVE EMISSION CONTROL WARRANTY STATEMENT

YOUR WARRANTY RIGHTS AND OBLIGATIONS

The California Air Resources Board is pleased to explain the evaporative emission control system's warranty on your model 2020 generator. In California, new equipment that uses small off-road engines must be designed, built, and equipped to meet the State's stringent anti-smog standards. WINCO must warrant the evaporative emission control system on your generator for the period listed below provided there has been no abuse, neglect or improper maintenance of your equipment leading to the failure of the evaporative emission control system.

Your evaporative emission control system may include parts such as: carburetor, fuel tank, fuel cap, fuel lines (for liquid fuel and fuel vapors), fuel line fittings, fuel line clamps, carbon canisters, and carbon canister mounting brackets.

MANUFACTURER'S WARRANTY COVERAGE

The evaporative emission control system is warranted for two years. If any evaporative emission related parts on your equipment are defective, the parts will be repaired or replaced by WINCO.