

## FEATURES

### FPT C87 TE1D Engine

FPT Industrial (a division of Case/New Holland Industrial) is a leading manufacturer of engines for industrial applications backed by an extensive service network.

### Deep Sea 7310 MKII Controller

Digital controller providing immediate performance information and safety shutdowns.

### Stamford Generator End

Alternators built to produce clean power for industrial applications.

### Powder Coat Paint

Incredibly durable and long lasting finish.

### Block Heater

In-line Kim Hotstart, 120V, block heater with thermostat.

### Battery Charger

DSE 10 Amp charger standard.

### UL2200 Listed

A safety standard for the design, construction, and performance of stationary generators.

### 100% Load Tested

We load test every generator before it leaves our facility.

## WINPOWER® INDUSTRIAL DIESEL SERIES



Shown with optional enclosure

## OPTIONAL ACCESSORIES

### Sub-Base Fuel Tank

UL142 double wall steel fuel tank with stub up area allows for a clean installation with minimal footprint.

### WEBNET

Control your generator from your smart phone or computer.

### DOT Trailer

DOT approved trailer with integrated single wall fuel tank.

### Enclosure

14 gauge galvaneal steel with internal baffling and 1" foam for sound attenuation and weather protection.

### Battery Charger

A 10 Amp charger is standard with the possibility to upgrade 10 Amp NFPA compliant charger.

### BCI 4D 1200 CCA Battery

Interstate BCI 4D 1200 CCA. Quantity of 2 required.

## GENERATOR SET

OUTPUT	WATTS	KVA	AMPS	CB
				AMPS
120/240V 1-PH, 1.0 PF	N/A	N/A	N/A	N/A
120/208V 3-PH, 0.8 PF	250,000	312	867	900
120/240V 3-PH, 0.8 PF	250,000	312	752	800
277/480V 3-PH, 0.8 PF	250,000	312	376	400
SOUND DATA <sup>(1)</sup>				78
CERTIFICATION			UL2200 LISTED	

NOTE: (1) Measurement is in db(a). Tested at 7 meters (23ft) with housing.

## ALTERNATOR

RATING	(125/40°C) STANDBY
VOLTAGE REGULATION	+/- 1.5%
TOTAL HARMONIC DISTORTION	< 5%
TYPE	4 POLE REVOLVING FIELD
BRUSHLESS	YES
GENERATOR SPEED	1800 RPM
VOLTAGE CONTROL	MX341 PMG EXCITATION
ROTOR	2/3 PITCH
WINDINGS	100% COPPER
TELEPHONE INTERFERENCE	< 2.0%
EFFICIENCY PEAK	~ 93.5%
COUPLING	FLEXIBLE DISC
SINGLE PHASE	4 LEADS
3 PHASE	12 LEADS
BEARINGS	1 MAINTENANCE FREE
INSULATION	CLASS H
GENERATOR WARRANTY <sup>(1)</sup>	1 YR/1000 HRS

NOTES: (1) Standby only. Prime warranty 12 months/unlimited hrs. For more generator warranty information contact your local WINCO dealer.

## DERATING FACTORS

TEMPERATURE > 104°F	3% PER 10°F
ALTITUDE	3% EVERY 300M AFTER 1000M
PRIME POWER	20%
MAX OPERATING TEMP	122°F/50°C

## BATTERY

DC SYSTEM VOLTAGE	24V
BATTERY CHARGER	10 AMP
BATTERY RACK/CABLE	INCLUDED
REQUIRED BATTERY <sup>(1)</sup>	2 - GROUP 4D 1200 CCA

Notes: (1) Batteries not included

## ENGINE

BRAND	FPT
MODEL	C87 TE1D
SPEED	1800 RPM
EPA	TIER III
TYPE	DIESEL
GROSS HP (STANDBY)	391
BORE x STROKE	4.52" x 4.9"
GOVERNOR	ELECTRONIC
CYLINDERS	6
TOTAL DISPLACEMENT	8.7 L
ASPIRATION	TURBOCHARGED
EXHAUST OUTLET <sup>(1)</sup>	5"
ALTERNATOR	90 AMPS
OIL & FILTER REPLACEMENT	600 HRS
RECOMMENDED OIL <sup>(2)</sup>	10W 30
OIL CAPACITY	29.6 QT
FLYWHEEL (TEETH 125)	14"
DISCHARGE CURRENT (EN 50342)	1200 A
COLD STARTING	
W/O PREHEATING	14°F (-10°C)
W/ PREHEATING	-13°F (-25°C)
ENGINE WARRANTY <sup>(3)</sup>	5 YRS/2000 HRS

NOTES: (1) Muffler ships loose. (2) This oil is recommended for most applications. See Operator's Manual for more details on the appropriate oil type for your needs.

(3) Standby, for more engine warranty information contact your local FPT dealer.

## BLOCK HEATER

VOLTS	120
WATTS	2.250
THERMOSTAT	
ON	80°F
OFF	100°F

## TANK OPTIONS

560 GALLON UL142	144" x 59.2" x 24"
690 GALLON UL142	144" x 59.2" x 29"
845 GALLON UL142	144" x 59.2" x 35"

## FUEL

FUEL TYPE	DIESEL
FUEL CONSUMPTION	
100% LOAD	16.98 GAL/HR
50% LOAD	10.25 GAL/HR

## OPTIONAL TRAILER W/ 500 GAL FUEL TANK

WEIGHT	3,200 lbs
AXLES	TRIPLE
GVWR	18,000 lbs
DIMENSIONS	250" x 94" x 37"

## DSE 7310 MKII CONTROLLER

### ENGINE DISPLAY

ENGINE RPM	YES
LOW OIL PRESSURE	YES
HIGH COOLANT TEMP	YES
LOW COOLANT	OPTIONAL
LOW OIL TEMP	OPTIONAL
OVER/UNDER SPEED	YES
OVER CRANK	YES
CHARGING ALT FAILURE	YES
CAN ECU SHUTDOWN	YES

### GENSET DISPLAY

VOLTAGE (L-N & L-L)	YES
OVER/UNDER VOLTAGE	YES
FREQUENCY	YES
OVER/UNDER FREQUENCY	YES
AMP DISPLAY/SHUTDOWN	YES
PHASE IMBALANCE	DISABLED
KW, KVA, KVAR, PF DISPLAY	YES
KWH, KVAH, KVARH, DISPLAY	YES
GENERATOR PHASE SEQUENCE	OPTIONAL
EARTH CURRENT	OPTIONAL

## SHIPPING

DIMENSIONS OPEN	144" x 59.2" x 64"
NET WEIGHT OPEN	6,300 LBS
DIMENSIONS ENCLOSED	180.74" x 59.2" x 83.77"
NET WEIGHT ENCLOSED	8,740 LBS
FREIGHT CLASS	70

### ADDITIONAL DISPLAYS/PROTECTIONS

EMERGENCY STOP	YES
FUEL LEAK/SENDER FAILURE	YES
BATTERY OVER/UNDER VOLTAGE	YES
BATTERY CHARGER FAILURE	OPTIONAL

### COMMUNICATIONS

USB CONNECTABLE	YES
RS232/RS485	YES
NFPA ANNUNCIATOR	10XDSE 2548 OPTIONAL
REMOTE DISPLAY PANEL	3XDSE 2510 OPTIONAL
DSE850 WEBNET	OPTIONAL

### ADDITIONAL FEATURES

AUDIBLE ALARM	YES
ENGINE EXERCISER	YES
MAINTENANCE INTERVAL TIMER	OPTIONAL
LOAD SHEDDING/ DUMMY	OPTIONAL
CONFIGURABLE INPUTS	9-24 W/DSE 2130 OPTIONAL
CONFIGURABLE OUTPUTS	6-80 W/DSE 2751 OPTIONAL
EVENT LOG	YES
ALTERNATIVE CONFIGURATIONS	3
UL/CSA LISTED	YES



DSE 7310 MKII

## OPEN SKID

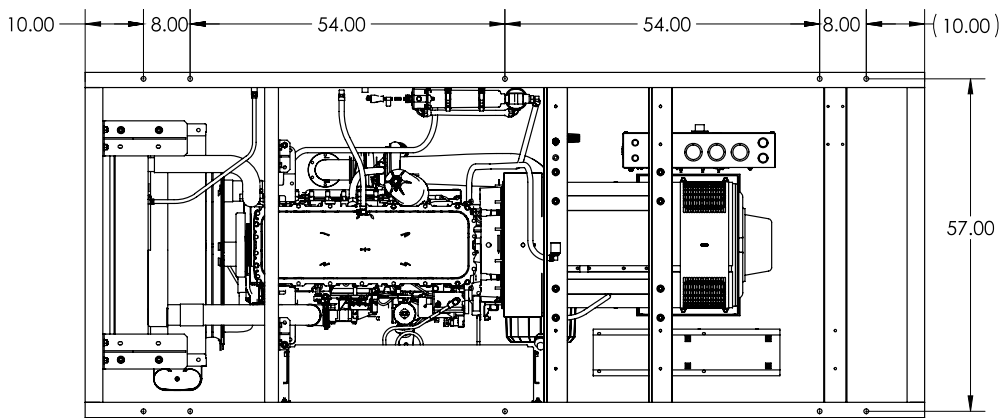
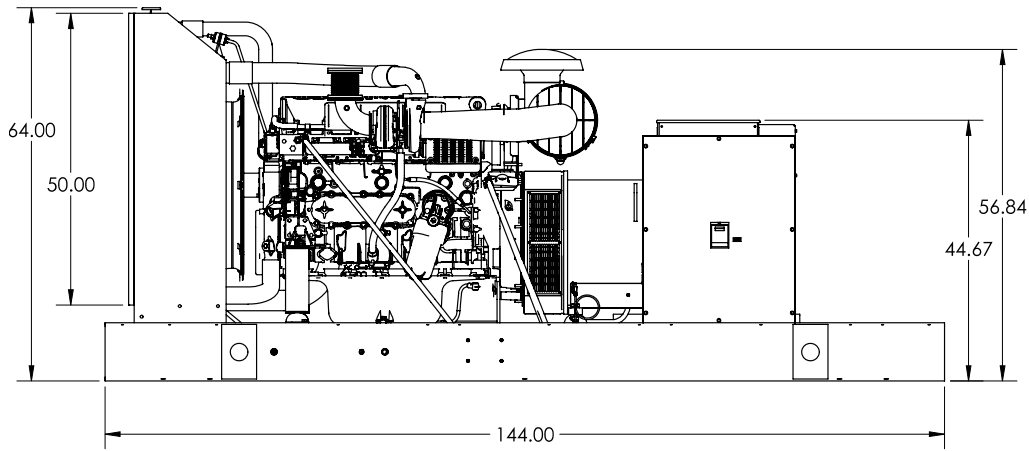

BOTTOM VIEW

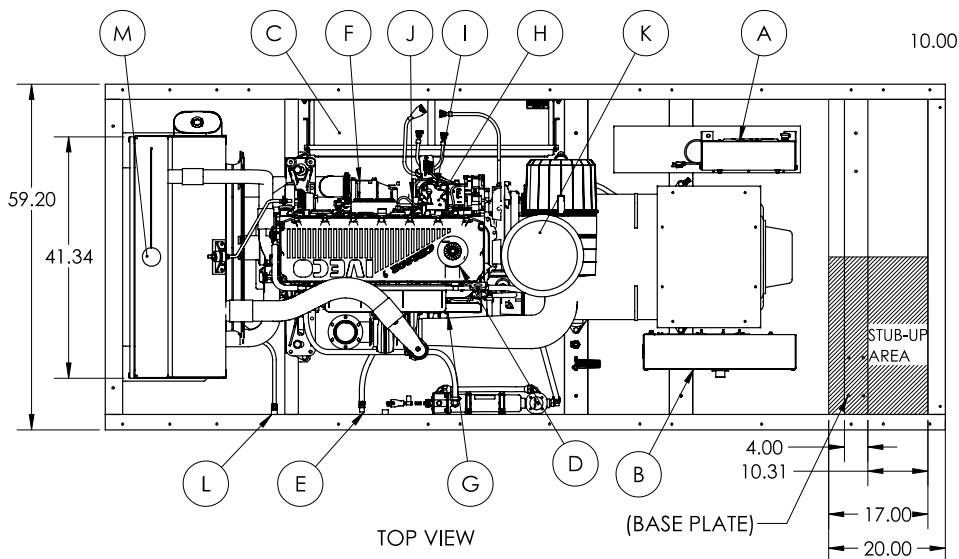

TOP VIEW

### Key Components

Key Components	
A	ENGINE CONTROL
B	MAIN LINE CIRCUIT BREAKER
C	START BATTERY
D	OIL FILL
E	OIL DRAIN
F	OIL DIPSTICK
G	OIL FILTER
H	FUEL FILTER
I	FUEL IN
J	FUEL RETURN
K	AIR FILTER
L	COOLANT DRAIN
M	COOLANT FILL

## ENCLOSED

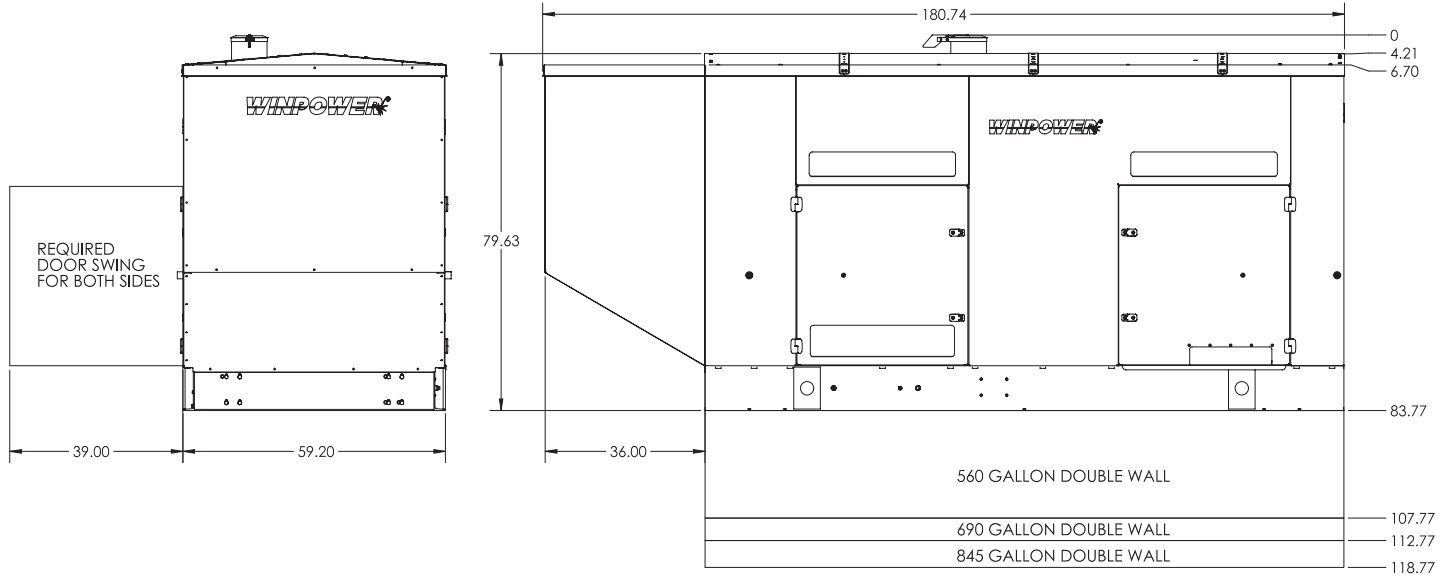

## TRAILER

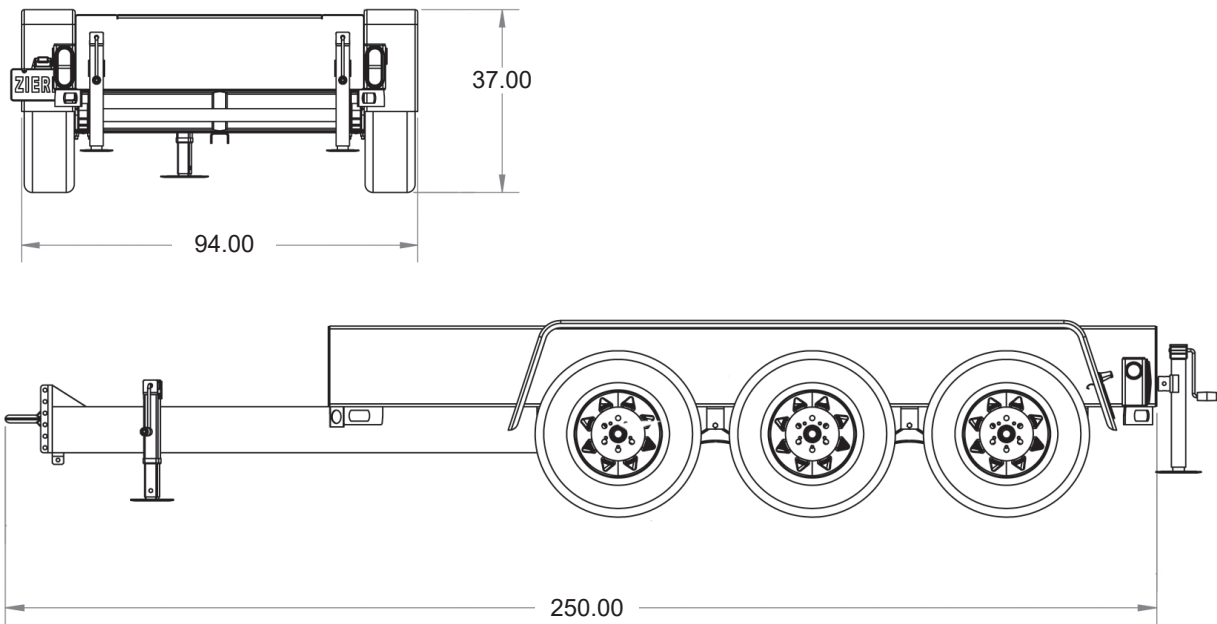

Specifications are subject to change without notice.