



Owner's Manual

Automatic Transfer Switch

*100 - 200 Amp, Service Entrance and Non-Service Entrance with
Surge Protection Device (SPD) (Where Applicable)*

Register your Generac product at:
WWW.REGISTER.GENERAC.COM
1-888-9ACTIVATE
(1-888-922-8482)

SAVE THIS MANUAL FOR FUTURE REFERENCE

Model:	
Serial:	
Date Purchased:	

Model Number

Non-Service Entrance (No Surge Protection Device)

G0099300

G0099350

Service Entrance Rated with

Utility Service Circuit Breaker (No Surge Protection Device)

G0099290

G0099320

G0099340

Service Entrance Rated with Utility Service Circuit Breaker & Surge Protection Device

G0099280**

G0099310

G0099330

**A0005902810 - Assembly number for G0099280 when bundled with generator

 **CALIFORNIA WARNING**

This product can expose you to chemicals including cadmium, a carcinogen and reproductive toxicant, which are known to the State of California to cause cancer and birth defects or other reproductive harm.

For more information, go to:
www.p65warnings.ca.gov

(W000810)

Table of Contents

Section 1: Safety

Introduction.....	5
Read This Manual Thoroughly	5
Safety Rules	5
Electrical Hazards	6
General Hazards	7

Section 2: General Information

Introduction.....	9
Unpacking.....	9
Non-Generac Parts and Equipment	9
Contents in Loose Parts Bag.....	9
Equipment Description	9
Transfer Switch Mechanism	9
Transfer Switch Mechanism.....	9
Utility Service Circuit Breaker (if equipped)	10
Transfer Switch Data Decal.....	10
Transfer Switch Enclosure	11
Safe Use of Transfer Switch.....	11
Load Management Options.....	11
Surge Protection Device	11
Equipment Description	11
Specifications	11
Auxiliary Contacts.....	11

Section 3: Installation

Introduction to Installation	13
Mounting.....	13
Mounting.....	13
Mounting with Mounting Bracket Cleat.....	13
Mounting without Mounting Bracket Cleat	14
Open Enclosure.....	14
Connecting Power Source and Generator	
Power Supply	15
Service Entrance Rated Models	15
Non-Service Entrance Rated Models.....	16
Connecting Start Circuit Wires	17
Typical Fuse Control Module Connections	18
Fault Current Label.....	19

Section 4: Operation

Functional Tests and Adjustments	21
--	----

Manual Operation.....	21
Manual Transfer to Utility Source Side	22
Manual Transfer to Generator Source Side	22
Voltage Checks	22
Utility Voltage Checks.....	22
Generator Voltage Checks.....	23
Generator Tests Under Load.....	23
Checking Automatic Operation	23
Surge Protection Device Operation (Select Models Only)	24
Installation Summary.....	24
Shutting Generator Down While Under Load or During a Utility Outage	24
Testing a Load Manager.....	25
FCM Fuse Service.....	25

Section 5: Drawings and Diagrams

Installation Drawing—100A/150A/200A Install with Cleat.....	27
Installation Drawing—100A/150A/200A Install Without Cleat.....	28
Installation Drawing—Liquid Cooled Generator	29
Installation Drawing—Liquid-Cooled Generator	30
Installation Drawing—Air-Cooled Generator SE and Non-SE Rated ATS	31
Installation Drawing—Air-Cooled Generator SE and Non-SE Rated ATS	32

This page intentionally left blank.

Section 1: Safety

Introduction

Thank you for purchasing a Generac Power Systems Inc. product. This unit has been designed to provide high performance, efficient operation, and years of use when maintained properly. This transfer switch is listed with ETL under the UL1008 standard.

Read This Manual Thoroughly



Consult Manual. Read and understand manual completely before using product. Failure to completely understand manual and product could result in death or serious injury. (W000100)

If any section of this manual is not understood, contact the nearest Independent Authorized Service Dealer (IASD) or Generac Customer Service at 1-888-436-3722 (1-888-GENERAC), or visit www.generac.com for starting, operating, and servicing procedures. The owner is responsible for proper maintenance and safe use of the unit.

SAVE THESE INSTRUCTIONS for future reference. This manual contains important instructions that must be followed during placement, operation, and maintenance of the unit and its components. Always supply this manual to any individual that will use this unit, and instruct them on how to correctly start, operate, and stop the unit in case of emergency.

Safety Rules

The manufacturer cannot anticipate every possible circumstance that might involve a hazard. The alerts in this manual, and on tags and decals affixed to the unit, are not all inclusive. If using a procedure, work method, or operating technique that the manufacturer does not specifically recommend, verify that it is safe for others and does not render the equipment unsafe.

Throughout this publication, and on tags and decals affixed to the unit, DANGER, WARNING, CAUTION, and NOTE blocks are used to alert personnel to special instructions about a particular operation that may be hazardous if performed incorrectly or carelessly. Observe them carefully. Alert definitions are as follows:



Indicates a hazardous situation which, if not avoided, will result in death or serious injury.

(D000001)



Indicates a hazardous situation which, if not avoided, could result in death or serious injury.

(W000002)



Indicates a hazardous situation which, if not avoided, could result in minor or moderate injury.

(C000003)

NOTE: Notes contain additional information important to a procedure and will be found within the regular text of this manual.

These safety alerts cannot eliminate the hazards that they indicate. Common sense and strict compliance with the special instructions while performing the action or service are essential to preventing accidents.

Electrical Hazards



DANGER

Electrocution. High voltage is present at transfer switch and terminals. Contact with live terminals will result in death or serious injury.

(D000129)



DANGER

Electrocution. Water contact with a power source, if not avoided, will result in death or serious injury.

(D000104)



DANGER

Electrocution. In the event of electrical accident, immediately shut power OFF. Use non-conductive implements to free victim from live conductor. Apply first aid and get medical help. Failure to do so will result in death or serious injury.

(D000145)



DANGER

Electrical backfeed. Use only approved switchgear to isolate generator from the normal power source. Failure to do so will result in death, serious injury, and equipment damage.

(D000237)



DANGER

Electrocution, equipment and property damage. Handle transfer switches carefully when installing. Never install a damaged transfer switch. Doing so could result in death or serious injury, equipment and property damage.

(D000195)



DANGER

Electrocution. Turn utility supply OFF before working on utility connections of the transfer switch. Failure to do so will result in death or serious injury.

(D000123)



DANGER

Electrocution. Do not disable or modify the connection box door safety switch. Doing so will result in death or serious injury.

(D000157)

DANGER

Automatic start-up. Disconnect utility power and render unit inoperable before working on unit. Failure to do so will result in death or serious injury.

(D000191)

DANGER

Equipment Malfunction. Installing a dirty or damaged transfer switch will cause equipment malfunction and will result in death or serious injury.

(D000119)

WARNING

Electric Shock. Only a trained and licensed electrician should perform wiring and connections to unit. Failure to follow proper installation requirements could result in death, serious injury, and equipment or property damage.

(W000155)



WARNING

Electrocution. Refer to NFPA 70E for PPE and safety equipment before work.

(W000221)

CAUTION

Equipment damage. Verify all conductors are tightened to the factory specified torque value. Failure to do so could result in damage to the switch base.

(C000120)

CAUTION

Equipment damage. Perform functional tests in the exact order they are presented in the manual. Failure to do so could result in equipment damage.

(C000121)

CAUTION

Equipment damage. Verify that voltage and current are within specification before energizing this equipment. Exceeding rated voltage and current will damage the auxiliary contacts.

(C000134)

General Hazards



⚠ DANGER

Electrical backfeed. Use only approved switchgear to isolate generator from the normal power source. Failure to do so will result in death, serious injury, and equipment damage.

(D000237)



⚠ DANGER

Electrocution. High voltage is present at transfer switch and terminals. Contact with live terminals will result in death or serious injury.

(D000129)



⚠ DANGER

Electrocution. Turn utility supply OFF before working on utility connections of the transfer switch. Failure to do so will result in death or serious injury.

(D000123)



⚠ DANGER

Electrocution. Water contact with a power source, if not avoided, will result in death or serious injury.

(D000104)



⚠ DANGER

Electrocution. Do not wear jewelry while working on this equipment. Doing so will result in death or serious injury.

(D000188)



⚠ DANGER

Electrocution. Only authorized personnel should access transfer switch interior. Transfer switch doors should be kept closed and locked. Failure to do so will result in death or serious injury.

(D000213)

⚠ DANGER

Automatic start-up. Disconnect utility power and render unit inoperable before working on unit. Failure to do so will result in death or serious injury.

(D000191)



⚠ WARNING

Loss of life. This product is not intended to be used in a critical life support application. Failure to adhere to this warning could result in death or serious injury.

(W000209)

⚠ WARNING

Equipment damage. This unit is not intended for use as a prime power source. It is intended for use as an intermediate power supply in the event of temporary power outage only. Doing so could result in death, serious injury, and equipment damage.

(W000247)



⚠ WARNING

Hearing loss. Hearing protection is recommended when transferring load. Failure to wear hearing protection could result in permanent hearing loss.

(W000766)

- Competent, qualified personnel should install, operate and service this equipment. Adhere strictly to local, state and national electrical and building codes. When using this equipment, comply with regulations established by the National Electrical Code (NEC), CSA Standard; the Occupational Safety and Health Administration (OSHA), or the local agency for workplace health and safety.
- If working on this equipment while standing on metal or concrete, place insulative mats over a dry wood platform. Work on this equipment only while standing on such insulative mats.
- Never work on this equipment while physically or mentally fatigued.
- Any voltage measurements should be performed with a meter that meets UL3111 safety standards, and meets or exceeds overvoltage class CAT III.

This page intentionally left blank.

Section 2: General Information

Introduction

Thank you for purchasing a Generac transfer switch. This manual has been prepared especially for the purpose of familiarizing personnel with the design, application, installation, operation and servicing of the applicable equipment. Read this manual carefully and comply with all instructions. This will help to prevent accidents or damage to equipment that might otherwise be caused by carelessness, incorrect application, or improper procedures.

Every effort has been expended to make sure that the contents of this manual are both accurate and current. The manufacturer, however, reserves the right to change, alter or otherwise improve the product or manual at any time without prior notice.

Unpacking

Carefully unpack the transfer switch. Inspect closely for any damage that might have occurred during shipment. The purchaser must file with the carrier any claims for loss or damage incurred while in transit.

Check that all packing material is completely removed from the switch prior to installation.

Non-Generac Parts and Equipment

Generac products obtain listings and certifications through an evaluation of the original design and configuration of the product. Any modification to this product, including the incorporation of non-Generac parts or equipment, may void this product's listing or certification. Damage or failures caused by any modification to the product are not covered by the product's warranty. See limited warranty for more information.

Contents in Loose Parts Bag

- Owner's manual
- Warranty statement
- Manual operating handle
- Fault current label
- Clear decal for fault current label
- Enclosure mounting cleat

Equipment Description

This automatic transfer switch is used for transferring electrical load from a utility (normal) power source to a generator (standby) power source. Transfer of electrical

loads occurs automatically when the utility power source has failed or is substantially reduced and the generator source voltage and frequency have reached an acceptable level. The transfer switch prevents electrical feedback between two different power sources (such as the utility and generator sources) and, for that reason, codes require it in all standby electric system installations.

The transfer switch consists of a transfer mechanism, utility service disconnect circuit breaker (if equipped), and a fused control module incorporating fuses and terminal blocks for transfer switch connections.

Transfer Switch Mechanism

Transfer Switch Mechanism

See [Figure 2-1](#) and [Figure 2-2](#). This switch is used with a single-phase system when the single-phase neutral line is to be connected to a neutral lug and is not to be switched.

Solderless, screw-type terminal lugs are standard.

The conductor size range is as follows:

Switch Rating	Wire Range	Conductor Tightening Torque
100A	#12-1/0 AWG (Cu/Al)	50 in-lbs (5.6 Nm)
150/200A	#6-250 MCM (Cu/Al)	275 in-lbs (31 Nm)

This transfer switch is suitable for control of motors, electric discharge lamps, tungsten filament and electric heating equipment where the sum of motor full load ampere ratings and the ampere ratings of other loads do not exceed the ampere rating of the switch and the tungsten load does not exceed 30 percent of the switch rating.

This UL listed transfer switch is for use in optional standby systems only (NEC article 702).

A 100A rated switch is suitable for use on circuits capable of delivering not more than 10,000 RMS symmetrical amperes, 250 VAC maximum, when protected by a 100A maximum circuit breaker (Siemens types QP or BQ) or 150A maximum circuit breaker (Square D Q2, Westinghouse CA-CAH, General Electric TQ2 and Siemens QJ2).

A 200A rated switch is suitable for use on a circuit capable of 22,000 RMS symmetrical amperes, 240 VAC when protected by a circuit breaker without an adjustable short time response or by fuses.

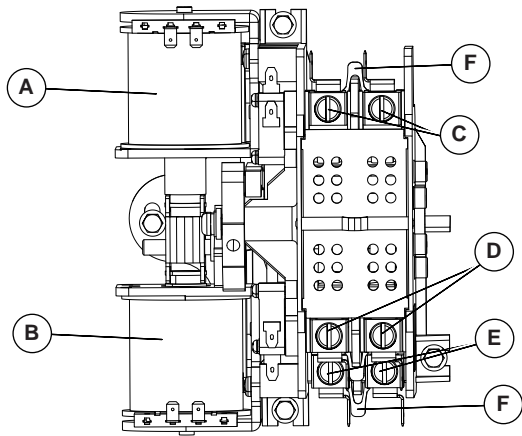

00047540

Figure 2-1. Typical Single-Phase ATS Transfer Mechanism (100A)

A	Utility Closing Coil
B	Generator Closing Coil
C	Utility Lugs (N1 & N2)
D	Generator Lugs (E1 & E2)
E	Load Lugs (T1 & T2)
F	Retention Clips (100A only)

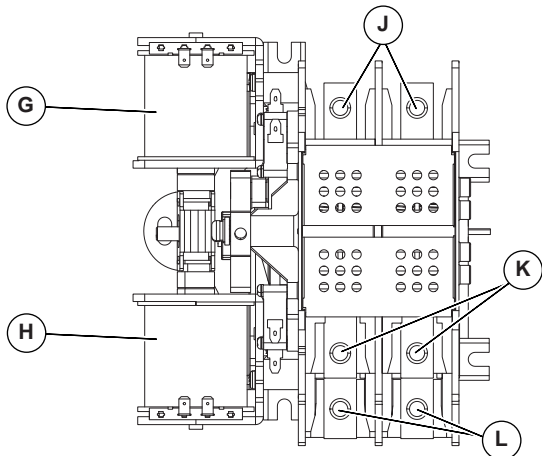

00047539

Figure 2-2. Typical Single-Phase ATS Transfer Mechanism (200A)

G	Utility Closing Coil
H	Generator Closing Coil
J	Utility Lugs (N1 & N2)
K	Generator Lugs (E1 & E2)
L	Load Lugs (T1 & T2)

Utility Service Circuit Breaker (if equipped)

The utility service and generator disconnect circuit breakers for 100 amp models are:

- Type BQ, 2-pole
- 10,000 A/C
- 120/240VAC, 100A
- 50/60 Hertz
- Wire range: #1 - #8 AWG (Cu/Al)
- The conductor tightening torque is 50 **in-lbs** (5.6 Nm)

The utility service circuit breakers for 150/200 amp models are:

- Type 225AF, 2-pole
- 22,000 A/C
- 120/240VAC, 150A/200A
- 50/60 Hertz
- Wire range:
 - Line: 300 MCM - 6 STR (Cu/Al)
 - Load - ATS: 250 MCM - 6 STR (Cu/Al)
- The conductor tightening torque is:
 - Line: 375 **in-lbs** (42.4 Nm)
 - Load - ATS: 275 **in-lbs** (31 Nm)

The utility service circuit breakers for Siemens 150/200 amp models are:

- Siemens, Type QN, 2-pole
- 10,000 A/C
- 120/240VAC, 150A/200A
- 50/60 Hertz
- Wire range:
 - Line: 300 MCM - 1 STR (Cu/Al)
 - Load - ATS: 250 MCM - 6 STR (Cu/Al)
- The conductor tightening torque is:
 - Line: 250 **in-lbs** (28.2 Nm)
 - Load - ATS: 275 **in-lbs** (31 Nm)

Transfer Switch Data Decal

A data decal is permanently affixed to the transfer switch enclosure. Use this transfer switch only with the specific limits shown on the data decal and on other decals and labels that may be affixed to the switch. This will prevent damage to equipment and property.

When requesting information or ordering parts for this equipment, make sure to include all information from the data decal.

For future reference, record the Model and Serial numbers in the space provided on the inside front cover of this manual.

Transfer Switch Enclosure

The standard switch enclosure is a National Electrical Manufacturer's Association (NEMA) and UL 3R type. UL and NEMA 3R (indoor/outdoor rated) type enclosures primarily provide a degree of protection against falling rain and sleet; are undamaged by the formation of ice on the enclosure.

Safe Use of Transfer Switch



⚠ WARNING

Consult Manual. Read and understand manual completely before using product. Failure to completely understand manual and product could result in death or serious injury. (W000100)

Before installing, operating or servicing this equipment, read the [Safety Rules](#) carefully. Comply strictly with all [Safety Rules](#) to prevent accidents and/or damage to the equipment. The manufacturer recommends that a copy of the [Safety Rules](#) be posted near the transfer switch. Also, be sure to read all instructions and information found on tags, labels and decals affixed to the equipment.

Three publications that outline the safe use of transfer switches are the following:

- NFPA 70; National Electrical Code
- UL 1008; STANDARD FOR SAFETY-AUTOMATIC TRANSFER SWITCHES
- UL 67; Panelboards Marking and Application Guide

NOTE: It is essential to use the latest version of any standard to ensure correct and current information.

Load Management Options

Optional Load management systems are designed to work with the automatic transfer switch to prevent a generator from being overloaded by large appliance loads. Contact the nearest IASD for more information to determine if a load management device is required for your system configuration.

Surge Protection Device

Equipment Description

The included Surge Protection Device (SPD) is designed to be installed on service entrance, branch panels, and/or individual equipment disconnects, and functions to protect sensitive electronic equipment from damaging voltage transients. The connecting wires do not carry supply current. Instead, they carry only short-duration currents associated with a transient event.

Contact an IASD for information regarding a particular application or installation not covered in this manual.

NOTE: SPD is only included in specific models.

Specifications

Description	Rating
Surge Current Capacity Per Phase	50 kA
Nominal Discharge Current (In)	20 kA
Short Circuit Current Rating (SCCR)	200 kA
SPD Type	Rated Type 1 or Type 2
System Voltages Available: <ul style="list-style-type: none"> • Single Split-phase 	120/240 VAC
Protection Modes: <ul style="list-style-type: none"> • Single Split-phase 	L-N, L-L
Maximum Continuous Operating Voltage (MCOV)	150 L-N, 300 L-L
Input Power Frequency	50/60 Hz
Enclosure Rating	NEMA 4
Operating Temperature	-4°F through 122 °F (-40 °C through 70 °C)
Operating Humidity	5% through 95%, non-condensing
Operating Altitude	Up to 16,000 ft (5,000 m)
Agency Certification and Approvals	ETL per UL1449 4th Edition
Listed Device Warranty	Refer to Generac Residential Whole House Surge Protector Warranty Statement

Auxiliary Contacts

An optional, purchased separately, auxiliary contact kit G005621 is designed to work with the automatic transfer switch to lock out a single large electrical load from generator operation. If home is equipped with electrical heat or multiple central air conditioning units, this device allows the automatic transfer switch to interrupt the control wire, breaking the signal needed for appliance to turn on.

This page intentionally left blank.

Section 3: Installation

Introduction to Installation

Though this equipment has been wired and tested at the factory, the installer should verify all wiring connections are proper. Installing the switch includes the following procedures:

- Mounting the enclosure.
- Connecting power source and load leads.
- Connecting the generator start and sensing circuit.
- Connecting any auxiliary contact (if needed).
- Testing functions.

Mounting



Equipment Malfunction. Installing a dirty or damaged transfer switch will cause equipment malfunction and will result in death or serious injury.

(D000119)



Equipment Damage. Mount transfer switch to a strong, stable surface. Never mount to drywall, plaster, or other non-structural wall treatments. Failure to mount transfer switch to a strong, stable surface could result in equipment or property damage.

(C000814)

Mounting dimensions for the transfer switch enclosure are in this manual. Enclosures are typically wall-mounted. See [Drawings and Diagrams](#).

This transfer switch is mounted in a UL type 3R enclosure, which can be mounted outdoors or indoors and should be based on the layout of installation, convenience, and proximity to the utility supply and load center.

- Install the transfer switch as close as possible to the electrical loads which will be connected to it.
- Transfer switch must be mounted upright on a vertical rigid supporting structure to maintain UL type 3R rating.

If local Authority Having Jurisdiction (AHJ) requires a Remote Generator Emergency Shutdown switch, a kit is available from Generac to add this feature.

Generac Service Rated Transfer Switches (SE) are listed and labeled as "Suitable for use as service equipment." Generac SE rated Transfer Switches can be installed either as service equipment or not as service equipment.

Installation must comply with the applicable requirements in NEC.

- Where a Generac service-rated ATS is installed downstream of the utility metering equipment that does not contain a service disconnecting means, the ATS shall be installed as the service equipment in accordance with the requirements in NEC Article 230.
- Where a Generac service-rated ATS is not being installed as service equipment, the factory installed main bonding jumper shall be removed, and the ATS shall be installed not as service equipment and must comply with all applicable requirements of NEC Article 230 and 250.

Mounting

Mounting with Mounting Bracket Cleat

See [Figure 3-1](#). Secure mounting bracket cleat (A) to supporting structure through mounting holes (B).

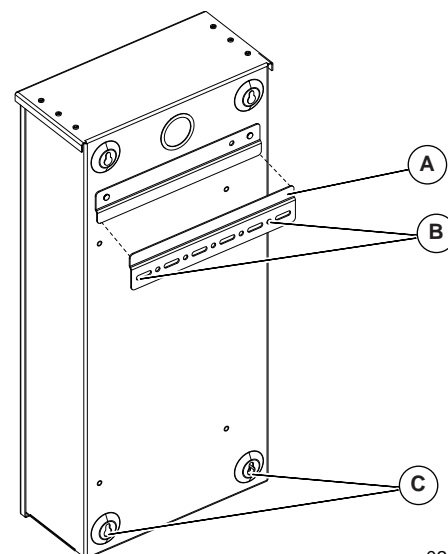

020082

Figure 3-1. Mounting Bracket Cleat

Fasteners must adequately secure the 35 lbs (15.9 kg) transfer switch weight to the supporting structure.

- Fasteners must be suitable for the mounting surface of supporting structure.
- Fasteners must engage at least two studs or other structural members on the supporting structure.
- Mounting bracket has clearance holes for 1/4" fasteners with slots to accommodate different stud spacings.

- Hang transfer switch onto mounting bracket after mounting bracket has been secured to supporting structure.
- See [Figure 3-1](#). Secure bottom of transfer switch to the supporting structure with two fasteners through mounting holes (C). Holes are spaced 10.5" (266.7mm) from each other. Use appropriate anchors or blocking as needed.

Mounting without Mounting Bracket Cleat

NOTE: Mounting bracket cleat cannot be removed from transfer switch.

Fasteners must adequately secure the 35 lbs (15.9 kg) transfer switch weight to the supporting structure.

- Fasteners must be suitable for the mounting surface of supporting structure.
- See [Figure 3-2](#). Remove top mounting key-holes (D).
- Press edge of a flat-head screwdriver against the pre-punched outline.
- Hit or tap the end of the screwdriver to remove or dislodge the knockout.
- See [Figure 3-2](#). Fasten transfer switch to supporting structure through mounting holes (D) and (E). Holes are spaced 10.5" (266.7mm) from each other. Use appropriate anchors or blocking as needed.

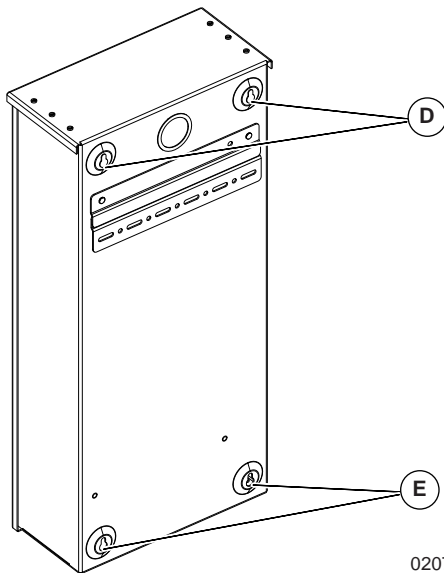

Figure 3-2. Mounting Transfer Switch without Utilizing Mounting Cleat

Open Enclosure

1. See [Figure 3-1](#). Remove outer cover (A):
 - a. Remove thumb screw (B).
 - b. Slide slot (C) over retention tab.
 - c. Lower cover until clear of top flange (D), and pull away from enclosure.
2. Remove inner panel (E):

NOTE: Inner Panel only available in models that are Service Entrance Rated.

- a. Loosen nut (F) until it clears t-slot (H) in inner panel.
- b. Grasp inner panel at two cutouts (G-left and right). Tilt inner panel as shown, passing nut through t-slot.
- c. Lower inner panel until clear of two retention slots (J-left and right sides), and pull away from enclosure.

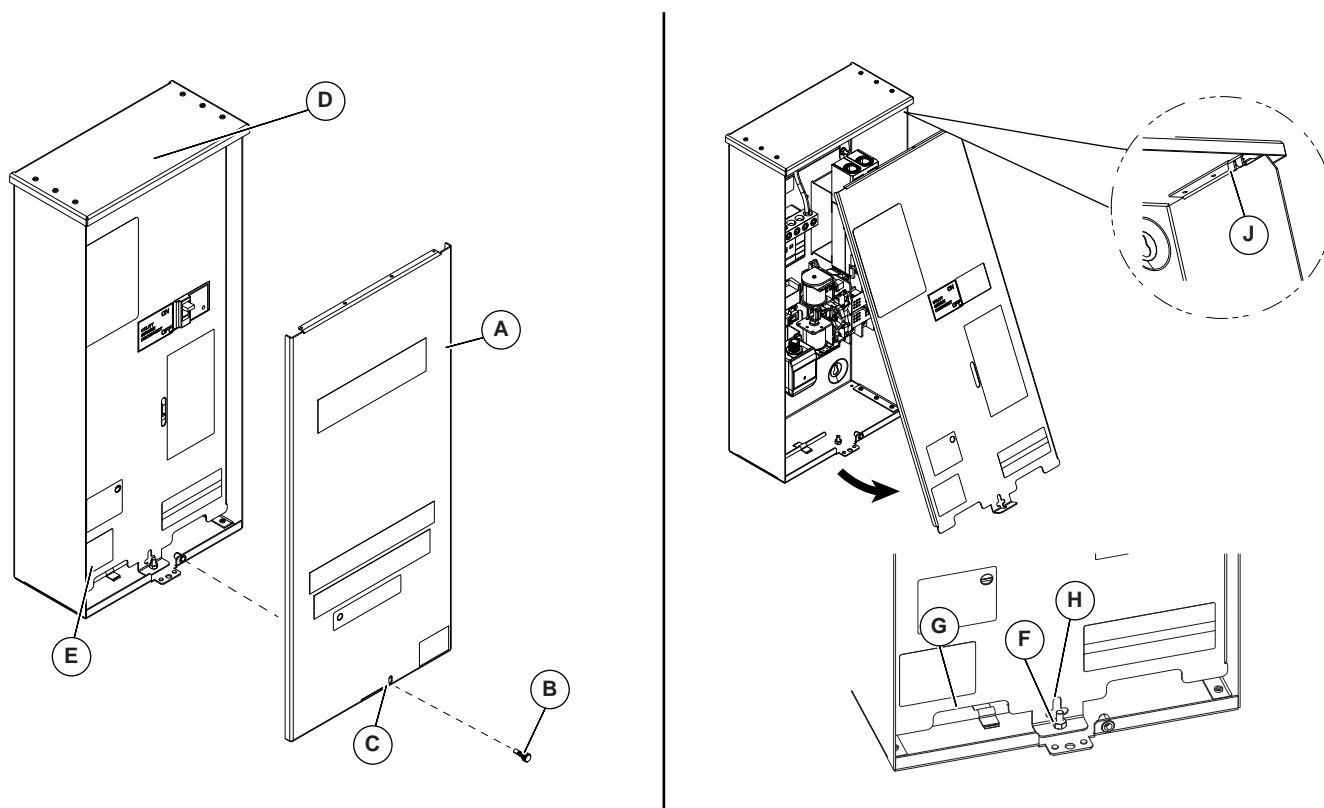

Figure 3-3. Open Enclosure

020007

Connecting Power Source and Generator Power Supply



⚠ DANGER

Electrocution. Turn utility and emergency power supplies to OFF before connecting power source and load lines. Failure to do so will result in death or serious injury.

(D000116)

⚠ CAUTION

Equipment damage. Verify all conductors are tightened to the factory specified torque value. Failure to do so could result in damage to the switch base.

(C000120)

Installation and interconnection diagrams are provided in this manual.

NOTE: All installations must comply with national, state and local codes. It is the responsibility of the installer to perform an installation that will pass the final electrical inspection.

Service Entrance Rated Models

1. Connect utility supply at the utility service disconnect circuit breaker terminals N1 and N2.

Follow torque specifications listed on the circuit breaker.

2. See [Figure 3-4](#). Connect utility neutral and ground to Neutral and Ground terminals. Neutral and Ground terminals are bonded to each other with a jumper wire (A).

NOTE: Neutral to Ground jumper wire (A) is provided for use on service entrance models if required by local codes.

3. Connect generator to the generator terminals (E1 and E2) on the transfer mechanism.
4. Connect the generator neutral wire to neutral lug.

IMPORTANT NOTE: A jumper wire (A) bonds the ground Neutral lug. Remove this wire if the transfer switch is not used as Service Equipment.

5. Connect a subpanel supply to lower T1 and T2 Terminals. Connect subpanel Neutral and Ground to Neutral and Ground bars.

NOTE: See [Figure 3-6](#). 100A rated models of the transfer mechanism come with factory installed terminal retention clip. Do not remove this clip during installation. Conductor sizes must be adequate to handle the maximum current to which they will be subjected, based on the 75°C column of tables, charts, etc. used to size

conductors. The installation must comply fully with all applicable codes, standards and regulations. Knockouts into the transfer switch can be made in the field as needed for entry of power cables and conduit. Conduit entry shall maintain the proper wire bending spaces required by Tables 312.6 (A) and (B) in the NEC. Conduits should be arranged to provide separation between the Utility and Generator supply conductors inside the enclosure.

For transfer switches installed in wet locations, power cables or conduits entering above the level of uninsulated live parts shall use fittings listed for use in wet locations as required by 312.2 in the NEC.

NOTE: If aluminum conductors are used, apply corrosion inhibitor to conductors. After tightening terminal lugs, carefully wipe away any excess corrosion inhibitor.

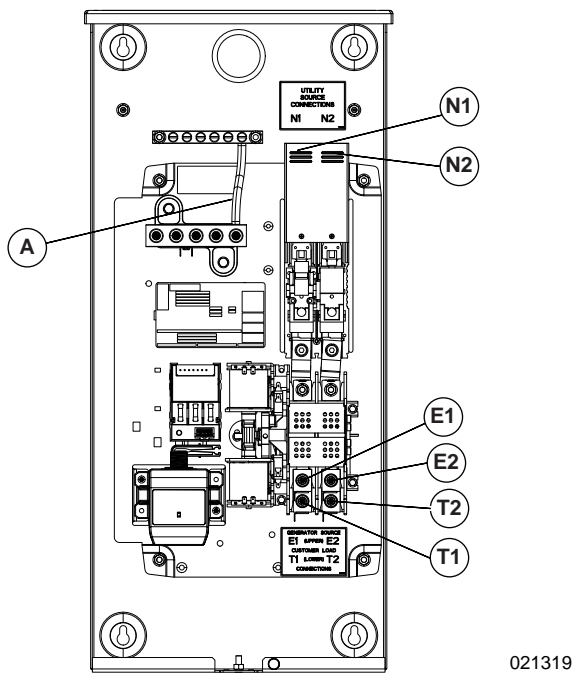

Figure 3-4. Wiring Connections (Service Entrance Rated Models)

Tighten terminal lugs to the torque values as noted on the decal located on the inside of the door. After tightening terminal lugs, carefully wipe away any excess corrosion inhibitor.

Non-Service Entrance Rated Models

1. See [Figure 3-5](#). Connect utility supply at the utility terminals (N1 and N2) on the transfer mechanism.

NOTE: Follow factory specified torque values.

2. Connect utility neutral and ground to Neutral and Ground terminals.

3. Connect generator to the generator terminals (E1 and E2) on the transfer mechanism.

NOTE: Follow factory specified torque values.

4. Connect the generator neutral wire to neutral lug.

5. Connect a subpanel supply to the lower load terminals (T1 and T2).

NOTE: Follow factory specified torque values.

6. Connect subpanel Neutral and Ground to Neutral and Ground bars.

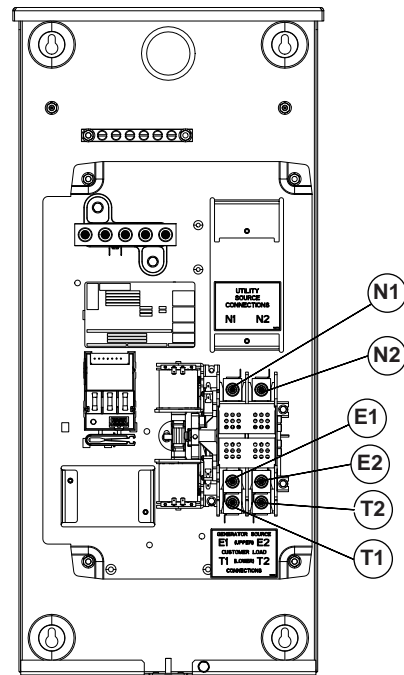

Figure 3-5. Wiring Connections (Non-Service Entrance Rated Models)

NOTE: See [Figure 3-6](#). 100A rated models of the transfer mechanism come with factory installed terminal retention clips (A). Retention clips are intended to secure lugs to the transfer switch prior to install of conductors in terminals N1, N2, E1, E2, T1, and T2. Do not remove this clip during installation.

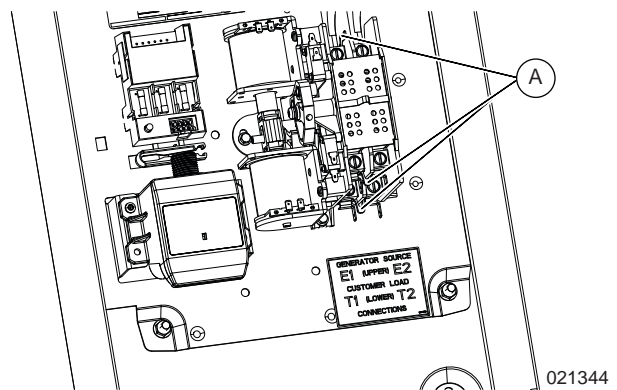

Figure 3-6. 100A Terminal Retention Clips

Connecting Start Circuit Wires

See [Figure 3-7](#). Control system interconnections consist of N1, N2, and T1, and leads 23, 194, and 0.

NOTE: Generac Type TC-ER-JP power and control tray cable can be installed as permitted by the 2017 NEC. Type TC-ER-JP cable contains color-coded power and control conductors.

The generator control wiring is a Class 1 signaling circuit. Reference instruction manual of specific engine generator for wiring connection details. Screw heads are straight bladed and cross-bladed, and should be tightened to 3.5 in-lb (0.4 Nm).

Recommended minimum wire gauge is No. 18 AWG, up to 500 ft (152.4 m). Terminals are listed for copper conductors only.

Exception: Conductors of AC and DC circuits, rated 1000 volts nominal, or less, shall be permitted to occupy the same equipment, cable, or conduit. All conductors shall have an insulation rating equal to at least the maximum circuit voltage applied to any conductor within the equipment, cable, or conduit. See NEC 300.3(C)(1).

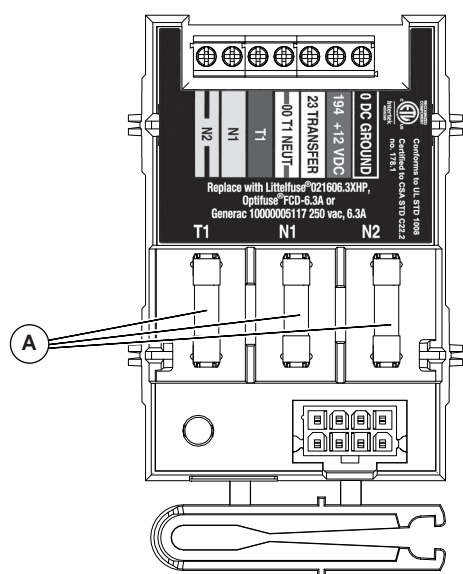

Figure 3-7. Typical Connections

NOTE: 0 - Ground (black) is not required. If a ground wire is included in the tray cable, wire can be connected for later use.

Customer Wiring Connections Integrated Fused Control Module (FCM)	
Terminal Numbering Decal	Wire Numbers
BLACK	0—DC (-) Not required
RED	194—DC (+) 12 VDC for transfer controls
WHITE	23—Transfer control signal wire
WHITE AND BLACK	00—Dedicated T1 Neutral
BLUE*	T1—Fused 120 VAC for battery charger
YELLOW	N1—Fused 240 VAC Sensing for utility dropout and pickup
YELLOW WITH BLACK STRIPE	N2—Fused 240 VAC Sensing for utility dropout and pickup

* Required to supply utility or generator voltage to the generator battery charger.

020857

Typical Fuse Control Module Connections

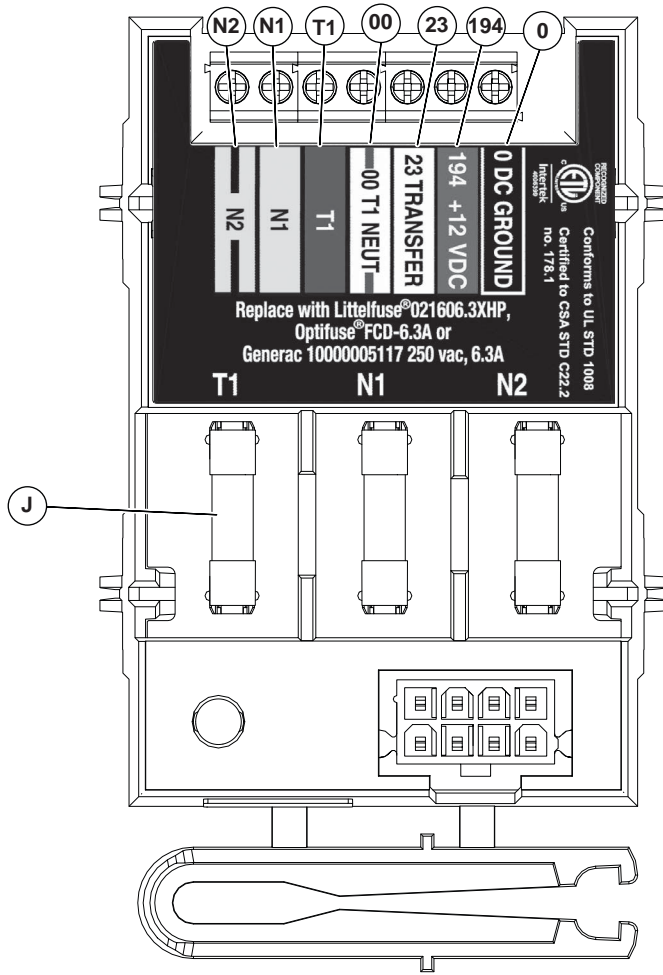

Figure 3-8. Typical Fuse Control Module Connections

0 DC Ground
194 + 12 VDC
23 Transfer Control
00 Dedicated T1 Neutral
T1 (fused) Battery Charge
N1 (fused) Utility Sense
N2 (fused) Utility Sense
J 240 VAC, 6.3A Fuses

Fault Current Label

See [Figure 3-9](#). A Fault Current Identification Label is provided in the bag containing the unit Owner's Manual and transfer switch manual operating handle. The 2017 NEC requires that the short-circuit current rating of the transfer equipment, based on the type of overcurrent protective device protecting the transfer equipment, be field marked on the exterior of the transfer equipment. For NEC compliance, verify the required short-circuit current rating of the transfer switch before installation. The completed label provides the local AHJ (Authority Having Jurisdiction) with the information he or she may require during inspection.

Apply the label to the exterior of the transfer switch enclosure. Use a pen to fill in the required information, and then cover the label with the clear protective decal.

FAULT CURRENT RATING _____
AVAILABLE FAULT CURRENT _____
DATE _____

004496

Figure 3-9. Fault Current Label

This page intentionally left blank.

Section 4: Operation

Functional Tests and Adjustments



⚠ WARNING

Electrocution. Refer to NFPA 70E for PPE and safety equipment before work.

(W000221)

⚠ CAUTION

Equipment damage. Perform functional tests in the exact order they are presented in the manual. Failure to do so could result in equipment damage.

(C000121)

Following transfer switch installation and interconnection, inspect the entire installation carefully. A competent, qualified electrician should inspect it. The installation should comply strictly with all applicable codes, standards, and regulations. When absolutely certain the installation is proper and correct, complete a functional test of the system.

IMPORTANT NOTE: Before proceeding with functional tests, read and make sure all instructions and information in this section is understood. Also read the information and instructions of labels and decals affixed to the switch. Note any options or accessories that might be installed and review their operation.

Manual Operation



⚠ DANGER

Electrocution. Do not manually transfer under load. Disconnect transfer switch from all power sources prior to manual transfer. Failure to do so will result in death or serious injury, and equipment damage.

(D000132)

⚠ CAUTION

Equipment damage. Do not use excessive force while manually operating the transfer switch. Doing so could result in equipment damage.

(C000122)

See [Figure 4-2](#). A manual handle (C) is shipped with the transfer switch's loose parts kit in the event that automatic operation of the system has failed. Manual operation must be checked BEFORE the transfer switch is operated electrically. To check manual operation, proceed as follows:

1. Verify the generator's main circuit breaker is in the OFF mode.
2. See [Figure 4-1](#). Turn OFF both utility (service disconnect circuit breaker) (A) and emergency (generator main line circuit breaker) power supplies to the transfer switch.

NOTE: Refer to generator's owner's manual for generator main line circuit breaker location.

NOTE: For non-service entrance rated models, the utility service disconnect will be upstream from transfer switch panel. Refer to site's unique requirements and electrical configuration. Disconnection from utility power occurs in a separate box or in the site's main panel.

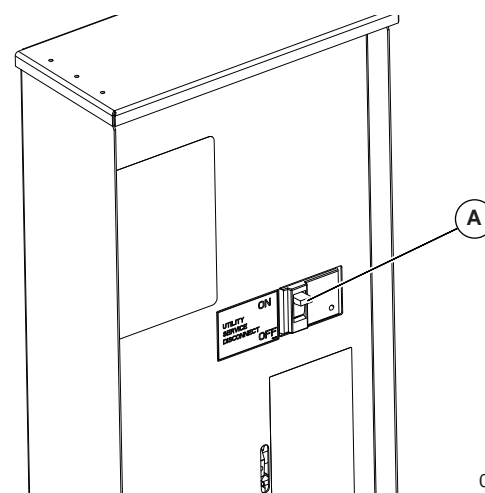

021342

Figure 4-1. Utility Service Disconnect (Service Entrance Rated Transfer Switches)

3. See [Figure 4-2](#). Note position of transfer mechanism main contacts (B) by observing the movable contact carrier arm.

NOTE: For service entrance rated models, the transfer mechanism will be located behind the interior cover. The transfer mechanism can be accessed through the interior cover's narrow slot. Transfer switch position can be observed through the narrow slot of the interior cover. The front of the movable transfer mechanism is yellow and can be easily identified.

- a. Manual operation handle in the UP position - LOAD terminals (T1, T2) are connected to utility terminals (N1, N2). Transfer switch is now connected to utility (grid) power.
- b. Manual operation handle in the DOWN position - LOAD terminals (T1, T2) are connected to EMERGENCY terminals (E1, E2). Transfer

switch is now connected to generator (emergency) power.

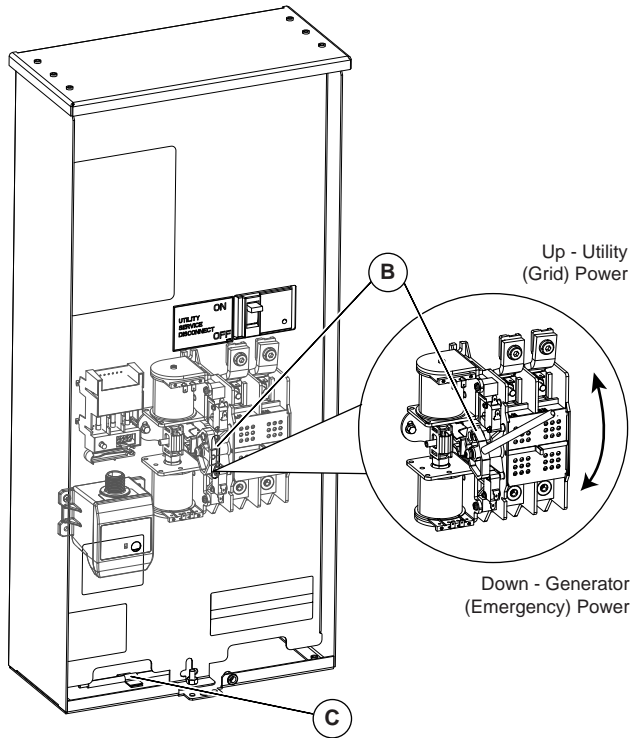

021322

Figure 4-2. Manual Operation

In the case of automatic operation not occurring, contact a local Independent Authorized Service Dealer (IASD) to investigate, diagnose, and service the system to identify why automatic operation did not occur.

Manual Transfer to Utility Source Side

Proceed with the following steps in the event that utility (grid) power has returned, but the transfer switch has not supplied the available utility power to the residence.

Verify the position of the switch by observing the position of manual operation handle in the transfer mechanism. If the handle is UP, the contacts are closed in the utility (normal) position, no further action is required. If the handle is DOWN, proceed with Step 1.

1. With the handle inserted into the yellow movable contact carrier rocker, move handle UP. Hold on to the handle as it will move quickly after passing the center of travel.
2. Remove manual operating handle from movable contact carrier rocker. Return handle to storage bracket in the transfer switch for future use.
3. Turn ON utility service disconnect service breaker.
 - a. For service entrance rated transfer switch models, see [Figure 4-1](#).
 - b. For non-service entrance rated transfer switch models, refer to site's electrical configuration for utility power disconnect.

4. Turn ON generator main circuit breaker.

Manual Transfer to Generator Source Side

Before proceeding, verify the position of the switch by observing the position of the manual operation handle in the transfer mechanism. If the handle is DOWN, the contacts are closed in the generator (standby) position. No further action is required. If the handle is UP, proceed with Step 1.

1. With the handle inserted into the yellow movable contact carrier rocker, move the handle DOWN. Hold on to the handle as it will move quickly after passing the center of travel.
2. Remove manual operating handle from movable contact carrier rocker. Return handle to storage bracket in the transfer switch for future use..
3. Turn ON utility service disconnect service breaker.
 - a. For service entrance rated transfer switch models, see [Figure 4-1](#).
 - b. For non-service entrance rated transfer switch models, refer to site's electrical configuration for utility power disconnect.
4. Turn ON generator main circuit breaker.

Voltage Checks

NOTE: Use the Digital Multimeter (DMM) LowZ low input impedance setting to collect accurate voltage measurements. LowZ eliminates the possibility of inaccurate ghost voltage readings, also known as phantom voltage or stray voltage readings. See DMM manufacturer's literature for additional information.

Utility Voltage Checks



⚠ DANGER

Electrocution. High voltage is present at transfer switch and terminals. Contact with live terminals will result in death or serious injury.

(D000129)



⚠ WARNING

Electrocution. Refer to NFPA 70E for PPE and safety equipment before work.

(W000221)

1. Turn ON the utility power supply to the transfer switch using the utility service disconnect circuit breaker.
2. With an accurate AC voltmeter, check for correct voltage. Measure across ATS terminal lugs N1 and N2; N1 to NEUTRAL and N2 to NEUTRAL.

Generator Voltage Checks



⚠ DANGER

Electrocution. High voltage is present at transfer switch and terminals. Contact with live terminals will result in death or serious injury.

(D000129)



⚠ WARNING

Electrocution. Refer to NFPA 70E for PPE and safety equipment before work.

(W000221)

1. On the generator panel, select the MANUAL mode of operation. The generator should crank and start.
2. Let the generator stabilize and warm up at no-load for at least five minutes.
3. Set the generator's main circuit breaker (CB1) to its ON or CLOSED position.
4. With an accurate AC voltmeter and frequency meter, check the no-load, voltage and frequency. Measure across ATS terminal lugs E1 to E2; E1 to NEUTRAL and E2 to NEUTRAL.

Frequency	60–62 Hz
Terminals E1 to E2	240–246 VAC
Terminals E1 to NEUTRAL	120–123 VAC
Terminals E2 to NEUTRAL	120–123 VAC

5. When certain that generator supply voltage is correct and compatible with transfer switch ratings, turn OFF the generator supply to the transfer switch.
6. Set the generator main circuit breaker (CB1) to OFF or OPEN.
7. On the generator panel, select the OFF mode to shut down the generator.

Do NOT proceed until generator AC output voltage and frequency are correct and within stated limits. If the no-load voltage is correct but no-load frequency is incorrect, the engine governed speed may require adjustment. If no-load frequency is correct but voltage is not, the voltage regulator may require adjustment.

Generator Tests Under Load

NOTE: Below steps are applicable for Generac Generator and Generac Transfer Switch.

1. Set the generator main circuit breaker to OFF or OPEN.

2. Set the utility service disconnect circuit breaker of the transfer switch to OFF or OPEN, and turn OFF or OPEN all load circuit breakers.
3. Manually actuate the transfer switch main contacts to the emergency (standby) position. See [Manual Operation](#).
4. To start the generator, select the MANUAL mode of operation. When engine starts, let it stabilize for a few minutes.
5. Set the generator main circuit breaker to ON or CLOSED, and close lid (if applicable). The generator now powers all LOAD circuits. Check generator operation under load as follows:
 - a. Turn on electrical loads to the full rated wattage/amperage capacity of the generator. **DO NOT OVERLOAD.**
 - b. With maximum rated load applied, check voltage and frequency across transfer switch terminals E1 and E2. Voltage should be greater than 230 VAC (240 VAC system); frequency should be greater than 59 Hz.
 - c. Verify that the gas pressure remains within acceptable parameters (see the generator Installation manual).
 - d. Let the generator run under rated load for at least 30 minutes. With unit running, watch for unusual noises, vibration, or overheating that might indicate a problem.
6. When checkout under load is complete, set main circuit breaker of the generator to the OFF or OPEN position.
7. Let the generator run at no-load for several minutes. Then, shut down by selecting the OFF mode.
8. Set the main circuit breaker of the generator back to ON or CLOSED position once generator is shutdown.
9. Move the main switch contacts back to the utility position.

NOTE: See [Manual Operation](#). Handle and operating lever of transfer switch should be in down position.
10. Set the utility service disconnect circuit breaker of the transfer switch to ON or CLOSED.
11. Select AUTO on the generator panel.

The system is now set for fully automatic operation.

Checking Automatic Operation

To check the system for proper automatic operation, proceed as follows:

1. Verify generator is OFF.

2. Set the utility service disconnect circuit breaker of the transfer switch to OFF or OPEN.
3. Verify switch is de-energized.
4. Install front cover of the transfer switch.
5. Set the utility service disconnect circuit breaker of the transfer switch to ON or CLOSED.
6. Set the generator main circuit breaker to ON.
7. On the generator panel, select AUTO. The system is now ready for automatic operation.
8. Set the utility service disconnect circuit breaker of the transfer switch to OFF or OPEN.

With the generator ready for automatic operation, the engine should crank and start when the utility source power is turned OFF after a five second delay (factory default setting). After starting, the transfer switch should connect load circuits to the standby side after a five (5) second warm-up delay. Let the system operate through its entire automatic sequence of operation.

NOTE: Timer durations may differ between generators and settings.

With the generator running and loads powered by generator AC output, set the utility service disconnect circuit breaker of the transfer switch to ON or CLOSED.

The following should occur:

- After approximately 15 seconds, the switch should transfer loads back to the utility power source.
- Approximately one minute after re-transfer, the generator should shut down.

With the generator in the AUTOMATIC mode, the system is now set for fully automatic operation.

Surge Protection Device Operation (Select Models Only)

After transfer switch installation, a surge event, or a major weather event, check the SPD's LED for operation.

1. See [Figure 4-3](#). Apply system power. LED (A) should illuminate.

NOTE: If connected LED does not illuminate, remove power, check connections, and test again. If LED still does not light, contact an IASD.

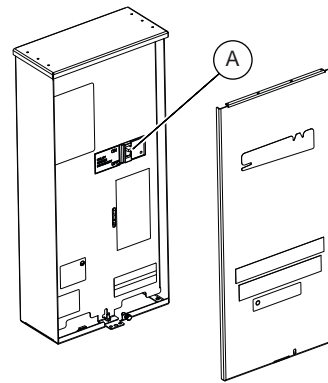

021343

Figure 4-3. SPD LED Light

2. SPD will automatically begin to protect downstream electrical devices from damaging voltage transients.

With all phase voltages present, LED indicator reports the status of the protection elements and is active when all of them are intact and providing protection. Any loss of protection is signaled when LED turns OFF.

NOTE: The SPD itself is not repairable and contains no user serviceable parts. If SPD fails, as evidenced by unlit LED indicator, contact an IASD for a replacement.

IMPORTANT NOTE: Do NOT use the Suppression Circuit Status LEDs as an indication of the presence or absence of system phase voltages.

Installation Summary

1. Verify the installation has been properly performed as outlined by the manufacturer and that it meets all applicable laws and codes.
2. Verify proper operation of the system as outlined in the appropriate installation and owner's manuals.
3. Educate the end-user on the proper operation, maintenance and service call procedures.

NOTE: The Utility Power Circuit Breaker in the transfer switch must be turned OFF to simulate a utility outage. Shutting off the main disconnect in a subpanel connected to the transfer switch will NOT simulate an outage.

Shutting Generator Down While Under Load or During a Utility Outage



Automatic start-up. Disconnect utility power and render unit inoperable before working on unit. Failure to do so will result in death or serious injury.

(D000191)

IMPORTANT NOTE: To avoid equipment damage, follow these steps, in order, during utility outages. Shutdowns may be required during utility outages to perform routine maintenance or to conserve fuel.

1. To turn generator OFF:
 - a. Set utility main line circuit breaker (MLCB) to OFF (OPEN).
 - b. Set generator MLCB to OFF (OPEN).
 - c. Allow generator to run for cool-down for approximately five (5) minutes.
 - d. Set generator to OFF at the controller.
 - e. Remove 7.5A fuse from controller.
2. To turn generator back ON:
 - a. Install 7.5A fuse in controller.
 - b. Verify generator MLCB (generator disconnect) is OFF (OPEN).
 - c. Set generator to AUTO mode at the controller.
 - d. Generator will start and run. Allow generator to run and warm up for a few minutes.
 - e. Set generator MLCB (generator disconnect) to ON (CLOSED).
 - f. Set utility MLCB to ON (CLOSED).

The system now operates in automatic mode.

Testing a Load Manager

Refer to the Load Manager Owner's or Installation Manual for the proper testing procedure.

FCM Fuse Service



⚠ DANGER

Electrocution. High voltage is present at transfer switch and terminals. Contact with live terminals will result in death or serious injury.

(D000129)



⚠ WARNING

Electrocution. Refer to NFPA 70E for PPE and safety equipment before work.

(W000221)

See [Figure 4-4](#). A fuse removal and installation tool (A) is included in the FCM housing.

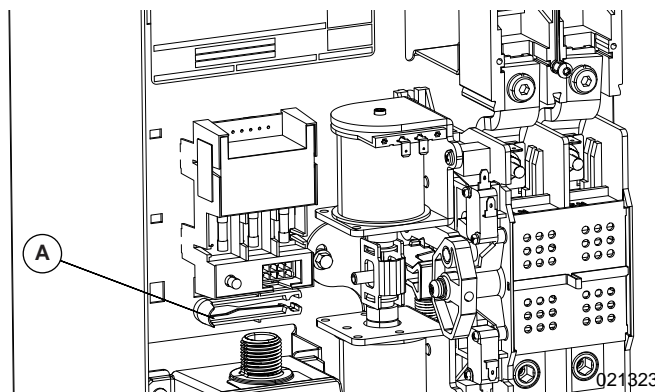

Figure 4-4. Fuse Removal and Installation Tool

If a fuse requires replacement, snap the tool free with an appropriate, electrically insulated tool, such as diagonal pliers, and use it to replace the fuse. Do NOT touch any part of the fuse with anything other than the included fuse removal and installation tool until the fuse is completely removed from the FCM. The tool can be stored in the FCM housing retainer directly above the fuses, with the large thumb tab facing out.

Use only Generac replacement fuses — part number 1000005117, rated 240 VAC, 6.3 Amps, 10,000 AIC.

This page intentionally left blank.

Section 5: Drawings and Diagrams

Installation Drawing—100A/150A/200A Install with Cleat

No. A0006058193-B

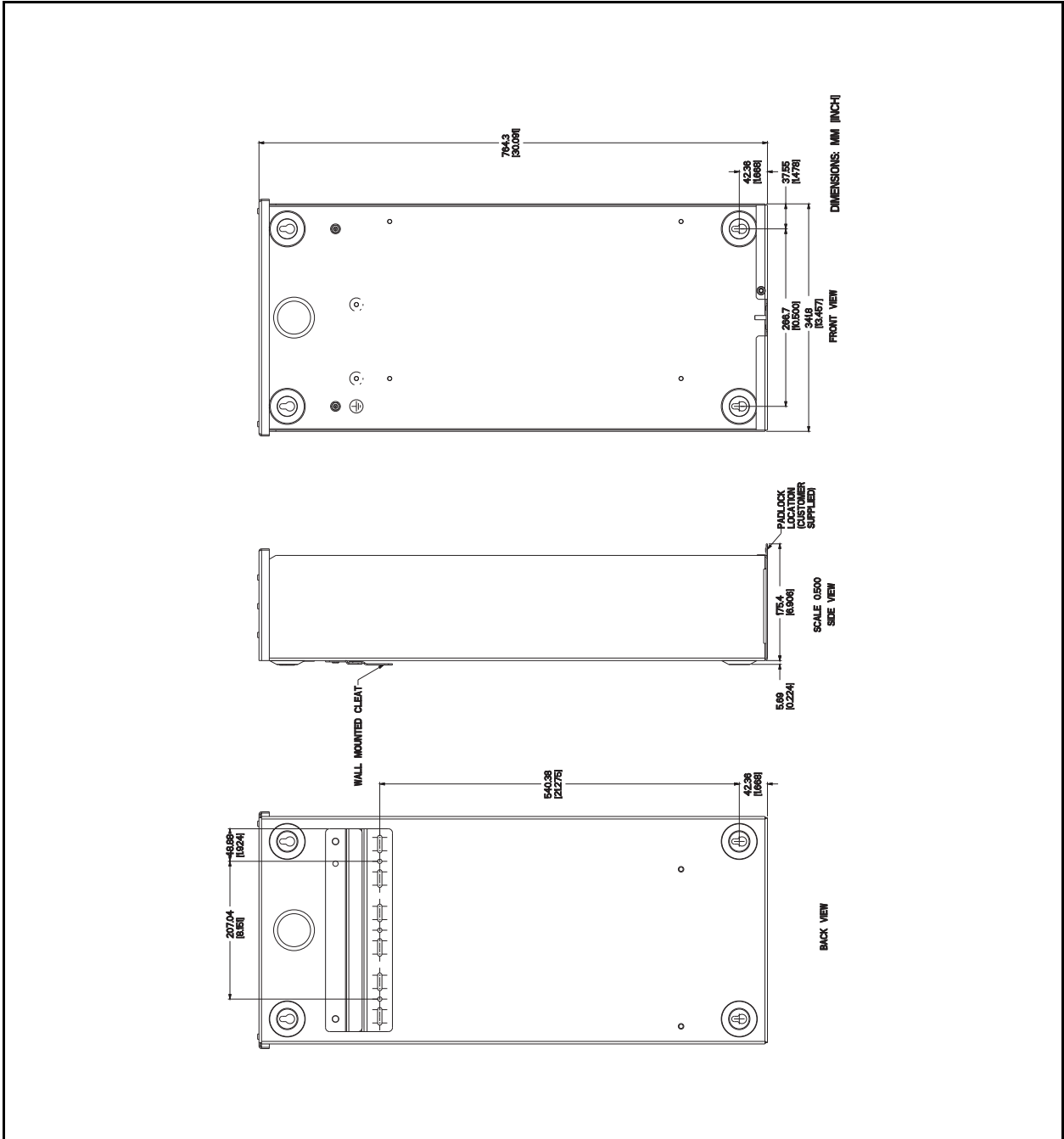

Installation Drawing—100A/150A/200A Install Without Cleat

No. 10000012171-A

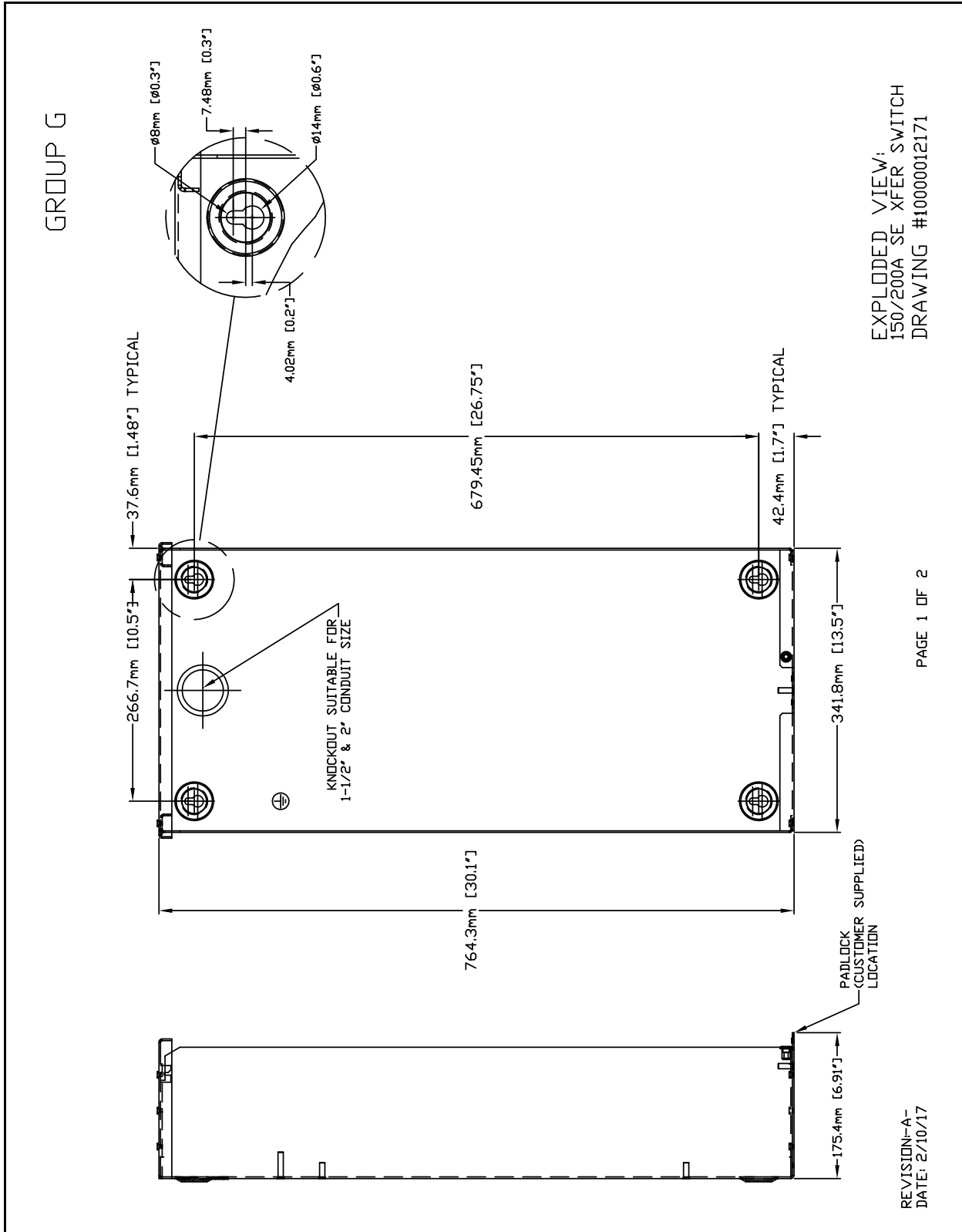

Installation Drawing—Liquid Cooled Generator

No. A0006058269-B (Part 1 of 2)

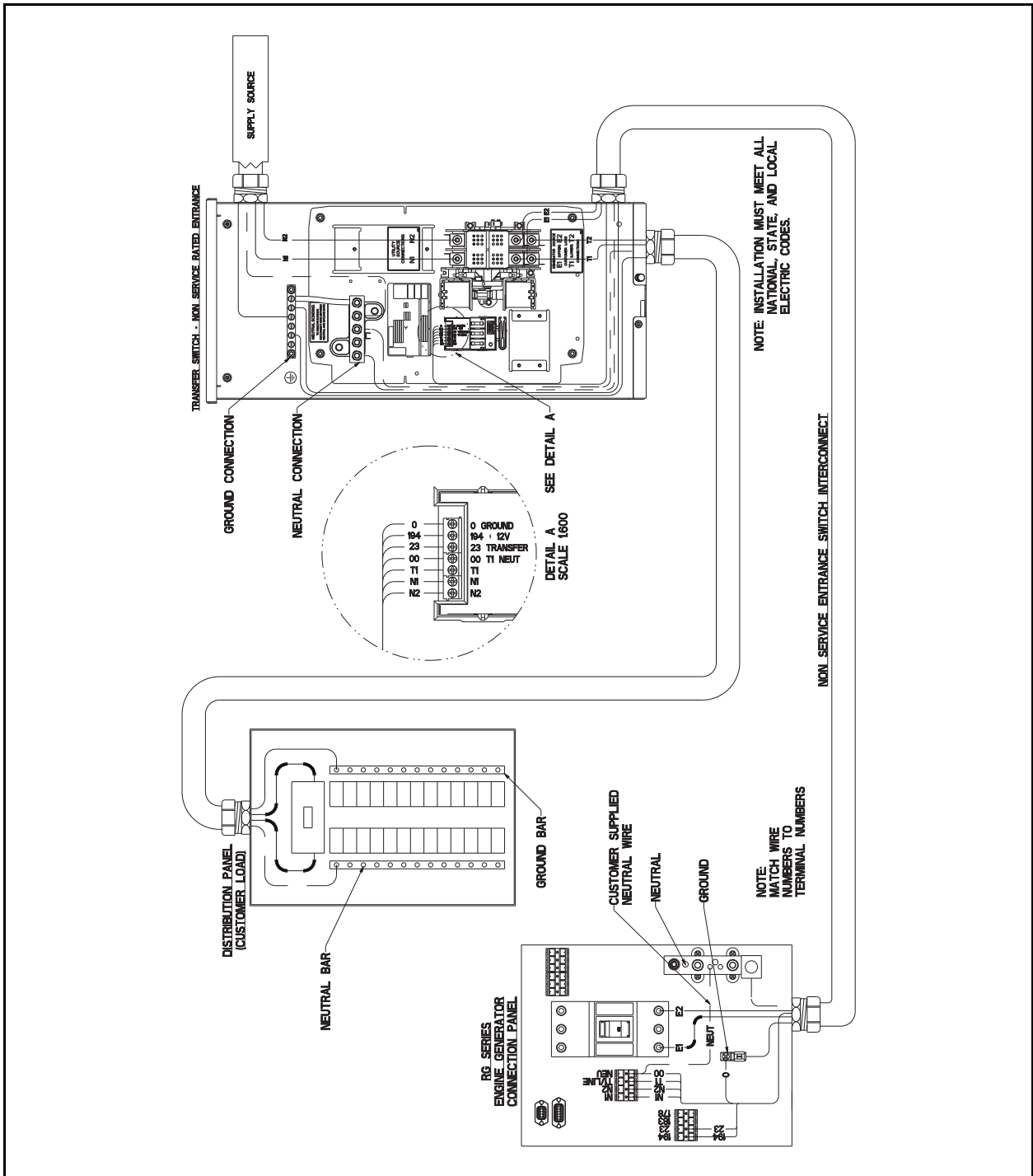

Installation Drawing—Liquid-Cooled Generator

No. A0006058269-B (Part 2 of 2)

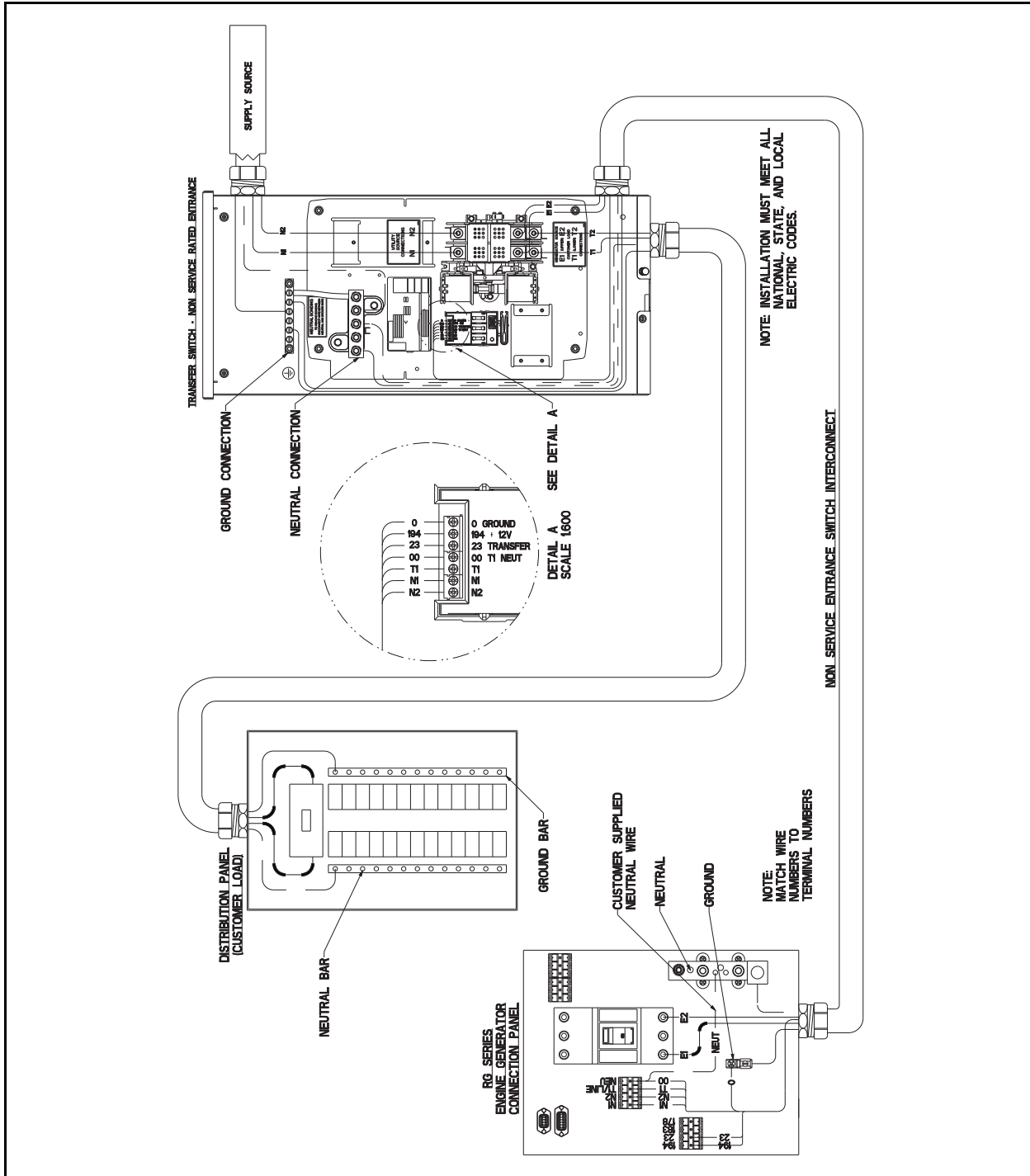

Installation Drawing—Air-Cooled Generator SE and Non-SE Rated ATS

No. A0006059371-B (Part 1 of 2)

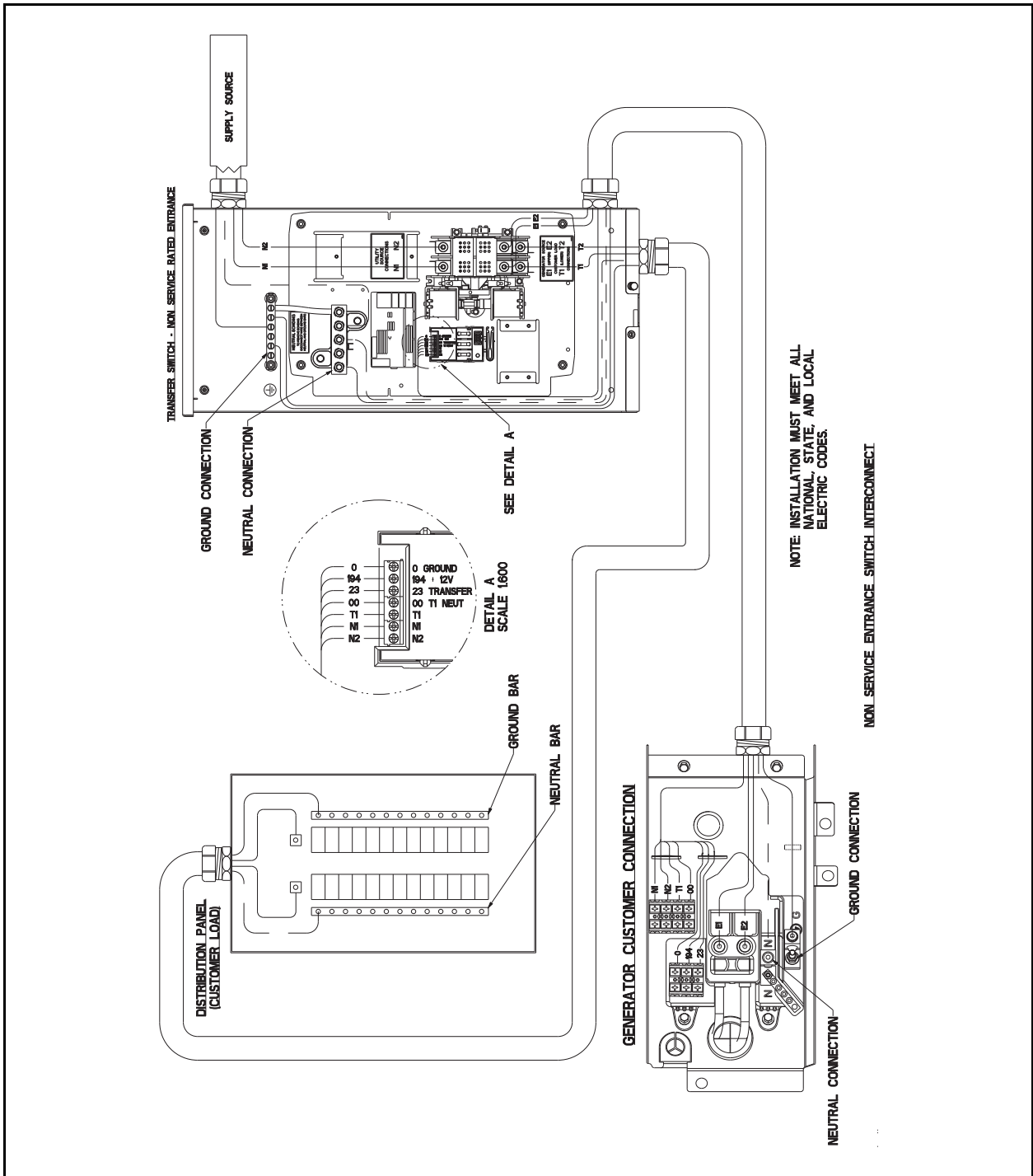

Installation Drawing—Air-Cooled Generator SE and Non-SE Rated ATS

No. A0006059371-B (Part 2 of 2)

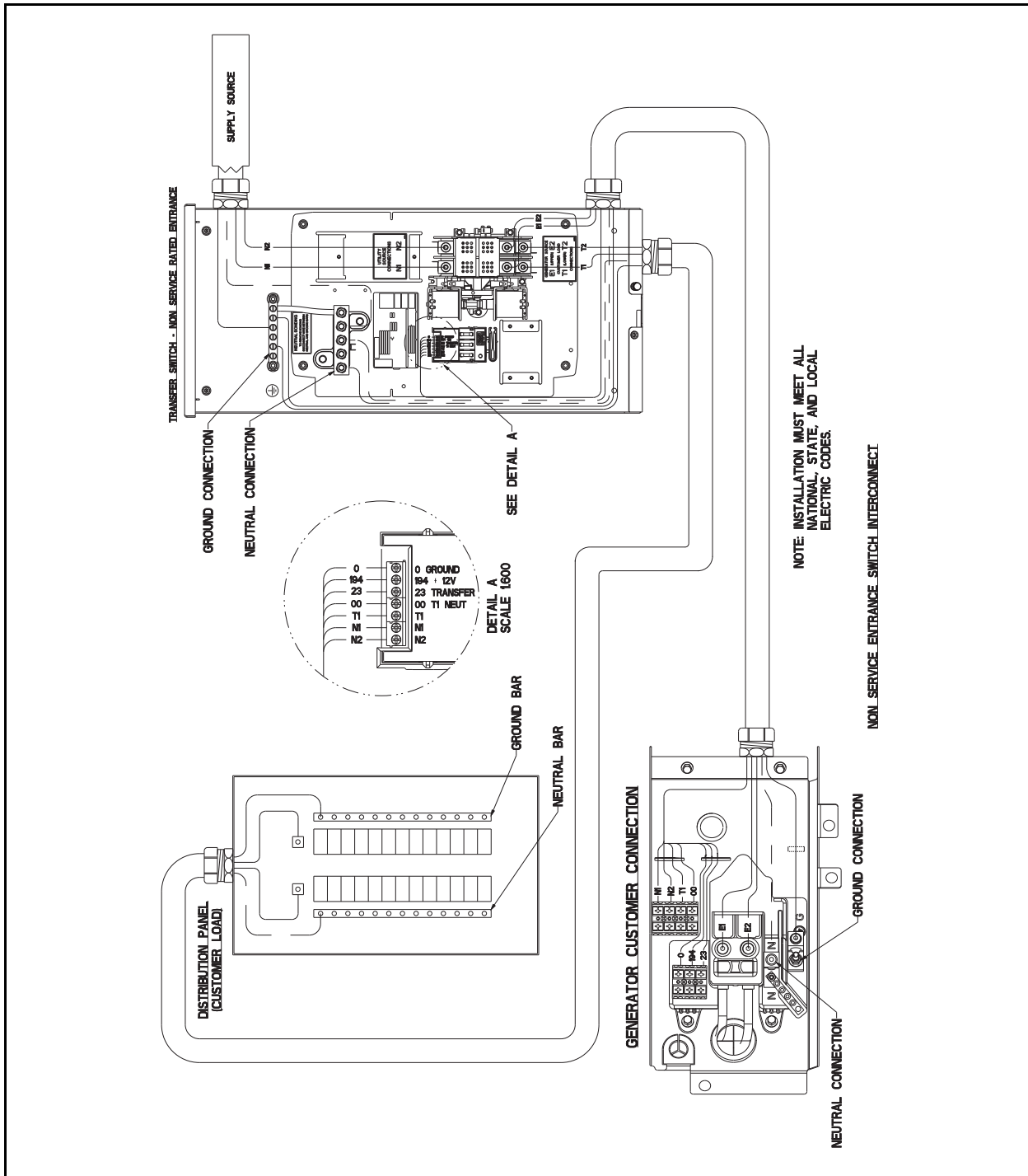

This page intentionally left blank.

This page intentionally left blank.

Part No. A0009313194 Rev. A 9/26/2025
© 2025 Generac Power Systems, Inc.
All rights reserved.
Specifications are subject to change without notice.
No reproduction allowed in any form without prior written
consent from Generac Power Systems, Inc.



Generac Power Systems, Inc.
S45 W29290 Hwy. 59
Waukesha, WI 53189
1-888-GENERAC (1-888-436-3722)
www.generac.com