

**MDG150DF4 | 6.8L | 120 kW**

**MOBILE DIESEL GENERATOR SET**

EPA Emissions Certification: Tier IV Final

**GENERAC® | MAGNUM**

**Standby Power Rating**

144 kW, 180 kVA, 60 Hz

**Prime Power Rating**

120 kW, 150 kVA, 60 Hz



Image used for illustration purposes only

**Codes and Standards**

Generac Magnum products are designed to the following standards:



CSA Certified



NATM



TIER 4 FINAL EMISSIONS



ISO 8528-5

**Power When and Where You Need It**

Generac Magnum mobile diesel generators are designed and engineered to power a variety of projects, in the most extreme environments. Gensets are configured to meet customer needs, including choice of containment, cold weather packages, trailer options, and more.

Generac Magnum mobile diesel generators are manufactured to deliver reliable power, when and where you need it.

**STANDARD FEATURES**

**ENGINE SYSTEM**

- John Deere® 6068HFG05 – turbocharged + after-cooled, diesel engine
- Six cylinder
- 415 in<sup>3</sup> (6.8 L) displacement
- Tier 4 Final (SCR + DOC)
- Rubber vibration dampers isolate engine/generator from frame
- Disposable air filter – paper element
- Variable Geometry Turbocharger (VGT)
- Electronic isochronous governing
- Variable speed fan drive

**Fuel System**

- Steel, double wall fuel tank
- 110% fluid containment
- 358 gal. (1355 L) diesel tank capacity
  - 39 hr run time – full load
- 34.4 gal (130.4 L) DEF tank capacity
- DEF consumption rate:
  - 100% standby – 0.34 gph (1.3 Lph)

**Cooling System**

- Capable of operating at 120 °F (49 °C) ambient
- Low coolant shutdown
- Radiator and oil drains plumbed to exterior

**SYSTEM OUTPUTS**

- 3-position selector switch (lockable)
  - Single phase – 120 / 240V Zig Zag
  - Three phase – 120 / 208V Low Wye
  - Three phase – 277 / 480V High Wye
- 114 kW / 114 kVA – standby, single phase
- 108 kW / 108 kVA – prime, single phase
- 144 kW / 180 kVA – standby, three phase
- 120 kW / 150 kVA – prime, three phase

**GENERATOR**

- Marathon Electric
  - Brushless
  - 4-pole
  - Class H insulation
- Voltage regulation ± 1.0% with PM600 Voltage Regulator

**ENCLOSURE**

- Aluminum, sound attenuated enclosure
  - UV and fade resistant, high temperature cured, white polyester powder paint
  - Insulated and baffled
  - 75 dB(A) at 23 ft (7 m) – prime power
- Fully lockable enclosure including doors and fuel fill
- Emergency stop switch located on outside of enclosure

- Central lifting point
- Multi-lingual operating/safety decals
- Document holder with operating manual including AC/DC wiring diagrams

**TRAILER**

- DOT approved tail, side, brake, and directional lights; recessed rear lights
- Transportation tie downs
- Safety chains with spring loaded safety hooks
- 3 in (76.2 mm) lunette ring hitch
- Two 8000 lb (3629 kg) axles with surge brakes
- 10000 lb (4536 kg) tongue jack with footplate
- ST215/75R17.5 tubeless tires – 10 ply

**WARRANTY**

- 1 year unlimited
- 2 years / 2000 hours

**CERTIFICATIONS**

- CSA Certified

**SYSTEM CONTROLS**

**Power Zone® Controller And Display**

- Backlit, 800 x 480 pixel resolution color display
- -40 °F to 185 °F (-40 °C to 85 °C) operating temperature range
- Automatic coarse voltage adjustment
- Integrated fine voltage adjustment
- PLC functionality

**Push Buttons For Easy Operation**

- Manual or Auto Start
- Engine Start
- Engine Stop/Reset
- Alarm Mute
- Operator Screens
  - Home
  - Engine
  - Generator
  - Voltage Adjust

**Scrolling Arrows for Diagnostic Information**

- Engine diagnostic display
  - Oil pressure
  - Engine temperature
  - Fuel level
  - Battery
  - Aftertreatment inlet/outlet temperature
  - Ash/soot levels

- Generator diagnostic display
  - System kW output display
  - Line output and frequency display
- Alarms
  - Warning
  - Shutdown
  - Electrical Trip
  - Engine
- Alarm list – warnings/shutdowns; 250 even history log – date/time stamp
  - Fuel level: warning – 15%; shutdown – 5%
  - Overspeed protection: shutdown – 115%
  - Oil pressure: warning – 24 psi (165.5 kPa); shutdown – 19 psi (131.0 kPa)
  - Coolant temperature: warning – 230 °F (110 °C); shutdown – 235 °F (113 °C)
  - Battery voltage: over – 15VDC; under – 11VDC
  - Generator over voltage: warning – 110%; electrical trip – 125%
  - Generator under voltage: warning – 91.4%; shutdown – 70%
  - Generator over frequency: warning – 102.5%; electrical trip – 110%
  - Generator under frequency: warning – 95%; electrical trip – 90%

- Inputs/outputs
- Auto schedule
- Status
- Configuration of controller, firmware, and connections

**ELECTRICAL CONTROLS**

- Remote start/stop contacts located in the receptacle box.
- Lockable control box door with diagnostics window
- Lockable lug box with safety switch
  - Trips main breaker when door is opened
  - Disables voltage regulator
- Output ground connection lug inside lug box
- 600A main breaker with shunt trip
- Convenience receptacles with individual breakers (restricted use in high wye mode)
  - Two 120V 20 amp GFCI duplex outlets – (NEMA 5-20R type)
  - Three 240V 50 amp, 3-pole, 4-wire Twistlock (Non-NEMA 6369)
- Voltage adjustment integrated into Power Zone controller, ± 10%
- Two 12V / 1000 CCA wet cell batteries
- Battery disconnect switch

**MDG150DF4 | 6.8L | 120 kW**

**MOBILE DIESEL GENERATOR SET**

EPA Emissions Certification: Tier IV Final

**GENERAC® | MAGNUM**

## OPTIONS

### POWERTRAIN SYSTEM

- Block heater
- Fuel filter heater
- CCV heater
- 60/40 coolant
- Positive air shutdown
- Engine oil reservoir
- Cam locks
- 10A battery charger

### TRAILER

- Full size spare tire
- Tool box / storage bin
- 2-5/16" (5.9 cm) ball
- Electric brakes

### CABINET

- Auxiliary fuel connection for day tank
- 36 hour tank
- Fire extinguisher

### CONTROL SYSTEM

- 4-position selector switch
- PMG/DVR
- Paralleling
- Buck transformer



## RATING DEFINITIONS

Standby - Applicable for varying emergency load for the duration of a utility power outage.

Prime - Applicable for supplying power to a varying load in lieu of utility for an unlimited amount of running time.

\*Consult factory for availability

# MDG150DF4 | 6.8L | 120 kW

## MOBILE DIESEL GENERATOR SET

EPA Emissions Certification: Tier IV Final



### APPLICATION AND ENGINEERING DATA

#### ENGINE SPECIFICATIONS

##### General

Make	John Deere 6068HFG04
EPA Emissions Compliance	Tier IV Final
Aftertreatment System	SCR / DOC
Cylinder #	6
Type	In-line
Displacement	415 in <sup>3</sup> (6.8L)
Bore – in (mm)	4.17 (106)
Stroke – in (mm)	5.0 (127.0)
Compression Ratio	17.2:1
Intake Air Method	Turbocharged + Aftercooled

##### Engine Governing

Governor	Electronic
Frequency Regulation (Steady State)	2%

##### Lubrication System

Oil Pump Type	Gear
Oil Filter Type	Spin-on cartridge
Crankcase Capacity – qts (L)	34.3 (32.5)

##### Cooling System

Cooling System Type	Pressurized closed
Water Pump Type	Belt driven
Fan Type	Pusher
Fan Speed (rpm)	2190
Fan Diameter – in (mm)	27.9 (710)
Coolant System Capacity – gal (L)	11 (42)

##### Fuel System

Fuel Type	Ultra low sulfur diesel
Fuel Specifications	EN 590 / ASTM D975
Fuel Filtering (microns)	2
Fuel Inject Pump Make	Denso HP6
Fuel Pump Type	Engine driven – belt
Injector Type	Electronic
Engine Type	Direct inject
Fuel Supply Line – in (mm)	0.375 (9.5)
Fuel Return Line – in (mm)	0.375 (9.5)

##### Engine Electrical System

System Voltage	12VDC
Battery Charger Alternator	STD
Battery Size	1000 CCA
Battery Voltage	12VDC (2)
Ground Polarity	Negative

#### ALTERNATOR SPECIFICATIONS

Standard Model	431CSL6208
Poles	4
Field Type	Rotating
Insulation Class – Rotor	H
Insulation Class – Stator	H
Total Harmonic Distortion	< 5%
Telephone Interference Factor (TIF)	< 50

Standard Excitation	Brushless
Bearings	Double shielded, pre-lubricated
Coupling	Direct, flexible disc
Prototype Short Circuit Test	Yes
Voltage Regulator Type	AVR
Number of Sensed Phases	1
Regulation Accuracy (Steady State)	± 1%

**MDG150DF4 | 6.8L | 120 kW****MOBILE DIESEL GENERATOR SET**

EPA Emissions Certification: Tier IV Final

**GENERAC®****MAGNUM****OPERATING DATA****POWER RATINGS**

	Standby		Prime	
Single-phase 120/240VAC @ 1.0pf (kW/kVA)	114 kW / 114 kVA	Amps: 473	108 kW / 180 kVA	Amps: 450
Three-phase 120/208VAC @ 0.8pf (kW/kVA)	144 kW / 180 kVA	Amps: 503	120 kW / 150 kVA	Amps: 416
Three-phase 120/240VAC @ 0.8pf (kW/kVA)	144 kW / 180 kVA	Amps: 433	120 kW / 150 kVA	Amps: 360
Three-phase 277/480VAC @ 0.8pf (kW/kVA)	144 kW / 180 kVA	Amps: 218	120 kW / 150 kVA	Amps: 180

**STARTING CAPABILITIES (sKVA)**

	sKVA vs. Voltage Dip	
	208 VAC	480 VAC
SuperStart	23%	21%

**FUEL CONSUMPTION RATES\***

Percent Load	Diesel – gal/hr (l/hr)	
	Standby	Prime
25%	3.6 (13.6)	3.4 (12.9)
50%	5.8 (22.0)	5.25 (19.9)
75%	7.8 (29.5)	7.1 (26.9)
100%	9.5 (36.0)	8.7 (33.0)

Deration – Operational characteristics consider maximum ambient conditions. Derate factors may apply under atypical site conditions.

Please consult a Generac Mobile Products Authorized Service Dealer for additional details. All performance ratings in accordance with ISO3046, BS5514, ISO8528, ISO8665, ISO3046, SAE J1228, SAE J1995, and DIN6271 standards.

**MDG150DF4 | 6.8L | 120 kW**

**MOBILE DIESEL GENERATOR SET**

EPA Emissions Certification: Tier IV Final

**GENERAC®**

**MAGNUM**

**DIMENSIONS AND WEIGHTS\***

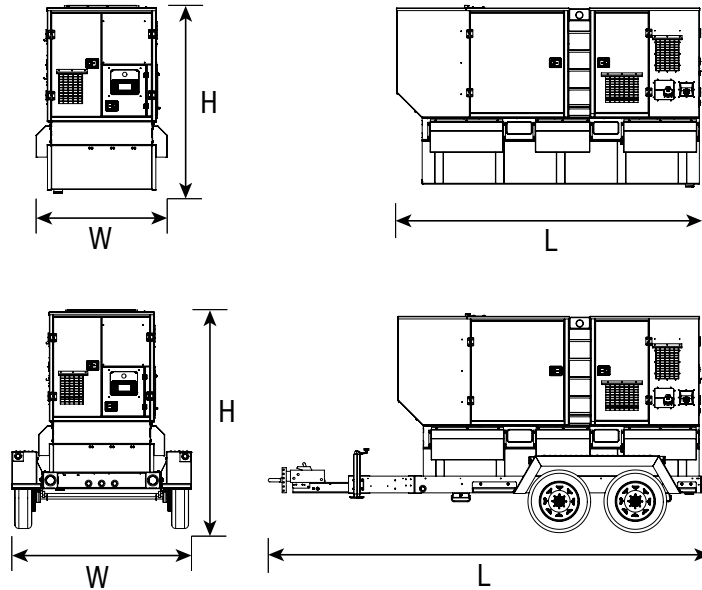

	Run Time Hours	Usable Capacity Gal (L)	L x W x H in (m)	Weight lbs (kg)
Skid	39	343 (1297)	145 (3.7) x 60 (1.5) x 85 (2.1)	Dry: 8770 (3978) Operating: 11590 (5257)
Trailer	39	343 (1297)	208 (5.3) x 86 (2.2) x 104 (2.6)	Dry: 10170 (4613) Operating: 12990 (5892)

\* All measurements are approximate and for estimation purposes only.

**YOUR FACTORY RECOGNIZED GENERAC MOBILE PRODUCTS DEALER**

Specification characteristics may change without notice. Dimensions and weights are for preliminary purposes only. Please consult a Generac Mobile Products Authorized Service Dealer for detailed installation drawings.