

CONCRETE (HURRICANE) PADS (GENPADs) FOR GENERAC GENERATORS

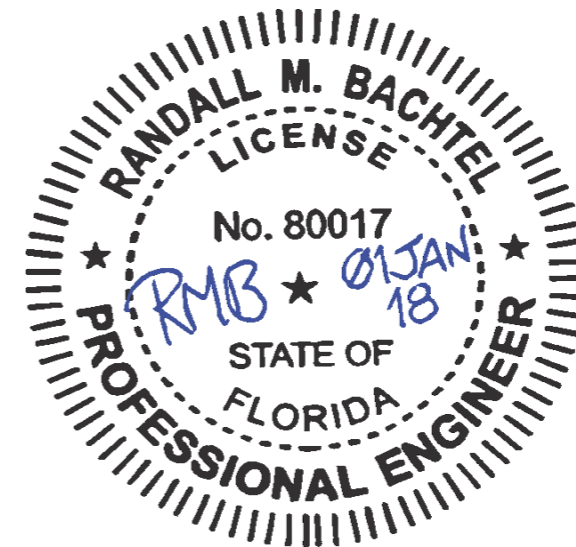

DiversiTech Corporation
 6650 Sugarloaf Parkway #100
 Duluth, GA 30097
 (800) 397-4823

Randall M. Bachtel, P.E. FL P.E. # 80017
RMB ENGINEERING LLC
 2346 Lake Ridge Terrace Phone (770) 713-0823
 Lawrenceville, GA 30043 Mobile (770) 713-6464



IMPORTANT NOTE: EACH ROW IN THE TABLE BELOW IS GOVERNED BY THE EQUIPMENT MAX. DIMENSIONS AND MIN. WEIGHT ONLY. GENERATOR CAPACITY (kW) AND MODEL NUMBERS (Pg-3) ARE REFERENCES ONLY.

LIMITS & REQUIREMENTS OF USE:

- 1) THE PAD AND THE SUPPORTED EQUIPMENT MUST BE LOCATED AT GROUND LEVEL. THIS TABLE DOES NOT APPLY TO ROOFTOP EQUIPMENT, EQUIPMENT LOCATED ON BALCONIES, OR ANY OTHER EQUIPMENT TO BE ELEVATED ABOVE GROUND LEVEL. FOR PADS TO BE INSTALLED OTHER THAN AT GROUND LEVEL PLEASE CONTACT (RMB) RMB ENGINEERING TO OBTAIN A CUSTOM WIND TABLE TO MEET YOUR SPECIFIC APPLICATION. MINIMUM SOIL COEFFICIENT OF FRICTION = 0.25 AS VERIFIED BY OTHERS.
- 2) THE AREA UNDER CONCRETE SLAB ON GROUND SHALL HAVE ALL MATERIALS REMOVED PRIOR TO INSTALLATION ON COMPACTED SOIL AS VERIFIED BY OTHERS.
- 3) MAXIMUM DIMENSIONS AND WEIGHT OF GENERATORS UNIT SHALL CONFORM TO SPECIFICATIONS STATED HEREIN. PAD WEIGHT TO BE VERIFIED BY OTHERS.
- 4) ORIGINAL EQUIPMENT MANUFACTURER INSTALLATION INSTRUCTIONS SUPERSEDE HURRICANE PAD INSTALLATION INSTRUCTIONS IF MORE STRINGENT.
- 5) ELECTRICAL GROUND, WHEN REQUIRED, TO BE DESIGNED & INSTALLED BY OTHERS. ALL MECHANICAL SPECIFICATIONS (CLEAR SPACE, TONNAGE, ETC.) SHALL BE AS PER MANUFACTURER RECOMMENDATIONS AND ARE THE EXPRESS RESPONSIBILITY OF THE CONTRACTOR.
- 6) ENGINEER SEAL AFFIXED HERETO VALIDATES STRUCTURAL DESIGN AS SHOWN ONLY. USE OF THIS SPECIFICATION BY CONTRACTOR, et. al. INDEMNIFIES & SAVES HARMLESS THIS ENGINEER FOR ALL COST & DAMAGES INCLUDING LEGAL FEES & APPELLATE FEES RESULTING FROM MATERIAL FABRICATION, SYSTEM ERECTION, CONSTRUCTION PRACTICES BEYOND THAT WHICH IS CALLED FOR BY LOCAL, STATE, & FEDERAL CODES & FROM DEVIATIONS OF THIS PLAN.
- 7) THE ROLE OF THIS ENGINEER FOR THIS PROJECT IS THAT OF SPECIALTY ENGINEER AND NOT THE ENGINEER OF RECORD. CONSEQUENTLY, THE ARCHITECT/ENGINEER OF RECORD SHALL BE RESPONSIBLE FOR THE INTEGRITY OF ALL SUPPORTING SURFACES TO THIS DESIGN WHICH SHALL BE COORDINATED BY THE PERMITTING CONTRACTOR.
- 8) ENGINEER SEAL AFFIXED HERETO VALIDATES STRUCTURAL DESIGN AS SHOWN ONLY. THIS DOCUMENT IS GENERIC & DOES NOT PERTAIN TO ANY SPECIFIC PROJECT SITE.
- 9) THIS ENGINEER SHALL NOT BE HELD RESPONSIBLE OR LIABLE IN ANY WAY FOR ERRONEOUS OR INACCURATE DATA OR MEASUREMENTS. DIMENSIONS ARE SHOWN TO ILLUSTRATE DESIGN FORCES AND OTHER DESIGN CRITERIA. THEY MAY VARY SLIGHTLY, BUT MUST REMAIN WITHIN THE LIMITATIONS SPECIFIED HEREIN.
- 10) THIS ENGINEER SHALL BE NOTIFIED AND GIVEN AN OPPORTUNITY TO RE-EVALUATE THIS WORK UPON DISCOVERY OF ANY INACCURATE INFORMATION PRIOR TO MODIFICATION OF EXISTING FIELD CONDITIONS AND FABRICATION AND INSTALLATION OF MATERIALS.
- 11) ALTERATIONS OR ADDITIONS TO THIS DOCUMENT ARE NOT PERMITTED AND INVALIDATE THIS CERTIFICATION.
- 12) EXCEPT AS EXPRESSLY PROVIDED HEREIN, NO ADDITIONAL CERTIFICATIONS OR AFFIRMATIONS ARE INTENDED.
- 13) PADS SHALL BE CONSTRUCTED WITH PRECAST CONCRETE, MINIMUM COMPRESSIVE STRENGTH, $f_c = 7,000$ PSI AT 28 DAYS.
- 14) ALL OTHER UNITS NOT SHOWN SHALL BE DESIGNED ON A CASE BY CASE BASIS AND ARE NOT COVERED BY THIS DOCUMENT.
- 15) CONTRACTOR SHALL PROVIDE 5/8" DIA. (0.675" O.D.) GALV. TUBE ASTM A53B SCH 40 MIN. OR 1/2" DIA. SOLID COPPER BAR SPIKE 4" MIN. EMBED. (SEE MIN. EMBED. AS PER CURRENT ELECTRICAL CODE, BY OTHERS) INTO GROUND THROUGH CONCRETE PAD FOR SLIDING RESISTANCE PURPOSE, 12 DIAMETERS EDGE DISTANCE (MIN.) FROM ANY CONCRETE FACE (NOT SHOWN).

ENGINEERING DATA:

- 1) WIND LOAD ANALYSES PER 6th EDITION (2017) FLORIDA BUILDING CODE - SECTION 1609 WIND LOADS - 1620 HIGH VELOCITY HURRICANE ZONES.
- 2) ALL STRUCTURES SHALL BE CONSIDERED TO BE IN EXPOSURE CAT. C, UNLESS EXPOSURE CAT. D APPLIES AS DEFINED IN SECTION 26.7 OF ASCE 7. EXPOSURE D SHALL EXTEND INLAND FROM ANY SHORELINE FOR A DISTANCE OF 600 FT OR 20 TIMES THE HEIGHT OF THE BUILDING, WHICHEVER IS GREATER.
- 3) WIND LOADS & LOAD COMBINATIONS PER ASCE 7-16 SECT. 2.4.1.7 (LOAD COMBINATIONS - ASD) & SECT. 29.5 & 2017 FBC SECT. 1605.3.1 BASIC LOAD COMBINATIONS & FIGURE 29.5.1: WIND LOADS ON OTHER STRUCTURES
- 4) RISK CATEGORY = II TABLE 1604.5 - RISK CATEGORY OF BUILDINGS AND OTHER STRUCTURES, SECTION 301.15 OF THE MECHANICAL CODE, WIND RESISTANCE, AND 553.844 OF THE FLORIDA STATUTES WIND STORM LOSS MITIGATION.
- 5) WIND LOAD:

Wind Speed V =	186	180	175	170	150	MPH
EXP C $qz = 0.00256 * Kz * Kzt * Kd * V^2 =$	67.75	63.45	59.98	56.60	44.06	EXP - C
$P = qz * G * Cf =$	80.63	75.51	71.37	67.35	52.44	PSF
EXP D $qz = 0.00256 * Kz * Kzt * Kd * V^2 =$	82.10	76.89	72.68	68.58	53.40	EXP - D
$P = qz * G * Cf =$	97.70	91.50	86.49	81.61	63.54	PSF
Exposure C ; Table 28.3-1 $Kz = 0.85$	Exposure D ; Table 28.3-1 $Kz = 1.03$					
Figure 26.8-1 $Kzt = 1.00$	ASCE 7-16 Fig 29.4-1 $Cf = 1.40$					
Table 26.6-1 $Kd = 0.90$	GUST FACTOR $G = 0.85$					

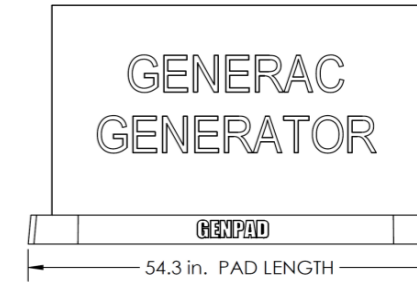
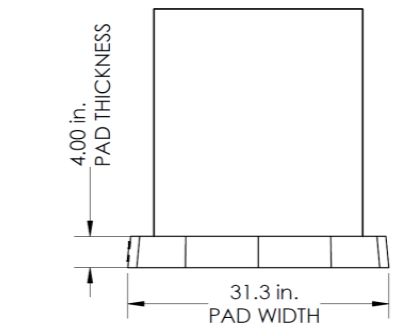

TYPICAL ANCHORAGE: (QTY=3)
 1/4" DIA. - 5 in long BOLTS, 3" MIN. EDGE DISTANCE, 1-3/8" EMBED. INTO CONCRETE (BASE PAN MIN. THICKNESS = 0.69" AND MIN. BEARING STRENGTH = 6 KSI)

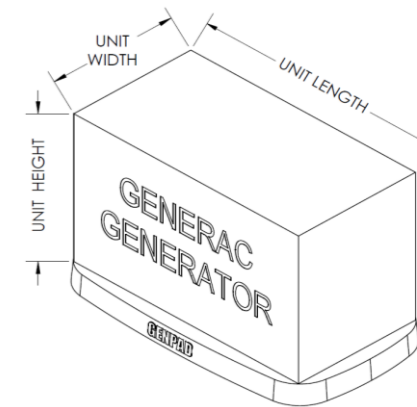
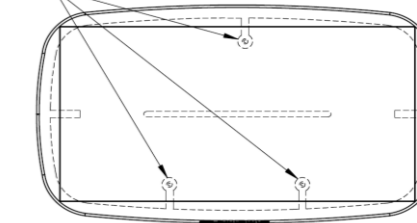

FG5431-4G (GENPAD) GRP A01-16

GENERAC GENERATORS		GEN CAP.	UNIT / EQUIPMENT				FG5431-4G PAD USED FOR GROUP A01-16				EXPOSURE C		EXPOSURE D		RESISTANCE		DESIGN CHECK EXPOSURE C		DESIGN CHECK EXPOSURE D				
SEE PG 3 OF 3 FOR GROUP DETAILS			MAXIMUM DIMENSIONS INCHES			MIN. WEIGHT	PAD MODEL	PAD WEIGHT	PAD WIDTH	PAD LENGTH	PAD THICK	WIND LOAD	WIND MOMENT	WIND LOAD	WIND MOMENT	UNIT+PAD WEIGHT	RESISTING MOMENT	OK FOR	MPH	OK FOR	MPH		
WIDTH	LENGTH		HEIGHT	LBS.	NUMBER	LBS.	IN.	IN.	IN.	LBS.	FT-LBS.	LBS.	FT-LBS.	LBS.	FT-LBS.								
GENERAC	GROUP - A01	8-9kW	25.1	47.9	28.6	341	FG5431-4G	275	31.3	54.3	4	591.4	803	591.4	803	616.0	803	OK FOR	163	MPH	OK FOR	148	MPH
GENERAC	GROUP - A02	10-11kW	25.1	47.9	28.6	348	FG5431-4G	275	31.3	54.3	4	598.2	812	598.2	812	623.0	812	OK FOR	164	MPH	OK FOR	149	MPH
GENERAC	GROUP - A03	10-11kW	25.1	47.9	28.6	389	FG5431-4G	275	31.3	54.3	4	637.5	866	637.5	866	664.0	866	OK FOR	170	MPH	OK FOR	154	MPH
GENERAC	GROUP - A04	16-17kW	25.1	47.9	28.6	409	FG5431-4G	275	31.3	54.3	4	656.7	892	656.7	892	684.0	892	OK FOR	172	MPH	OK FOR	156	MPH
GENERAC	GROUP - A05	16-17kW	25.1	47.9	28.6	419	FG5431-4G	275	31.3	54.3	4	666.3	905	666.3	905	694.0	905	OK FOR	173	MPH	OK FOR	157	MPH
GENERAC	GROUP - A06	16-17kW	25.1	47.9	28.6	421	FG5431-4G	275	31.3	54.3	4	668.2	908	668.2	908	696.0	908	OK FOR	174	MPH	OK FOR	158	MPH
GENERAC	GROUP - A07	13-14kW	25.1	47.9	28.6	425	FG5431-4G	275	31.3	54.3	4	672.1	913	672.1	913	700.0	913	OK FOR	174	MPH	OK FOR	158	MPH
GENERAC	GROUP - A08	13-14kW	25.1	47.9	28.6	439	FG5431-4G	275	31.3	54.3	4	685.5	931	685.5	931	714.0	931	OK FOR	176	MPH	OK FOR	160	MPH
GENERAC	GROUP - A09	16-22kW	25.1	47.9	28.6	448	FG5431-4G	275	31.3	54.3	4	694.2	943	694.2	943	723.0	943	OK FOR	177	MPH	OK FOR	161	MPH
GENERAC	GROUP - A10	20-22kW	25.1	47.9	28.6	451	FG5431-4G	275	31.3	54.3	4	697.0	947	697.0	947	726.0	947	OK FOR	177	MPH	OK FOR	161	MPH
GENERAC	GROUP - A11	16-17kW	25.1	47.9	28.6	455	FG5431-4G	275	31.3	54.3	4	700.9	952	700.9	952	730.0	952	OK FOR	178	MPH	OK FOR	162	MPH
GENERAC	GROUP - A12	20-22kW	25.1	47.9	28.6	466	FG5431-4G	275	31.3	54.3	4	711.5	966	711.5	966	741.0	966	OK FOR	179	MPH	OK FOR	163	MPH
GENERAC	GROUP - A13	17-20kW	25.1	47.9	28.6	471	FG5431-4G	275	31.3	54.3	4	716.3	973	716.3	973	746.0	973	OK FOR	180	MPH	OK FOR	163	MPH
GENERAC	GROUP - A14	20-22kW	25.1	47.9	28.6	476	FG5431-4G	275	31.3	54.3	4	721.1	979	721.1	979	751.0	979	OK FOR	180	MPH	OK FOR	164	MPH
GENERAC	GROUP - A15	20-22kW	25.1	47.9	28.6	505	FG5431-4G	275	31.3	54.3	4	748.9	1017	748.9	1017	780.0	1017	OK FOR	184	MPH	OK FOR	167	MPH
GENERAC	GROUP - A16	15-20kW	25.1	47.9	28.6	526	FG5431-4G	275	31.3	54.3	4	769.1	1045	769.1	1045	801.0	1045	OK FOR	186	MPH	OK FOR	169	MPH



DiversiTech Corporation
 6650 Sugarloaf Parkway #100
 Duluth, GA 30097
 (800) 397-4823

Randall M. Bachtel, P.E. FL P.E. # 80017
RMB ENGINEERING LLC
 2346 Lake Ridge Terrace Phone (770) 713-0823
 Lawrenceville, GA 30043 Mobile (770) 713-6464

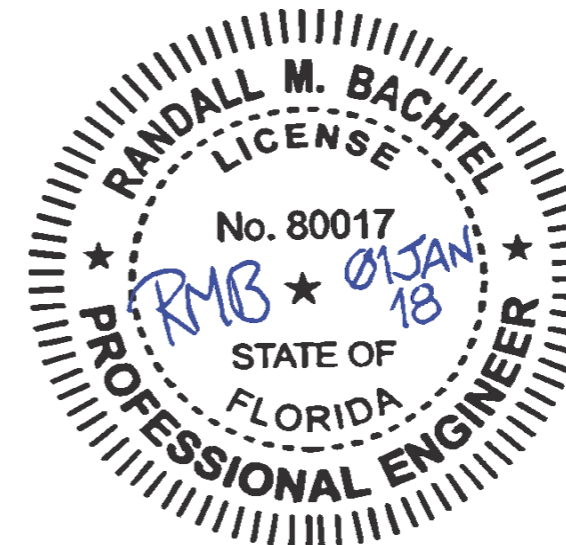

IMPORTANT NOTE: EACH ROW IN THE TABLE BELOW IS GOVERNED BY THE EQUIPMENT MAX. DIMENSIONS AND MIN. WEIGHT ONLY. GENERATOR CAPACITY (kW) AND MODEL NUMBERS (Pg-3) ARE REFERENCES ONLY.

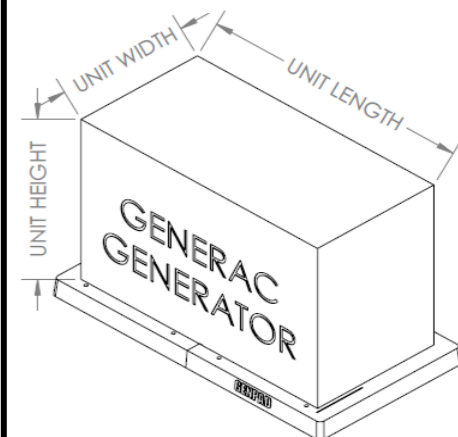
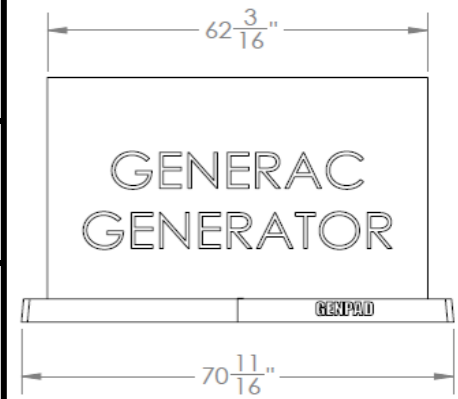
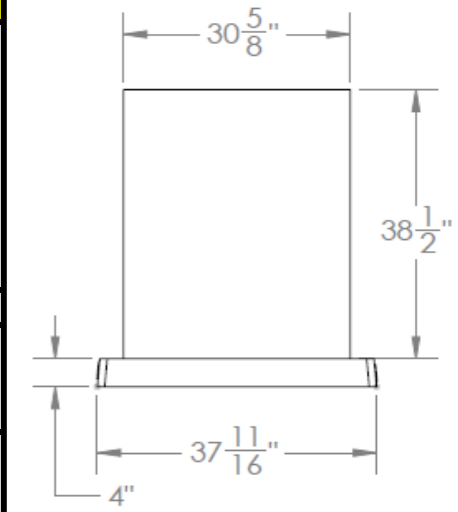

FG7037-4G (GENPAD) GRP B01-05

LIMITS & REQUIREMENTS OF USE:

- 1) THE PAD AND THE SUPPORTED EQUIPMENT MUST BE LOCATED AT GROUND LEVEL. THIS TABLE DOES NOT APPLY TO ROOFTOP EQUIPMENT, EQUIPMENT LOCATED ON BALCONIES, OR ANY OTHER EQUIPMENT TO BE ELEVATED ABOVE GROUND LEVEL. FOR PADS TO BE INSTALLED OTHER THAN AT GROUND LEVEL PLEASE CONTACT (RMB) RMB ENGINEERING TO OBTAIN A CUSTOM WIND TABLE TO MEET YOUR SPECIFIC APPLICATION. MINIMUM SOIL COEFFICIENT OF FRICTION = 0.25 AS VERIFIED BY OTHERS.
- 2) THE AREA UNDER CONCRETE SLAB ON GROUND SHALL HAVE ALL MATERIALS REMOVED PRIOR TO INSTALLATION ON COMPACTED SOIL AS VERIFIED BY OTHERS.
- 3) MAXIMUM DIMENSIONS AND WEIGHT OF GENERATORS UNIT SHALL CONFORM TO SPECIFICATIONS STATED HEREIN. PAD WEIGHT TO BE VERIFIED BY OTHERS.
- 4) ORIGINAL EQUIPMENT MANUFACTURER INSTALLATION INSTRUCTIONS SUPERSEDE HURRICANE PAD INSTALLATION INSTRUCTIONS IF MORE STRINGENT.
- 5) ELECTRICAL GROUND, WHEN REQUIRED, TO BE DESIGNED & INSTALLED BY OTHERS. ALL MECHANICAL SPECIFICATIONS (CLEAR SPACE, TONNAGE, ETC.) SHALL BE AS PER MANUFACTURER RECOMMENDATIONS AND ARE THE EXPRESS RESPONSIBILITY OF THE CONTRACTOR.
- 6) ENGINEER SEAL AFFIXED HERETO VALIDATES STRUCTURAL DESIGN AS SHOWN ONLY. USE OF THIS SPECIFICATION BY CONTRACTOR, et. al. INDEMNIFIES & SAVES HARMLESS THIS ENGINEER FOR ALL COST & DAMAGES INCLUDING LEGAL FEES & APPELLATE FEES RESULTING FROM MATERIAL FABRICATION, SYSTEM ERECTION, CONSTRUCTION PRACTICES BEYOND THAT WHICH IS CALLED FOR BY LOCAL, STATE, & FEDERAL CODES & FROM DEVIATIONS OF THIS PLAN.
- 7) THE ROLE OF THIS ENGINEER FOR THIS PROJECT IS THAT OF SPECIALTY ENGINEER AND NOT THE ENGINEER OF RECORD. CONSEQUENTLY, THE ARCHITECT/ENGINEER OF RECORD SHALL BE RESPONSIBLE FOR THE INTEGRITY OF ALL SUPPORTING SURFACES TO THIS DESIGN WHICH SHALL BE COORDINATED BY THE PERMITTING CONTRACTOR.
- 8) ENGINEER SEAL AFFIXED HERETO VALIDATES STRUCTURAL DESIGN AS SHOWN ONLY. THIS DOCUMENT IS GENERIC & DOES NOT PERTAIN TO ANY SPECIFIC PROJECT SITE.
- 9) THIS ENGINEER SHALL NOT BE HELD RESPONSIBLE OR LIABLE IN ANY WAY FOR ERRONEOUS OR INACCURATE DATA OR MEASUREMENTS. DIMENSIONS ARE SHOWN TO ILLUSTRATE DESIGN FORCES AND OTHER DESIGN CRITERIA. THEY MAY VARY SLIGHTLY, BUT MUST REMAIN WITHIN THE LIMITATIONS SPECIFIED HEREIN.
- 10) THIS ENGINEER SHALL BE NOTIFIED AND GIVEN AN OPPORTUNITY TO RE-EVALUATE THIS WORK UPON DISCOVERY OF ANY INACCURATE INFORMATION PRIOR TO MODIFICATION OF EXISTING FIELD CONDITIONS AND FABRICATION AND INSTALLATION OF MATERIALS.
- 11) ALTERATIONS OR ADDITIONS TO THIS DOCUMENT ARE NOT PERMITTED AND INVALIDATE THIS CERTIFICATION.
- 12) EXCEPT AS EXPRESSLY PROVIDED HEREIN, NO ADDITIONAL CERTIFICATIONS OR AFFIRMATIONS ARE INTENDED.
- 13) PADS SHALL BE CONSTRUCTED WITH PRECAST CONCRETE, MINIMUM COMPRESSIVE STRENGTH, $f_c = 7,000$ PSI AT 28 DAYS.
- 14) ALL OTHER UNITS NOT SHOWN SHALL BE DESIGNED ON A CASE BY CASE BASIS AND ARE NOT COVERED BY THIS DOCUMENT.
- 15) CONTRACTOR SHALL PROVIDE 5/8" DIA. (0.675" O.D.) GALV. TUBE ASTM A53B SCH 40 MIN. OR 1/2" DIA. SOLID COPPER BAR SPIKE 4' MIN. EMBED. (SEE MIN. EMBED. AS PER CURRENT ELECTRICAL CODE, BY OTHERS) INTO GROUND THROUGH CONCRETE PAD FOR SLIDING RESISTANCE PURPOSE, 12 DIAMETERS EDGE DISTANCE (MIN.) FROM ANY CONCRETE FACE (NOT SHOWN).

ENGINEERING DATA:

- 1) WIND LOAD ANALYSES PER 6th EDITION (2017) FLORIDA BUILDING CODE - SECTION 1609 WIND LOADS - 1620 HIGH VELOCITY HURRICANE ZONES.
- 2) ALL STRUCTURES SHALL BE CONSIDERED TO BE IN EXPOSURE CAT. C, UNLESS EXPOSURE CAT. D APPLIES AS DEFINED IN SECTION 26.7 OF ASCE 7. EXPOSURE D SHALL EXTEND INLAND FROM ANY SHORELINE FOR A DISTANCE OF 600 FT OR 20 TIMES THE HEIGHT OF THE BUILDING, WHICHEVER IS GREATER.
- 3) WIND LOADS & LOAD COMBINATIONS PER ASCE 7-16 SECT. 2.4.1.7 (LOAD COMBINATIONS - ASD) & SECT. 29.5 & 2017 FBC SECT. 1605.3.1 BASIC LOAD COMBINATIONS & FIGURE 29.5.1: WIND LOADS ON OTHER STRUCTURES
- 4) RISK CATEGORY = II TABLE 1604.5 - RISK CATEGORY OF BUILDINGS AND OTHER STRUCTURES. SECTION 301.15 OF THE MECHANICAL CODE, WIND RESISTANCE, AND 553.844 OF THE FLORIDA STATUTES WIND STORM LOSS MITIGATION.

Wind Speed V =	186	180	175	170	150	MPH
EXP C $qz = 0.00256 * Kz * Kzt * Kd * V^2 =$	67.75	63.45	59.98	56.60	44.06	EXP - C
$P = qz * G * Cf =$	80.63	75.51	71.37	67.35	52.44	PSF
EXP D $qz = 0.00256 * Kz * Kzt * Kd * V^2 =$	82.10	76.89	72.68	68.58	53.40	EXP - D
$P = qz * G * Cf =$	97.70	91.50	86.49	81.61	63.54	PSF
Exposure C ; Table 28.3-1 $Kz = 0.85$	Exposure D ; Table 28.3-1 $Kz = 1.03$					
Figure 26.8-1 $Kzt = 1.00$	ASCE 7-16 Fig 29.4-1 $Cf = 1.40$					
Table 26.6-1 $Kd = 0.90$	GUST FACTOR $G = 0.85$					

GENERAC GENERATORS		GEN CAP.	UNIT / EQUIPMENT				FG7037-4G PAD USED FOR GROUP B01-05					EXPOSURE C		EXPOSURE D		RESISTANCE		DESIGN CHECK EXPOSURE C			DESIGN CHECK EXPOSURE D		
SEE PG 3 OF 3 FOR GROUP DETAILS			MAXIMUM DIMENSIONS INCHES	MIN. WEIGHT LBS.	PAD MODEL NUMBER	PAD WEIGHT LBS.	PAD WIDTH IN.	PAD LENGTH IN.	PAD THICK IN.	WIND LOAD LBS.	WIND MOMENT FT-LBS.	WIND LOAD LBS.	WIND MOMENT FT-LBS.	UNIT+PAD WEIGHT LBS.	RESISTING MOMENT FT-LBS.	OK FOR	MPH	OK FOR	MPH	OK FOR	MPH		
WIDTH	LENGTH																					HEIGHT	
GENERAC	GROUP - B01	25 kW	30.6	62.2	38.5	777	FG7037-4G	350	37.0	70.0	4	981.2	1737	981.2	1737	1127.0	1737	OK FOR	159	MPH	OK FOR	145	MPH
GENERAC	GROUP - B02	22 kW	30.6	62.2	38.5	905	FG7037-4G	350	37.0	70.0	4	1092.6	1935	1092.6	1935	1255.0	1935	OK FOR	168	MPH	OK FOR	153	MPH
GENERAC	GROUP - B03	30 kW	30.6	62.2	38.5	935	FG7037-4G	350	37.0	70.0	4	1118.7	1981	1118.7	1981	1285.0	1981	OK FOR	170	MPH	OK FOR	154	MPH
GENERAC	GROUP - B04	27 kW	30.6	62.2	38.5	940	FG7037-4G	350	37.0	70.0	4	1123.1	1989	1123.1	1989	1290.0	1989	OK FOR	170	MPH	OK FOR	155	MPH
GENERAC	GROUP - B05 **	25-30kW	30.6	62.2	38.5	777	FG7037-4G	350	37.0	70.0	4	1320.0	2337	1320.0	2337	1127.0	2337	OK FOR	185	MPH	OK FOR	168	MPH

** GENERAC GENPAD GROUP - B05 REQUIRES THE FG7037-4G GENPAD FROM DIVERSITECH PLUS THE USE OF TWO (2) BULLET STYLE EARTH ANCHORS MOUNTED ON DIAGONAL CORNERS OF THE GENPAD.

GENERAC GENERATORS		GEN CAP.	UNIT / EQUIPMENT				FG8341-4G PAD USED FOR GROUP C01-04					EXPOSURE C		EXPOSURE D		RESISTANCE		DESIGN CHECK EXPOSURE C			DESIGN CHECK EXPOSURE D		
SEE PG 3 OF 3 FOR GROUP DETAILS			MAXIMUM DIMENSIONS INCHES	MIN. WEIGHT LBS.	PAD MODEL NUMBER	PAD WEIGHT LBS.	PAD WIDTH IN.	PAD LENGTH IN.	PAD THICK IN.	WIND LOAD LBS.	WIND MOMENT FT-LBS.	WIND LOAD LBS.	WIND MOMENT FT-LBS.	UNIT+PAD WEIGHT LBS.	RESISTING MOMENT FT-LBS.	OK FOR	MPH	OK FOR	MPH	OK FOR	MPH		
WIDTH	LENGTH																					HEIGHT	
GENERAC	GROUP - C01	32-36kW	35.0	76.8	46.1	1225	FG8341-4G	470	41.0	83.0	4	2417.6	5047	2417.6	5047	1695.0	2896	OK FOR	205	MPH	OK FOR	187	MPH
GENERAC	GROUP - C02	38-60kW	35.0	76.8	46.1	1235	FG5431-4G	470	41.0	83.0	4	2431.8	5076	2431.8	5076	1705.0	2913	OK FOR	206	MPH	OK FOR	187	MPH
GENERAC	GROUP - C03	45 kW	35.0	76.8	46.1	1260	FG5431-4G	470	41.0	83.0	4	2467.5	5151	2467.5	5151	1730.0	2955	OK FOR	208	MPH	OK FOR	189	MPH
GENERAC	GROUP - C04	48 kW	35.0	76.8	46.1	1555	FG5431-4G	470	41.0	83.0	4	2888.2	6029	2888.2	6029	2025.0	3459	OK FOR	225	MPH	OK FOR	204	MPH

CONCRETE (HURRICANE) PADS (GENPADs) FOR GENERAC GENERATORS

GROUP B01 SHALL CONTAIN THE FOLLOWING GENERAC MODELS.
OTHER MODELS MAY BE INCLUDED IF THEY ARE DIMENSIONALLY THE SAME AND WEIGH AT LEAST 777 LBS.
 RG02515ANAX RG02515GNAX RG02515JNAX RG02515ANSX RG02515GNSX RG02515JNSX RG025

GROUP B02 SHALL CONTAIN THE FOLLOWING GENERAC MODELS.
OTHER MODELS MAY BE INCLUDED IF THEY ARE DIMENSIONALLY THE SAME AND WEIGH AT LEAST 905 LBS.
 HG02224ANAX HG02224GNAX HG02224JNAX RG022

GROUP B03 SHALL CONTAIN THE FOLLOWING GENERAC MODELS.
OTHER MODELS MAY BE INCLUDED IF THEY ARE DIMENSIONALLY THE SAME AND WEIGH AT LEAST 935 LBS.
 RG03015ANAX RG03015ANSX RG03015GNAX RG03015GNSX RG03015JNAX RG03015JNSX RG030

GROUP B04 SHALL CONTAIN THE FOLLOWING GENERAC MODELS.
OTHER MODELS MAY BE INCLUDED IF THEY ARE DIMENSIONALLY THE SAME AND WEIGH AT LEAST 935 LBS.
 HG02724ANAX HG02724GNAX HG02724JNAX RG02724ANAX RG02724GNAX RG02724JNAX
 RG02724MNAX RG02724RNAX RG027

GROUP B05 ** ** SHALL CONTAIN ALL THE MODELS IN GROUPS B01 - B04. THE GENERATOR UNIT MUST WEIGH AT LEAST 777 LBS.

GROUP C01 SHALL CONTAIN THE FOLLOWING GENERAC MODELS.
OTHER MODELS MAY BE INCLUDED IF THEY ARE DIMENSIONALLY THE SAME AND WEIGH AT LEAST 1225 LBS.
 HG03224ANAX HG03224GNAX HG03224JNAX HG03224KNAX RG032 RG036

GROUP C02 SHALL CONTAIN THE FOLLOWING GENERAC MODELS.
OTHER MODELS MAY BE INCLUDED IF THEY ARE DIMENSIONALLY THE SAME AND WEIGH AT LEAST 1235 LBS.
 EG03824ANAX EG03824GNAX EG03824JNAX EG03824KNAX HG03824ANAX HG03824JNAX
 HG03824GNAX HG03824KNAX RG060 RG038

GROUP C03 SHALL CONTAIN THE FOLLOWING GENERAC MODELS. RG045
OTHER MODELS MAY BE INCLUDED IF THEY ARE DIMENSIONALLY THE SAME AND WEIGH AT LEAST 1260 LBS.

GROUP C04 SHALL CONTAIN THE FOLLOWING GENERAC MODELS.
OTHER MODELS MAY BE INCLUDED IF THEY ARE DIMENSIONALLY THE SAME AND WEIGH AT LEAST 1550 LBS. RG048
 EG04854ANAX EG04854GNAX EG04854JNAX EG04854KNAX HG04854ANAX HG04854GNAX HG04854JNAX
 EG04854ANAX EG04854GNAX EG04854JNAX EG04854KNAX HG04854ANAX HG04854GNAX HG04854KNAX

GROUP A01 SHALL CONTAIN THE FOLLOWING GENERAC MODELS.
OTHER MODELS MAY BE INCLUDED IF THEY ARE DIMENSIONALLY THE SAME AND WEIGH AT LEAST 341 LBS.
 005870-0 G007044-0 G007144 G007029-1 G007057-0
 005870-1 G007047-1 G007029-0 G007030-1

GROUP A02 SHALL CONTAIN THE FOLLOWING GENERAC MODELS.
OTHER MODELS MAY BE INCLUDED IF THEY ARE DIMENSIONALLY THE SAME AND WEIGH AT LEAST 348 LBS.
 G007031-1 G007032-1 G007033-1 G007058-0

GROUP A03 SHALL CONTAIN THE FOLLOWING GENERAC MODELS.
OTHER MODELS MAY BE INCLUDED IF THEY ARE DIMENSIONALLY THE SAME AND WEIGH AT LEAST 389 LBS.
 005871-0 005871-1 G007045-0 G007048-1 G007145

GROUP A04 SHALL CONTAIN THE FOLLOWING GENERAC MODELS.
OTHER MODELS MAY BE INCLUDED IF THEY ARE DIMENSIONALLY THE SAME AND WEIGH AT LEAST 409 LBS.
 G007035-1 G007036-1 G007037-1 G007059-0 G007059-1 G007141-1

GROUP A05 SHALL CONTAIN THE FOLLOWING GENERAC MODELS. 006721-1
OTHER MODELS MAY BE INCLUDED IF THEY ARE DIMENSIONALLY THE SAME AND WEIGH AT LEAST 419 LBS.

GROUP A06 SHALL CONTAIN THE FOLLOWING GENERAC MODELS. 005886-1 006053-1
OTHER MODELS MAY BE INCLUDED IF THEY ARE DIMENSIONALLY THE SAME AND WEIGH AT LEAST 421 LBS.

GROUP A07 SHALL CONTAIN THE FOLLOWING GENERAC MODELS. G007049-1 G007046-0 G007146
OTHER MODELS MAY BE INCLUDED IF THEY ARE DIMENSIONALLY THE SAME AND WEIGH AT LEAST 425 LBS.

GROUP A08 SHALL CONTAIN THE FOLLOWING GENERAC MODELS. 005872-0 005872-1
OTHER MODELS MAY BE INCLUDED IF THEY ARE DIMENSIONALLY THE SAME AND WEIGH AT LEAST 439 LBS.

Randall M. Bachtel, P.E. FL P.E. # 80017
RMB ENGINEERING LLC
 2346 Lake Ridge Terrace Phone (770) 713-0823
 Lawrenceville, GA 30043 Mobile (770) 713-6464



DiversiTech Corporation
 6650 Sugarloaf Parkway #100
 Duluth, GA 30097
 (800) 397-4823

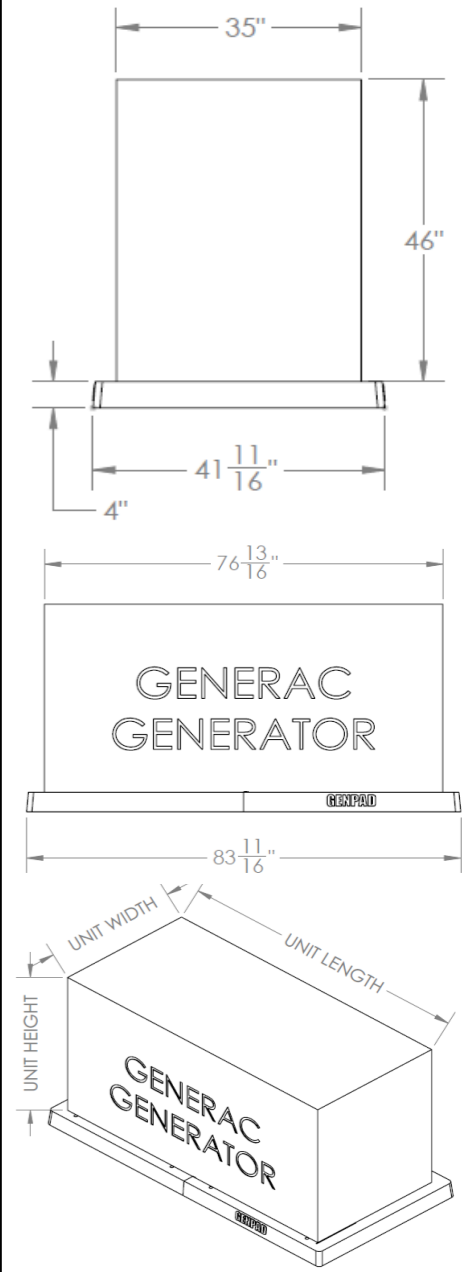
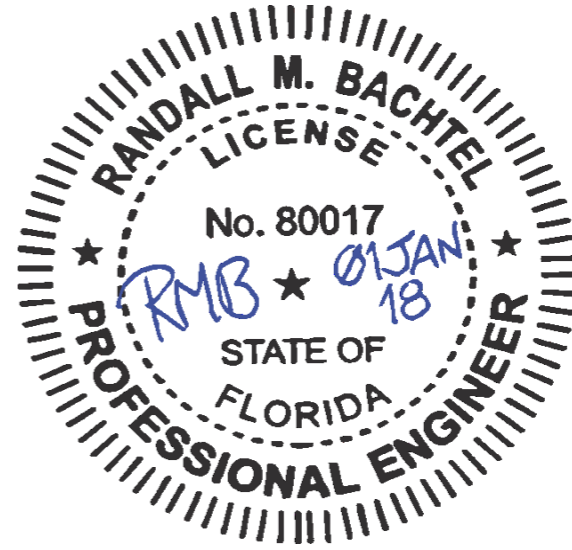

FG8341-4G (GENPAD) GRP C01-04

GROUP A09 SHALL CONTAIN THE FOLLOWING GENERAC MODELS.
OTHER MODELS MAY BE INCLUDED IF THEY ARE DIMENSIONALLY THE SAME AND WEIGH AT LEAST 448 LBS.
 G007038-1 G007062-0 G007042-2 70351
 G007039-1 G007062-1 G007043-2 G006459

GROUP A10 SHALL CONTAIN THE FOLLOWING GENERAC MODELS. 005875-1 005887-1
OTHER MODELS MAY BE INCLUDED IF THEY ARE DIMENSIONALLY THE SAME AND WEIGH AT LEAST 451 LBS.

GROUP A11 SHALL CONTAIN THE FOLLOWING GENERAC MODELS.
OTHER MODELS MAY BE INCLUDED IF THEY ARE DIMENSIONALLY THE SAME AND WEIGH AT LEAST 455 LBS.
 006459-2 006462-2 006461-1 005873-1 005885-1

GROUP A12 SHALL CONTAIN THE FOLLOWING GENERAC MODELS.
OTHER MODELS MAY BE INCLUDED IF THEY ARE DIMENSIONALLY THE SAME AND WEIGH AT LEAST 466 LBS.
 G007078-1 G007064-2 G007042-1 G007065-1 G007063-2 G007043-1
 G007142-1 G007077-0

GROUP A13 SHALL CONTAIN THE FOLLOWING GENERAC MODELS. G006260-0 G006282-0 G007040-0 G007041-0
OTHER MODELS MAY BE INCLUDED IF THEY ARE DIMENSIONALLY THE SAME AND WEIGH AT LEAST 471 LBS.

GROUP A14 SHALL CONTAIN THE FOLLOWING GENERAC MODELS. 006551-2 006552-1
OTHER MODELS MAY BE INCLUDED IF THEY ARE DIMENSIONALLY THE SAME AND WEIGH AT LEAST 476 LBS.

GROUP A15 SHALL CONTAIN THE FOLLOWING GENERAC MODELS. 006729-2 006730-1
OTHER MODELS MAY BE INCLUDED IF THEY ARE DIMENSIONALLY THE SAME AND WEIGH AT LEAST 505 LBS.

GROUP A16 SHALL CONTAIN THE FOLLOWING GENERAC MODELS. G007034-0
OTHER MODELS MAY BE INCLUDED IF THEY ARE DIMENSIONALLY THE SAME AND WEIGH AT LEAST 526 LBS.