

FIRMAN[®]

OPERATOR'S MANUAL GASOLINE PORTABLE GENERATOR

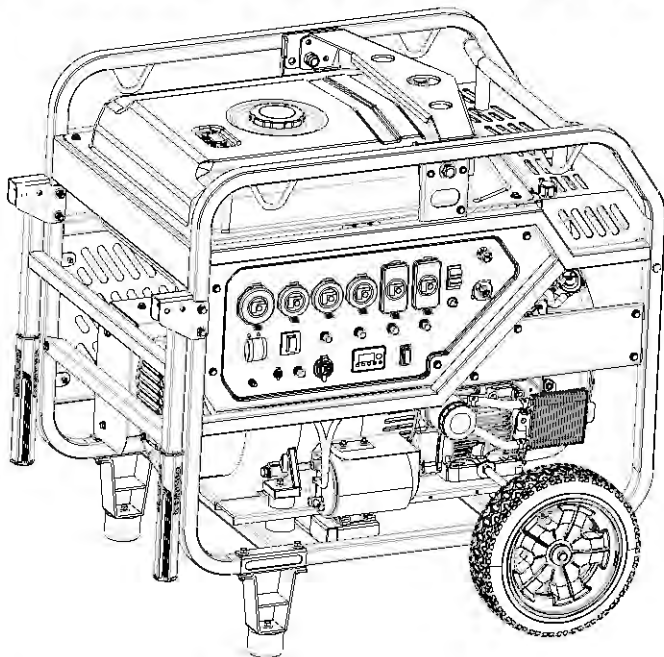

MODEL NUMBER
P12002

Rev Level:00

Record product information to reference when ordering parts or obtaining warranty coverage.

STOP DO NOT RETURN TO STORE!

CALL US FIRST
1-844-347-6261

FOR QUESTIONS OR SERVICE INFORMATION



SERIAL NUMBER: _____

PURCHASE DATE: _____

P/N:399745500 Rev:00

INTRODUCTION

Table of Contents

Introduction	1
Features and Controls	5
Operation	10
Maintenance - Storage	21
Troubleshooting- Specifications	28
Parts Diagrams - Parts Lists - Wiring Diagram	30
Service - Warranty	37

REGISTER YOUR PRODUCT

Register your Firman generator online at www.firmanpowerequipment.com



INTRODUCTION

Thank you for purchasing a FIRMAN generator. You have selected a high-quality, precision engineered generator set designed and tested to give you years of satisfactory service. This generator is designed to run only on unleaded gasoline. This generator is not intended to be run unattended or to supply power to life safety support.

This manual contains safety information to make you aware of the hazards and risks associated with generator products and how to avoid them. This generator is designed and intended only for supplying electrical power for operating compatible electrical lighting, appliances, tools and motor loads, and is not intended for any other purpose. It is important that you read and understand these instructions thoroughly before attempting to start or operate this portable generator. Save these original instructions for future reference.

All information in this publication is based on the latest production information available at the time of approval for printing. The manufacturer reserves the right to change, alter or otherwise improve the generator and this documentation at any time without prior notice.

SIGNAL WORDS

 DANGER	 WARNING	 CAUTION	NOTICE
Indicates a hazard which, if not avoided, will result in death or serious injury.	Indicates a hazard which, if not avoided, could result in death or serious injury.	Indicates a hazard which, if not avoided, could result in minor or moderate injury.	Indicates information considered Important, but not hazard-related.



Safety Alert Symbol- Indicates a potential personal injury hazard.



Operator's Manual- Failure to follow warnings, instructions and operator's manual could result in death or serious injury.



Toxic Fumes- Engine exhaust contains carbon monoxide, a poisonous gas that will kill you in minutes. You cannot smell it or see it.



Generator could cause electrical shock resulting in death or serious injury.



Fire- Fuel and its vapors are extremely flammable which could cause burns or fire resulting in death or serious injury. Engine exhaust could cause fire resulting in death or serious injury.



Hot Surface- Muffler could cause burns resulting in serious injury.

INTRODUCTION



WARNING! This product can expose you to chemicals including gasoline engine exhaust, which is known to the State of California to cause cancer, and carbon monoxide, which is known to the State of California to cause birth defects or other reproductive harm. For more information go to www.P65Warnings.ca.gov.

This outdoor generator can be used to power outdoor items using extension cords or to restore home power using a transfer switch. A transfer switch is a separate device installed by a licensed electrician that allows the portable generator to be cord connected, using either of the 120/240V receptacles, directly into your home's electrical system. Install a listed transfer switch as soon as possible if this generator will be used to restore power to your home.

NOTICE If you have questions about intended use, contact FIRMAN customer service. This portable generator is designed to be used only with FIRMAN authorized parts.

System Ground

The generator has a system ground that connects the generator frame components to the ground terminals on the AC output receptacles. The system ground is connected to the AC neutral wire. The neutral is bonded to the generator frame.

Compliance Requirements

There may be Federal or State regulations, local codes, or ordinances that apply to the intended use of the generator. Consult a qualified electrician, electrical inspector, or the local agency having jurisdiction. This generator is not intended to be used at a construction site or similar activity as defined by NFPA 70-2020 (NEC) section 590.6.

To Restore Home Power Using a Listed Transfer Switch

Connections to your home's electrical system must use a listed* transfer switch installed by a licensed electrician. The connection must isolate the generator power from the utility power and comply with all applicable laws and electrical codes.

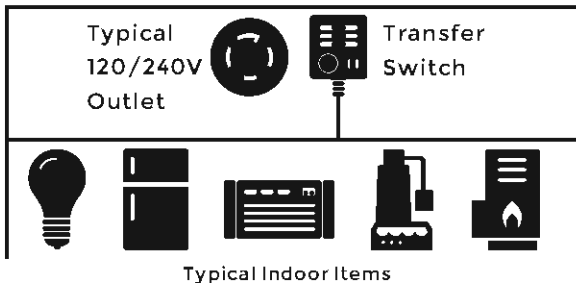

To Restore Power Using Extension Cords

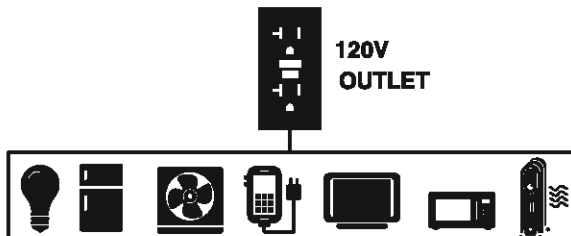

1. Only use grounded cords marked for outdoor use rated for your loads.

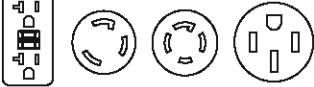
 To provide power using extension cords	
Total Amperage	Minimum Gauge, Outdoor Rated
	Up to 50 FT (15m)
Up to 13A	16
Up to 15A	14
Up to 20A	12
Up to 30A	10
Up to 50A	6

2. Follow cord safety instructions.

3. Install carbon monoxide alarm(s).

4. When operating portable generator with extension cords, make sure portable generator is located in an open, outdoor area, at least 20 ft. (6 m.) from occupied spaces with exhaust pointed away.

5. Extension cords running directly into your home, powering indoor items IS NOT RECOMMENDED.



DANGER! Engine exhaust contains carbon monoxide, a poisonous gas that will kill you in minutes. You cannot smell it, see it, or taste it. Even if you do not smell exhaust fumes, you could still be exposed to carbon monoxide gas.

- Extension cords running directly into the home increase your risk of carbon monoxide poisoning through any openings.
- If an extension cord running directly into your home is used to power indoor items, the operator recognizes that this increases the risk of CO poisoning to people inside the home and assumes that risk.

6. Install a listed *transfer switch as soon as possible if this or any generator will be used to restore power to your home.

*Certified by a Nationally Recognized Testing Laboratory that the product complies to appropriate product safety test standards.

FEATURES AND CONTROLS

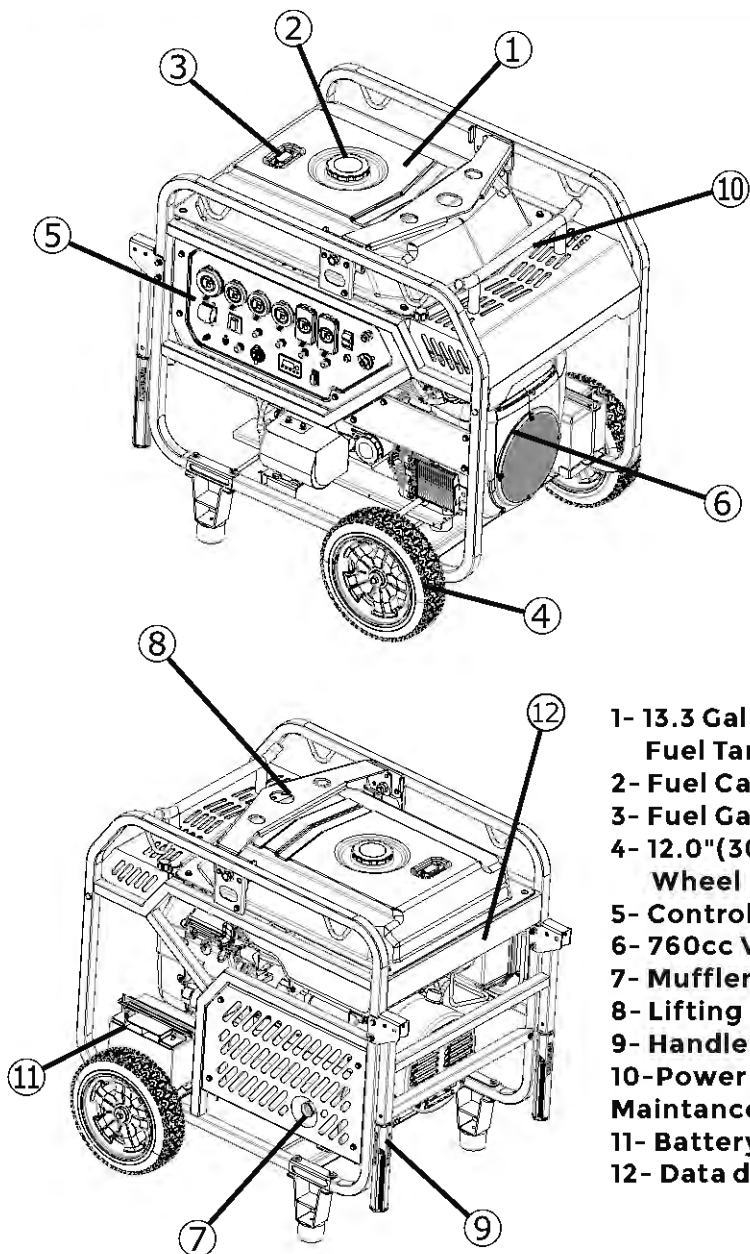

- 1- 13.3 Gallon(50.2L) Capacity Fuel Tank
- 2- Fuel Cap
- 3- Fuel Gauge
- 4- 12.0"(30.5cm) Flat Free Wheel
- 5- Control Panel
- 6- 760cc V-TWIN Engine
- 7- Muffler & Spark Arrester
- 8- Lifting Hook
- 9- Handle
- 10- Power Cord Holder & Maintenance cover handle
- 11- Battery
- 12- Data decal/ serial number

*We are always working to improve our products. Therefore, the enclosed product may differ slightly from the image on this page.

FEATURES AND CONTROLS

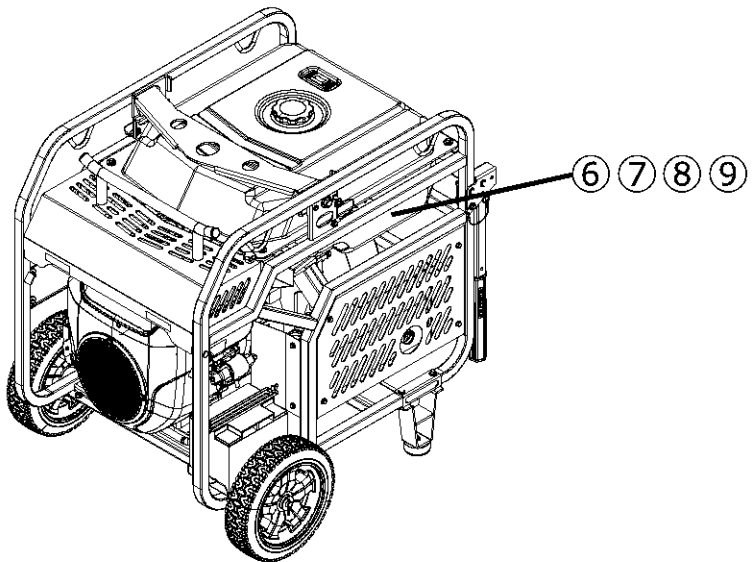
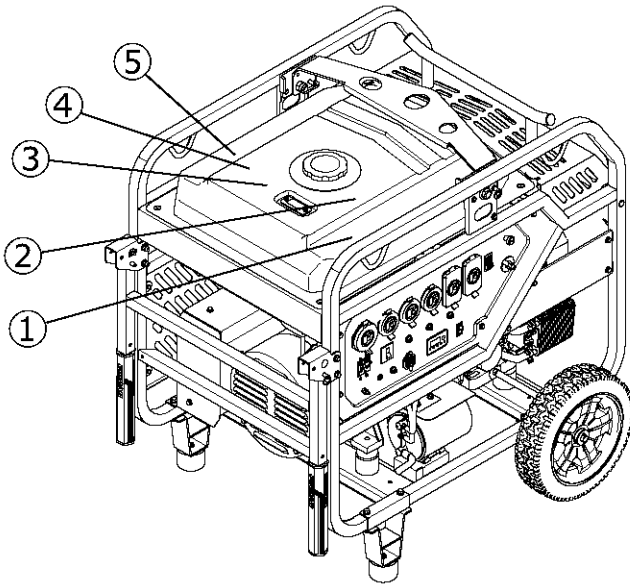

FEATURES AND CONTROLS

①

⚠ DANGER	⚠ PELIGRO	⚠ DANGER
Using a generator indoors CAN KILL YOU IN MINUTES. Generator exhaust contains carbon monoxide. This is a poison you cannot see or smell.	Utilizar un generador en interiores PUEDE PROVOCARLA MUERTE EN CUESTIÓN DE MINUTOS. Los gases del generador contienen monóxido de carbono, el cual es una sustancia venenosa que no puede verse ni olerse.	Utiliser un générateur à l'intérieur PEUT VOUS TUER EN QUELQUES MINUTES. Les gaz d'échappement du générateur contiennent du monoxyde de carbone. Ceci est un poison que vous ne pouvez ni voir ni sentir.
NEVER use inside a home or garage, EVEN IF doors and windows are open.		
Only use OUTSIDE and far away from windows, doors, and vents.	No utilice NUNCA el generador en el interior de su hogar ni en su garaje. NI SIQUERA con las puertas y ventanas abiertas.	NE JAMAIS utiliser dans un garage ou à l'intérieur, MÊME avec les portes et les fenêtres ouvertes.
À n'utiliser qu'à l'EXTÉRIEUR et à distance de toutes fenêtres, portes et ouvertures.	Utilice sólo AL AIRE LIBRE y lejos de ventanas, puertas y orificios de ventilación.	NE JAMAIS utiliser dans un garage ou à l'intérieur, MÊME avec les portes et les fenêtres ouvertes.

②

NOTICE	AVISO	AVIS
 	Operar, almacenar y transportar en una superficie firme y nivelada. <ul style="list-style-type: none"> • Inclinarlo puede causar un derrame de combustible. 	Faire fonctionner, entreposer et transporter sur une surface ferme et horizontale. <ul style="list-style-type: none"> • L'inclinaison peut causer un déversement de carburant.
Operate, store and transport on firm level surface. <ul style="list-style-type: none"> • Tilting can cause fuel spillage. 	Operar, almacenar y transportar en una superficie firme y nivelada. <ul style="list-style-type: none"> • Inclinarlo puede causar un derrame de combustible. 	Faire fonctionner, entreposer et transporter sur une surface ferme et horizontale. <ul style="list-style-type: none"> • L'inclinaison peut causer un déversement de carburant.

③ ④

⚠ DANGER	⚠ PELIGRO	⚠ DANGER
Failure to follow warnings, instructions and operator's manual could result in death or serious injury.	El incumplimiento de las advertencias, las instrucciones y el manual del operador podría provocar la muerte o lesiones graves.	Le non-respect des avertissements, des instructions et du manuel de l'utilisateur peut entraîner la mort ou des blessures graves.
Tampering with the CO ALERT system will cause Carbon Monoxide poisoning. Install Carbon Monoxide alarms inside home.	La alteración del sistema de alerta de CO causará envenenamiento por monóxido de carbono. Instale detectores de Monóxido de Carbono dentro de su casa.	Toute altération du système D'ALERTÉ du monoxyde de carbone causera un empoisonnement au monoxyde de carbone. Installez des détecteurs de monoxyde de carbone à l'intérieur de la maison.
Generator could cause electrical shock. Do not run indoors to avoid wet conditions. Do not run in rain or wet weather. Generator switch must be used when connecting to a home's electrical system.	El generador podría producir una descarga eléctrica. No utilice en interiores para evitar condiciones de humedad. No utilice en la lluvia o en condiciones de humedad. Es necesario usar un interruptor de transferencia cuando se conecta al sistema eléctrico de una casa.	Le générateur pourrait provoquer un choc électrique. Ne faites pas fonctionner à l'intérieur pour éviter les conditions humides. Ne faites pas fonctionner sous la pluie ou par temps pluvieux. Un commutateur de transfert doit être utilisé lors du raccordement au système électrique d'une maison.
Hot exhaust gases could cause fires. Keep at least 5ft. (1.5m) clearance from any combustibles or structures, including overhead.	Los gases calientes de salida podrían causar incendios. Manténgalos a una distancia mínima de 1,5m de cualquier combustible o estructura, incluyendo techos elevados.	Les gaz d'échappement chauds peuvent provoquer des incendies. Gardez au moins 5 pi (1,5 m) de dégagement de tout combustible ou de toute structure, y compris au-dessus.
Fuel level indicator Indicador de nivel de combustible Indicateur de niveau de carburant	WARNING Fuel is flammable which could cause burns resulting in death or serious injury. - Turn engine off and let it cool at least 2 minutes before refueling. - Do not fill fuel above fuel level indicator. - Never add fuel to a hot or running generator.	
ATENCIÓN El combustible es inflamable, lo que podría causar quemaduras resultantes en la muerte o lesiones graves. - Apague el motor y déjelo enfriar al menos 2 minutos antes de recargar combustible. - No llene el combustible por encima del indicador de nivel. - No cargue nunca combustible en un generador caliente o en funcionamiento.		
ATTENTION Le carburant est inflammable, ce qui peut provoquer des brûlures entraînant la mort ou des blessures graves. - Éteignez le moteur et le laissez refroidir au moins 2 minutes avant le remplissage. - Ne pas remplir au-delà de l'indicateur de niveau maximal de carburant. - Ne jamais ajouter de carburant à une génératrice chaude ou en marche.		

5

 AUTOMATIC SHUTOFF - YOU MUST:	 CORTE AUTOMÁTICO-DEBE REALIZAR LO SIGUIENTE:	 ARRÊT AUTOMATIQUE - VOUS DEVEZ:
 <p>20 FT. (6 m) MIN.</p>	<p>MOVE GENERATOR TO AN OPEN, OUTDOOR AREA. POINT EXHAUST AWAY FROM HOMES. DON'T RUN GENERATOR IN ENCLOSED AREAS (e.g. NOT IN HOUSE OR GARAGE). AIR OUT PREMISES (OPEN WINDOWS AND DOORS) BEFORE REOCCUPYING PROPERTY.</p>	<p>MUEVA EL GENERADOR A UN ÁREA ABIERTA AL AIRE LIBRE. APUNTE EL ESCAPE LEJOS DE LAS CASAS. NO UTILICE EL GENERADOR EN ÁREAS CERRADAS (EN CASA O EL GARAJE). VENTILE LAS INSTALACIONES (VENTANAS Y PUERTAS ABIERTAS) ANTES DE VOLVER A OCUPAR LA PROPIEDAD.</p>
	<p>MOVE TO FRESH AIR AND GET MEDICAL HELP IF SICK, DIZZY OR WEAK.</p>	<p>UBÍQUESE EN UN LUGAR DONDE CORRA AIRE FRESCO Y BUSQUE AYUDA MÉDICA SI SE SIENTE MAL, MALEADO O DÉBIL.</p>

6

FOR RESIDENTS OF CALIFORNIA	PARA LOS RESIDENTES DE CALIFORNIA	POUR LES RÉSIDENTS DE LA CALIFORNIE
<p>WARNING: This product and the engine exhaust from this product can expose you to chemicals including CO, which are known to the State of California to cause cancer or cause birth defects and other reproductive harm. For more information, go to www.P65Warnings.ca.gov.</p>	<p>ADVERTENCIA: Este producto y el escape del motor de este producto pueden exponerlo a productos químicos, incluido CO, que en el estado de California son conocidos por causar cáncer o causar defectos de nacimiento u otros daños reproductivos. Para obtener más información, vaya a www.P65Warnings.ca.gov.</p>	<p>AVERTISSEMENT: Ce produit et l'échappement du moteur de ce produit peuvent vous exposer à des produits chimiques, y compris le CO, qui sont connus par l'État de Californie pour causer le cancer ou causer des malformations congénitales et autres problèmes de reproduction. Pour plus d'informations, visitez www.P65Warnings.ca.gov.</p>

7

	WARNING	ADVERTENCIA	AVERTISSEMENT
	<p>Muffler could cause burns resulting in serious injury. •Do not touch hot parts •Avoid hot exhaust gases</p>	<p>El silenciador podría causar quemaduras resultando en una lesión grave. •No toque las partes calientes •Evite los gases de escape calientes</p>	<p>Le silencieux peut causer des brûlures et des blessures graves. • Ne pas toucher aux pièces chaudes. •Évitez les gaz d'échappement chauds.</p>

8

NOTICE	AVISO	AVIS
<p>To prevent engine damage the spark arrester should be cleaned every 100 hours. See Operator's manual.</p>	<p>Para evitar daños en el motor, el supresor de chispas debe limpiarse cada 100 horas. Consulte el manual del operador.</p>	<p>Pour éviter d'endommager le moteur, le pare-étincelles doit être nettoyé toutes les 100 heures. Consulter le manuel d'utilisation.</p>

9

<p>Point engine exhaust away from all occupied structures.</p>	<p>Mantenga los gases de escape del motor lejos de instalaciones ocupadas.</p>	<p>Pointer l'échappement du moteur loin de toutes les structures occupées.</p>
--	--	--

FEATURES AND CONTROLS

Control Panel

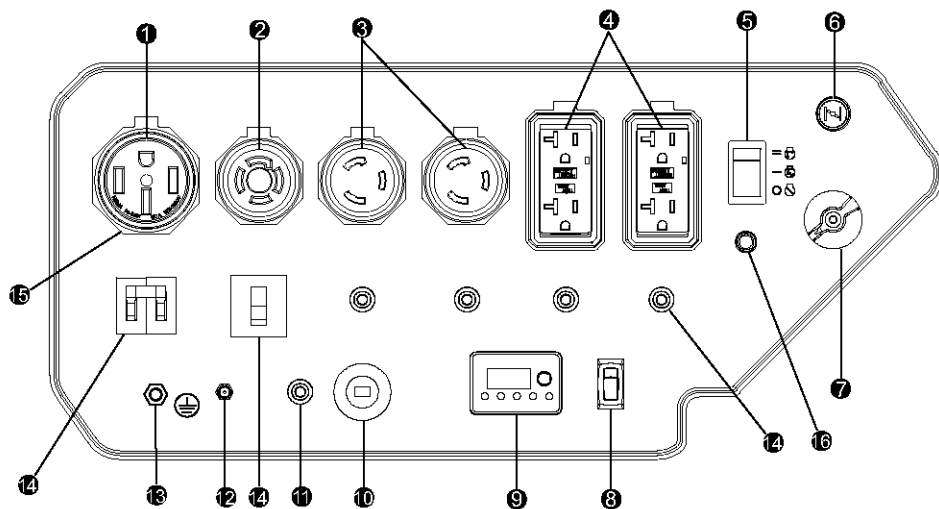

NOTICE Total power drawn from all receptacles must not exceed the name plate rating.

1. **120/240V, 50A - (NEMA 14-50R) (Not GFCI protected)**

Maximum full load current may be drawn from this 120/240 Volt, 50 Amp receptacle.

2. **120/240V, 30A Twist Lock - (NEMA L14-30R) (Not GFCI protected)**

A maximum of 30 Amps current for 240 Volts or two independent 120 Volt loads at 30 Amps current each.

3. **120V, 30A Twist Lock - NEMA L5-30R (Not GFCI protected)**

A maximum of 30 Amps current may be drawn from this receptacle.

4. **120V, 20A Duplex GFCI (Ground Fault Circuit Interrupter)- NEMA 5-20R**

A maximum of 20 Amps current may be drawn from this duplex receptacle.

5. **Engine Start Switch** - To start engine, press and hold the switch in the START (II) position, the engine will crank and attempt to start. When the engine starts, release the switch to the RUN (I) position.

6. **Choke Knob**

7. **Fuel Valve Knob**

8. **Economy Control Switch**

The Economy Control switch can be activated in order to minimize fuel consumption and noise while operating the unit during times of no electrical output, allowing the engine speed to idle during periods of no electrical usage. The engine speed returns to normal when an electrical load is connected. When the economy switch is off, the engine runs at normal speed continuously.

9. **4-1 Data-Minder (Multi-Meter)** - Push the SELECT button to show the Voltage, Hertz, running hours and low oil alarm.

10. **12V DC Outlet** - 8.3 Amp of DC current may be drawn from this receptacle.

Use this outlet to charge 12V automotive type batteries ONLY. See 12V DC outlet (Battery Charger) section.

11. **DC Circuit Breaker** - The circuit protector may be reset by pushing the button of the protector.

12. **12V DC Battery Charger Port** - Plug the 120 Volt AC charger into this port to charge the generator battery.

13. **Ground Terminal** - Consult an electrician or authority having jurisdiction for local grounding requirements.

14. Circuit Breakers - The receptacles are protected by AC circuit protectors. If the generator is overloaded or an external short circuit occurs, a circuit protector may trip. If tripping occurs, disconnect all electrical loads and determine the cause before attempting to continue using the generator. Reset any tripped circuit protectors.

If multiple receptacles are used at the same time, the total current must be kept with-in the portable generator data decal rating.

15. Outlet Cover - Protect the receptacles from dust and debris.

16. CO Alert™ Carbon Monoxide (CO) Shutdown Indicator Light – Indicates the engine shutdown due to carbon monoxide accumulation around the generator or a CO Alert system fault occurred.

1. Location



DANGER! Engine exhaust contains carbon monoxide, a poisonous gas that could kill you in minutes. You CANNOT smell it, see it, or taste it. Even if you do not smell exhaust fumes, you could still be exposed to carbon monoxide gas.

- Operate portable generator only outdoors, at least 20 ft. from occupied spaces with exhaust pointed away to reduce the risk of carbon monoxide accumulating.
- Install battery-operated carbon monoxide alarms or plug-in carbon monoxide alarms with battery back-up according to the manufacturer's instructions. Smoke alarms cannot detect carbon monoxide gas.
- Do not run this portable generator inside homes, garages, basements, crawlspaces, sheds, or other partially-enclosed spaces even if using fans or opening doors and windows for ventilation. Carbon monoxide can quickly build up in these spaces and can linger for hours, even after this product has shut off.
- If you start to feel sick, dizzy, weak or your home's carbon monoxide alarm sounds, get to fresh air right away. Call emergency services. You may have carbon monoxide poisoning.

Carbon Monoxide Alarm(s)

Install carbon monoxide alarms inside your home. Without working carbon monoxide alarms, you will not realize you are getting sick and dying from carbon monoxide poisoning.

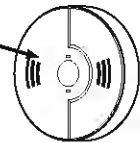

Prevent Carbon Monoxide (CO) Poisoning

Use outdoors at least 20 ft. (6.0 m) from any home.

Point exhaust away from all homes and occupied spaces.

Install CO alarms inside your home.



20 ft. (6.0 m) min.

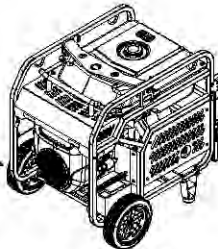

To better educate yourself about all carbon monoxide risks, go to www.takeyourgeneratoroutside.com.

OPERATION

Reduce Risk of Fire



WARNING! Exhaust heat/gases could ignite combustibles, structures or damage fuel tank causing a fire, resulting in death or serious injury.

- Keep portable generator at least 5 ft. (1.5m) from any structure, trees or vegetation over 12 in. (30 cm) in height.
- Select an outdoor site that is dry and protected from the weather. Do not move portable generator indoors to protect it from the weather.
- Do not locate the portable generator under a deck or other similar structure that may confine heat and airflow.

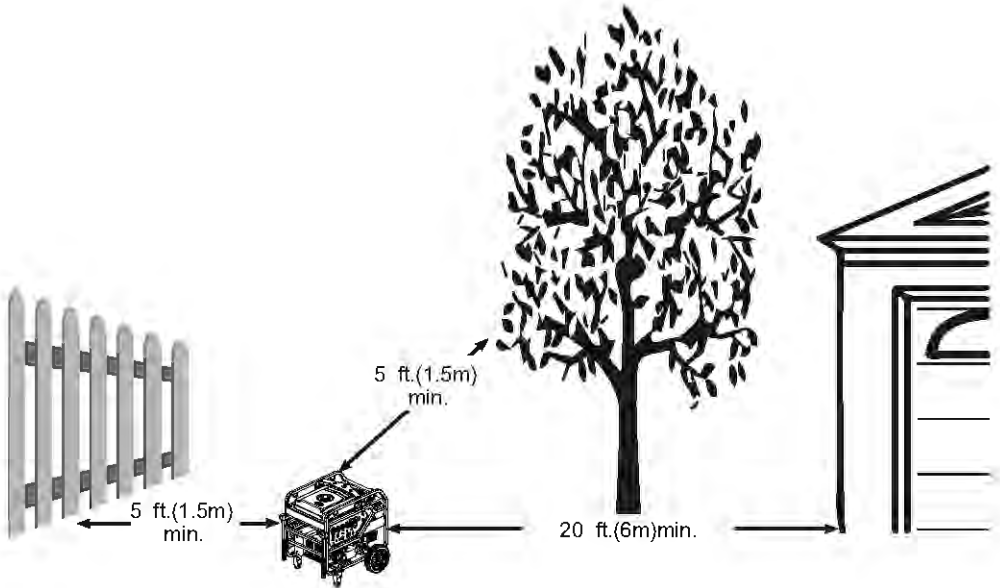

2. Oil and Gasoline

Add Engine Oil

We recommend using FIRMAN SAE 10W-30 API SL oil for best performance. Other high-quality detergent oils (API SL or higher) are acceptable. Do not use special additives. Ambient temperature determines the proper oil viscosity for the engine. Use the chart to select the proper oil for the outdoor temperature range expected.

NOTICE Do not attempt to crank or start the engine before it has been properly filled with the recommended type and amount of oil. Damage due to operation with no oil will void your warranty.

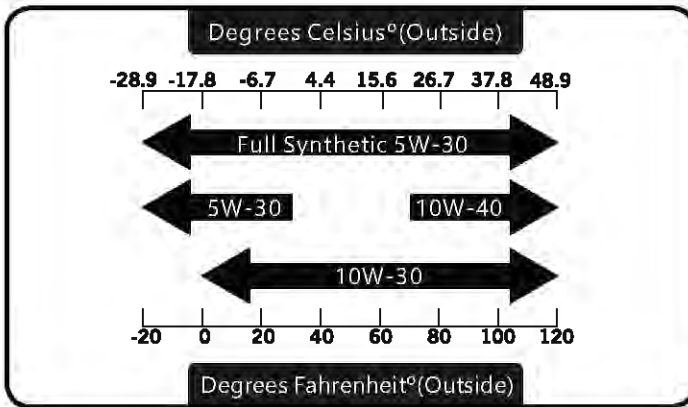

1. Place generator on a flat, level surface.
2. Open the maintenance cover.
3. Clean area around oil fill and remove yellow oil fill cap/dipstick.
4. Wipe dipstick clean.

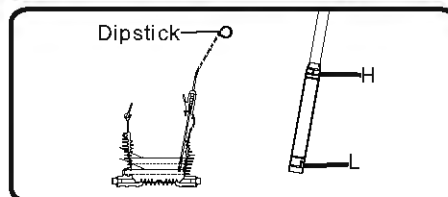
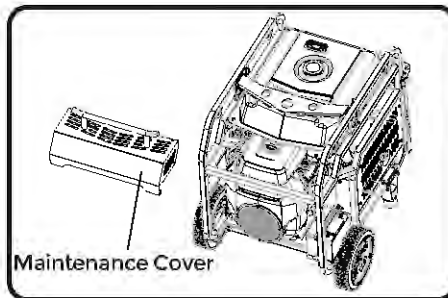

OPERATION

5. Using oil funnel, slowly pour contents of provided oil bottle into oil fill opening until oil reaches upper limit "H" mark on the dipstick. Be careful not to overfill. Overfilling could cause engine starting problems or engine damage.

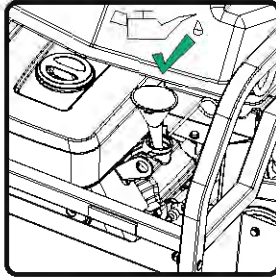

6. Replace oil fill cap/dipstick and fully tighten.

7. Oil level should be checked prior to each use or at least every 8 hours of operation. Keep oil level maintained.

8. Close maintenance cover.

Low Oil Shutdown

The portable generator is equipped with a low oil shutdown. If the oil level drops below the minimum required level, a sensor will activate an internal switch stopping the engine. If the engine shuts off and the oil level is within specifications, check to see if generator is sitting at an angle. Place portable generator on an even surface to correct this. If engine fails to start, the oil level may not be high enough to deactivate the internal low oil level switch. Make sure the sump is completely full of oil to the upper limit (H). Do not operate engine until oil level issue is corrected. Contact Firman customer service.

Add Gasoline



WARNING! Fuel and its vapors are extremely flammable which could cause burns or fire resulting in death or serious injury.

- Turn generator engine OFF and let it cool at least 2 minutes before removing fuel cap.
- Do Not refuel or move generator when engine is running.
- Move generator outdoors prior to adding or draining fuel
- Keep fuel away from any ignition sources.
- Do not overfill tank, allow space for fuel expansion.
- If any fuel spills, wait until it evaporates before starting engine
- Check and replace fuel lines, tank, cap, and fittings prior to each use if any damage or leaks are found.

Fuel must meet these requirements:

- Clean, fresh, unleaded gasoline with a minimum of 87 octane.
- For high altitude use, see Operation at High Altitude.
- Gasoline with no more than 10% alcohol is acceptable.

E10

E15

NOTICE Do not mix oil in gasoline or modify engine to run on alternate fuels not described in this manual. Use of unapproved fuels could damage engine and will not be covered under warranty.

1. Clean area around fuel fill cap, remove cap.
2. Slowly add unleaded fuel to fuel tank. Be careful not to fill above the RED fuel level indicator. This allows adequate space for fuel expansion.

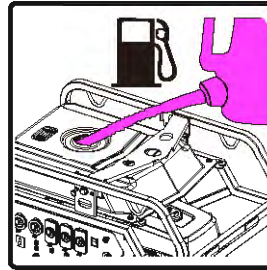
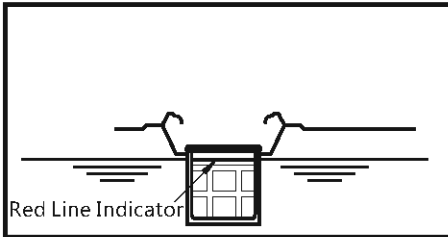

3. Install fuel cap and let any spilled fuel evaporate before starting engine.

Operation at High Altitude Gasoline Only

At altitudes over 5,000 feet(1524 meters), a minimum 85 octane gasoline is acceptable. Engine power and generator output will be reduced approximately 3.5% for every 1000 feet (305 m) of elevation above sea level. High altitude may cause hard starting, increased fuel consumption and spark plug fouling. To operate at high altitudes FIRMAN can provide a high altitude carburetor main jet. The alternative main jet and installation instructions can be obtained by contacting Customer Support. Installation instructions are also available in the Technical Bulletin area of the FIRMAN website www.firmanpowerequipment.com.

	760cc	Altitude
Altitude main jet 1	399715868	3000-6000Feet
Altitude main jet 2	399715869	6000-8000Feet

NOTICE Operation using an alternative main jet at elevations lower than the recommended minimum altitude can damage the engine. For operation at lower elevations, the standard main jet supplied must be used. Operating the engine with the wrong main jet may increase exhaust emissions, fuel consumption and reduce performance.

Operation at High Ambient conditions

Your Firman Power Equipment product is designed and rated for continuous operation at ambient temperatures up to 40°C (104°F). The generator may be operated at temperatures ranging from -15°C (5°F) to 50°C (122°F) for short periods. If the generator is exposed to temperatures outside this range during storage, the generator should be brought back within this range before operation. When operated above 77°F(25°C) there may be a decrease in power. Maximum wattage and current are subject to and limited by such factors as fuel BTU content ambient temperature, altitude, engine conditions etc.

3.Starting the Generator on Gasoline

1. Before starting the generator, check for loose or missing parts and for any damage which may have occurred during shipment. Ensure spark plugs, muffler, fuel cap, and air cleaner are all in place.
2. Move portable generator outdoors to safe operating location at least 20 feet from any occupied spaces.
3. Disconnect all electrical loads from the generator. Never start or stop the generator with electrical devices plugged in.

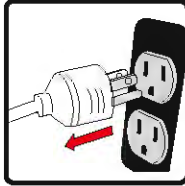

4. Turn the fuel valve to the "ON" (I) position.

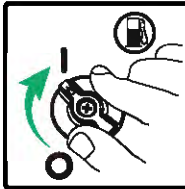

5. Flip the engine switch to the "RUN(I)" position.



6. Flip the ECO switch to the "OFF(O)" position.



6. Move choke knob located on panel to "START" position. You do not need to choke a warm engine.

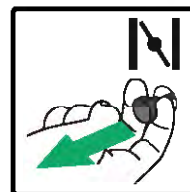

8. Flip the engine switch to the START (II) position for a few seconds and then release.



9. Do not over-choke. As soon as engine starts and warms up, slowly move the choke knob to the RUN position.



10. Allow portable generator to run at no load for a few minutes to stabilize before plugging in any electrical devices.

NOTICE If engine starts but fails to run, or if portable generator shuts down during operation, check oil level. See Low Oil Shutdown section for more information.

OPERATION

4. Connecting Electrical Loads

This portable generator has been pretested and adjusted to handle its full capacity. The voltage is regulated using an automatic voltage regulator (AVR). Readjusting the AVR will void warranty.

The duplex receptacle is equipped with GFCI protection. The GFCI protects against electric shock that may be caused if you become a path which electricity travels to reach earth. Even with a GFCI you may feel a shock, but the GFCI cuts power quickly so an average person should not suffer any injury. Manual test GFCI while generator is running to verify internal contacts will function

- Push the test button. The reset button will pop out, which should cut power to outlet.
- Press the reset button until it locks in the depressed position. If the GFCI does not reset as described do not use the receptacles. Call Firman customer service.
- If GFCI trips while in use, reset and test the outlet. Electric cords laying on the ground with worn insulation may trip the GFCI, only use cords in good condition.

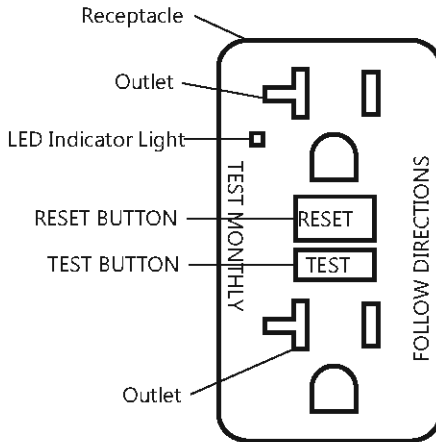

SELF-TEST OPERATION

In addition to the manual test / reset feature the GFCI receptacle tests itself periodically to confirm the GFCI electronics are functional. The indicator light will be solid green when the GFCI is powered from the generator and working correctly.

Self-test indications: If the indicator light is solid orange or flashing red a problem may exist. Press the TEST button to trip the GFCI. If unable to reset, replace the GFCI.



WARNING! Generator voltage could cause electrical shock or burn resulting in death or serious injury.

- Damaged or overloaded extension cords could overheat, arc, and burn resulting death or serious injury.
- Use a ground fault circuit interrupter (GFCI) in any damp or highly conductive area, such as metal decking.
- Do not touch bare wires or receptacles.

- Do not use generator with electrical cords which are worn, frayed, bare or otherwise damaged.
- Do not operate generator in the rain or wet weather.
- Do not run indoors to avoid wet conditions.
- Do not handle generator or electrical cords while standing in water, while barefoot, or while hands or feet are wet.
- Use listed transfer switch to prevent backfeed by isolating generator from electric utility workers.

1. Ensure circuit breaker on control panel is in the closed (on) position.
2. Start the generator with no electrical load attached.
3. Allow the engine to run for several minutes to stabilize.
4. Plug in and turn on the first item. It is best to attach the item with the largest load first.
5. Allow the engine to stabilize.
6. Plug in and turn on the next item.
7. Allow the engine to stabilize.
8. Repeat steps 5-6 for each additional item.

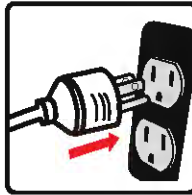

Surge Protection

There is a remote chance that voltage fluctuations may impair the proper functioning of some sensitive electronic equipment. Electronic devices, including computers and many programmable appliances may use components that are designed to operate within a narrow voltage range and may be affected by the portable generator's momentary voltage fluctuations. While there is no way to prevent all voltage fluctuations, you can take steps to protect your sensitive electronic equipment. Install a plug-in surge suppressor on the receptacles feeding your sensitive equipment. Surge suppressors come in single or multi-outlet styles. They are designed to protect against short duration voltage fluctuations.

OPERATION

CO Alert™

Carbon Monoxide (CO) Shutdown System

CO Alert automatically shuts down the engine when harmful levels of carbon monoxide accumulate around the generator or a CO Alert fault occurs. After shutdown, the CO Alert indicator light will blink for at least five minutes per the chart below.

CO Alert DOES NOT replace carbon monoxide alarms.

Install battery-powered carbon monoxide alarm(s) in your home. Don't run generator in enclosed areas.

Color	Description
Red ●●●●●	Carbon monoxide accumulated around generator. Prior to restart move generator to an open, outdoor area 20 ft. (6 m) from occupied spaces with exhaust pointed away. Air out premises (open windows and doors) before reoccupying property. Automatic shutoff is an indication generator was improperly located. If you start to feel sick, dizzy, weak, or your homes carbon monoxide alarm sounds while using this product, get to fresh air right away. Call emergency services. You may have carbon monoxide poisoning.
Yellow ●●●	CO Alert fault occurred*. See FIRMAN authorized service dealer.

*Yellow light will blink for five seconds at the startup of generator to show CO ALERT is functioning properly.

Economy Control Switch

The Economy Control switch can be activated in order to minimize fuel consumption and noise while operating the unit during times of reduced electrical output, allowing the engine speed to idle during periods of non-use. The engine speed returns to normal when an electrical load is connected. When the economy switch is off, the engine runs at normal speed continuously.

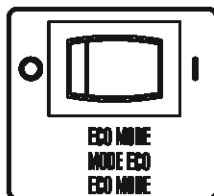

NOTICE:

For periods of high electrical load or momentary fluctuations, the Economy Control Switch should be turned OFF. For electrical appliances that can't started below 180V, the Economy Control Switch should be turned OFF.

5. Stopping the generator

1. Turn off and remove all electrical loads.

Never stop the generator with electrical devices plugged in and turned on.
Never stop the engine by moving the choke to the start position.

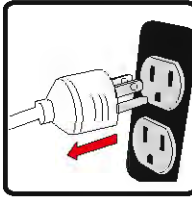

Let the generator run at no-load for one minute to stabilize internal temperatures of the engine and generator.

2. Flip the engine switch to "OFF"(O) position.

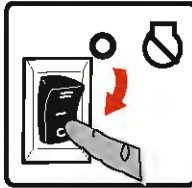

3. Turn the fuel valve to the "OFF"(O) position.

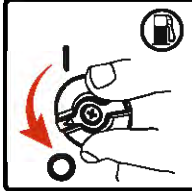

Maintenance - Storage

MAINTENANCE SCHEDULE

ITEM	NOTES	Daily(Before operation)	Initial 25 hours	Every 50 hours	Every 100 hours (or annual)	Every 250 hours
Spark Plug	Check condition. Adjust gap and clean. Replace if necessary.				✓	
Engine Oil	Check oil level.	✓				
	Replace.		✓		✓	
Oil Filter	Replace.		✓		✓	
Air Filter	Clean, replace if necessary.			✓		
Fuel	Clean fuel tank strainer. Replace if necessary.				✓	
Fuel Filter	Replace.				✓	
Fuel Line	Check fuel hose for cracks or other damage. Replace if necessary.	✓				
Exhaust System	Check for leakage. Retighten or replace gasket if necessary.	✓				
	Check spark arrester screen. Clean/Replace if necessary.				✓	
Engine	Check adjust valve clearance. *					✓
	Clean combustion chamber. *					✓
Fittings/ Fasteners	Check. Replace if necessary.				✓	

* To be performed by knowledgeable/experienced owner or by authorized service center.

General Recommendations

Regular maintenance will improve the performance and extend the life of the generator. See any authorized dealer for service.

The generator's warranty does not cover items that have been subjected to operator abuse or negligence. To receive full value from the warranty, the operator must maintain the generator as instructed in this manual.

Some adjustments will need to be made periodically to properly maintain your generator.

All service and adjustments should be made at least once each season. Follow the requirements in the maintenance schedule chart above.

NOTICE Once a year you should clean or replace the spark plugs and replace the air filter. New spark plugs and clean air filter assure proper fuel-air mixture and help your engine run at peak performance and last longer.

When Transporting Generator

Transport with fuel tank EMPTY or with fuel valve knob in OFF position.
Do not tip generator at an angle which causes fuel to spill.

ENGINE MAINTENANCE

To prevent accidental starting, remove and ground spark plug wires before performing any service.

Change Engine Oil and Oil filter

Change engine oil every 100 hours. (for a new engine, change oil and oil filter after 25 hours.)
If you are using your generator under extremely dirty or dusty conditions, or in extremely hot weather change the oil more often.

CAUTION! Avoid prolonged or repeated skin contact with used motor oil. Used motor oil has been shown to cause skin cancer in certain laboratory animals. Thoroughly wash exposed areas with soap and water.



KEEP OUT OF REACH OF CHILDREN. DON'T POLLUTE. CONSERVE RESOURCES. RETURN USED OIL TO COLLECTION CENTERS.

(a) Turn on the drain oil plug A and drain oil by the drain hose B. Removing oil filler cap while the engine is warm.

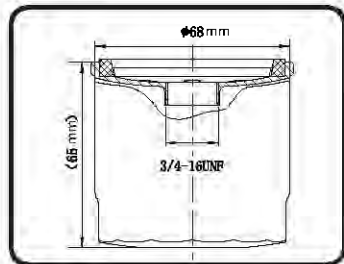
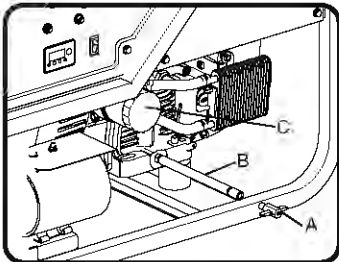

Oil Filter: FIRMAN P/N 399715751,
BOSCH 0986AF0062 or FRAM PH4967F.

(b) Change the Oil filter. Turn close the drain oil plug and fill the engine with oil until it reaches the HIGH(H) level on the oil filler dipstick.

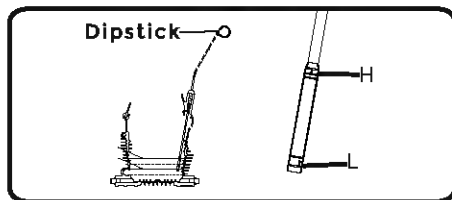
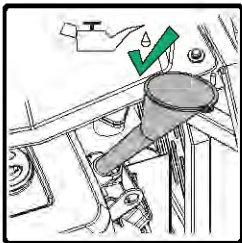

NOTICE We recommend using FIRMAN SAE 10W-30 API SL oil for best performance. Other high-quality detergent oils (API SL or higher) are acceptable. See *Oil and Gasoline*

Maintenance - Storage

Air Filter Maintenance

(a) Carefully remove foam air filter element and wash it with liquid detergent and water only. Squeeze dry in a clean cloth.

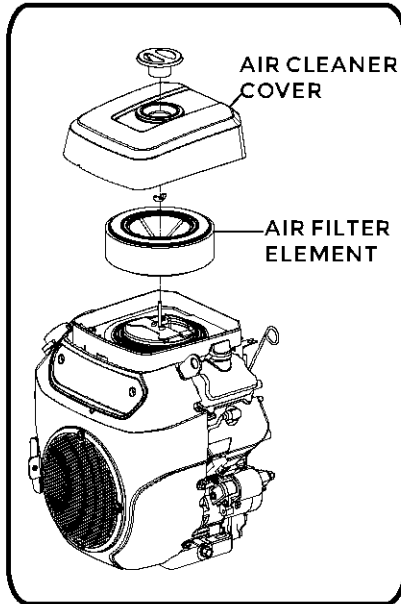

(b) Saturate foam air filter element with clean engine oil and squeeze in a clean cloth to remove excess oil.

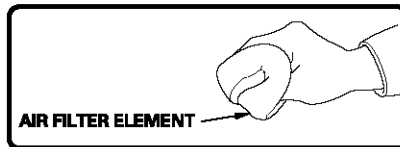

(c) Reinstall clean or new air filter element.

Spark Plug Maintenance

Changing the spark plugs will help your engine start easier and run at peak performance.

- (a) Remove the spark plug boots.
- (b) Remove spark plugs using provided wrench.

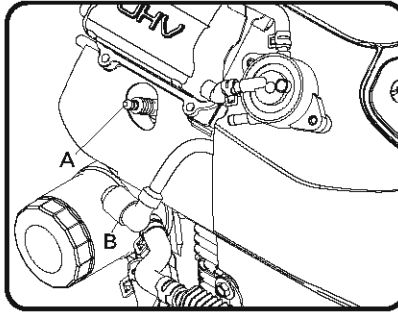

A- Spark plug
B- Spark plug boot

- (c) Inspect spark plug for damage and clean with a wire brush before reinstalling. Replace if damaged.
- (d) Adjust the electrode gap to 0.028" to 0.031" (0.7 to 0.8 mm).
- (e) Seat spark plug in position and thread by hand to prevent cross threading.
- (f) Tighten plug with provided wrench and put the spark plug boot back on spark plug.

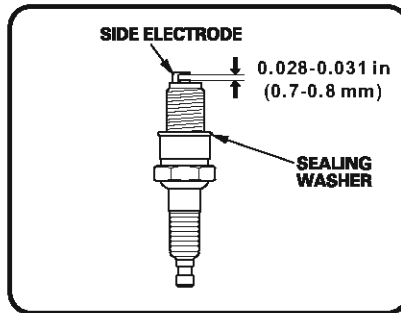

SPARK PLUG: FIRMAN P/N 330723001 or CHAMPION N9YC

Maintenance Valve Clearance

Intake: 0.004 - 0.006 in. (0.10 - 0.15 mm)
Exhaust: 0.004 - 0.006 in. (0.10 - 0.15 mm)

Muffler and Spark Arrester



WARNING! Contact with muffler area could cause burns resulting in serious injury.

- Do not touch hot parts.
- It is a violation of California Public Resource Code, Section 4442, to use or operate the engine on any forest-covered, brush-covered, or grass-covered land unless the exhaust system is equipped with a spark arrester, as defined in Section 4442, maintained in effective working order. Other states or federal jurisdictions may have similar laws, reference Federal Regulation 36 CFR Part 261.52.

Maintenance - Storage

Inspect Muffler and Spark Arrester

1. Inspect the muffler for cracks, corrosion, or other damage.
2. Remove the screws securing the spark arrester in place and then remove it from the muffler.

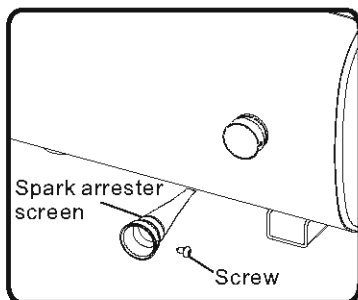

3. Carefully remove the carbon deposits from the spark arrester screen with a wire brush.

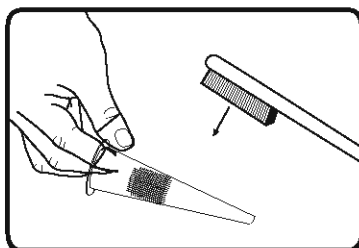

4. Replace the spark arrester if it is damaged. If replacement parts are required, make sure to use only FIRMEN original equipment replacement parts.
5. Position the spark arrester in the muffler and attach with the screws.

NOTICE Failure to clean or replace spark arrester may result in decreased engine performance.

GENERATOR MAINTENANCE

Run the generator at least 30 minutes every month.

Make certain that the portable generator is kept clean and dry.

Do not expose the unit to excessive dust, dirt, moisture or corrosive vapors.

Do not insert any objects through cooling slots.

Before each use inspect underneath the generator for signs of oil or fuel. Clean any accumulated debris. Keep area around muffler free from any debris. Use a soft bristle brush to remove dirt or caked on oil. Use a damp cloth to clean all exterior surfaces.

Battery Replacement

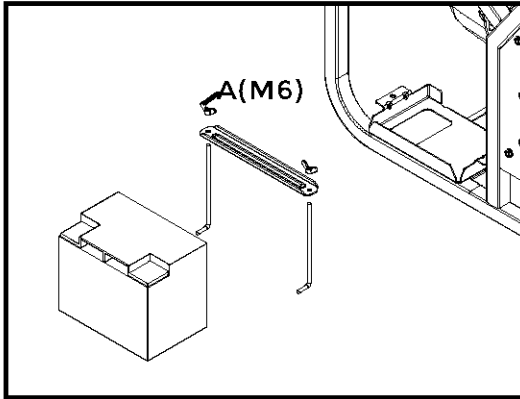

1. Remove the spark plug boot from spark plugs.
2. Remove the nut and bolt from the negative(-) post first, then the positive(+) post.
3. Loosen and remove the wing nuts (A) on the battery holding bracket.
4. Remove the battery and recycle.
5. Install the new battery with the following specification:
 - 12V sealed lead acid 33AH
 - LXWXH:7.67X5.12X6.3inch (195X130X160mm)
6. Connect the red positive (+) battery cable to the battery first.
7. Connect the black negative (-) battery cable to the battery second.
8. Cover the posts with boots provided.
9. Install the spark plug boot onto spark plugs.

Battery Charging

The battery powers the starter motor and control module. This portable generator is equipped with an automatic battery charging circuit. The battery will receive charging voltage only when the engine is running. The battery will maintain a proper charge if the portable generator is used on a regular basis (about once every two weeks). If it is used less frequently, the battery should be connected to the trickle charger provided to keep the battery properly charged. If the battery is not able to start the engine, the battery must be connected to a standard automotive style battery charger for re-charging before it can be used.

Long Term Storage

It is important to prevent gum deposits from forming in essential fuel system components such as the carburetor, fuel hoses or tank during storage. Alcohol-blended fuels (called gasohol, ethanol or methanol) attract moisture, which leads to separation and formation of acids during storage. Acidic gas can damage the fuel system of an engine while in storage.

When the generator set is being stored for more than one month, follow these instructions to avoid engine problems:



WARNING! Fuel and its vapors are extremely flammable which could cause burns or fire resulting in death or serious injury.

Do not store fuel near any ignition sources.

When draining fuel move generator outdoors and use a commercially available non-conductive vacuum siphon. Fuel must be drained into an approved container.

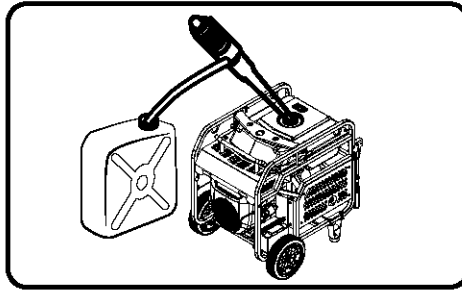

1-Treat any stored fuel with fuel stabilizer.

2-When storing generator with gasoline in fuel tank, operate the engine for 5-10 minutes to circulate treated fuel into fuel lines and carburetor before shutdown.

3- There is no need to drain gasoline from the generator fuel tank if fuel stabilizer is added.

4-FUEL STARVATION: If you elect to drain fuel tank move generator outdoors. Once fuel tank is drained turn fuel valve knob to on position. Start and run the portable generator outdoors until engine stops from lack of gasoline. This will drain remaining gasoline from tank, fuel lines, and carburetor.

5-Always turn fuel valve knob to OFF position prior to storage.

6-Allow the portable generator to cool before cleaning and storage.

7-Change oil .

8-Remove spark plug boots and spark plugs. Pour about one teaspoon of engine oil through the spark plug holes, cover each spark plug hole with a clean rag then quickly jog the engine three times with the engine switch to distribute the oil in the cylinders. Reinstall the spark plugs and attach the spark plug boots.

9-Cover the portable generator and store in a clean, dry place out of direct sunlight and away from any ignition sources.

Any damage or hazards caused by using improper fuel, improperly stored fuel, and/or improperly formulated stabilizers, are not covered by manufacturer's warranty.

Do not store gasoline from one season to another season.

Troubleshooting - Specifications

Problem	Cause	Correction
Engine is running, but no AC output is available.	<ol style="list-style-type: none"> 1. Circuit breaker is open. 2. Fault in generator. 3. Poor connection or defective cord set. 4. Connected device is bad. 	<ol style="list-style-type: none"> 1. Reset circuit breaker. 2. Contact authorized service facility. 3. Check and repair. 4. Connect another device that is in good condition.
Engine runs good at no-load but "bogs down" when loads are connected.	<ol style="list-style-type: none"> 1. Short circuit in a connected load. 2. Engine speed is too slow. 3. Shorted generator circuit. 4. Clogged or dirty fuel filter. 	<ol style="list-style-type: none"> 1. Disconnect shorted electrical load. 2. Contact authorized service facility. 3. Contact authorized service facility. 4. Clean or replace fuel filter.
Engine will not start; starts and runs rough or shuts down when running.	<ol style="list-style-type: none"> 1. Fuel switch set to OFF (O) position. 2. The indicator light is OFF or flashing red. 3. Low oil level. 4. Dirty air cleaner. 5. Out of gasoline. 6. Stale gasoline. 7. Spark plug wires not connected to spark plugs. 8. Bad spark plugs. 9. Water in gasoline. 10. Flooded. 11. Excessively rich fuel mixture. 12. Clogged or dirty fuel filter. 13. Starting battery may have insufficient charge. 14. Out of battery power. 	<ol style="list-style-type: none"> 1. Set fuel switch to "ON" position. 2. Must have solid red indicator light to be able to start the engine. 3. Fill crankcase to proper level or place generator on level surface. 4. Clean or replace air cleaner. 5. Fill fuel tank with gasoline. 6. Drain fuel tank and carburetor; fill with fresh gasoline. 7. Connect wires to spark plugs. 8. Replace spark plugs. 9. Drain gas tank and carburetor; fill with fresh gasoline. 10. Wait 5 minutes and re-crank engine. 11. Contact authorized service facility. 12. Clean or replace fuel filter. 13. Check battery output and charge battery as necessary. 14. Start Engine to charge or replace battery.
Engine lacks power.	<ol style="list-style-type: none"> 1. Load is too high. 2. Dirty air filter. 3. Clogged or dirty fuel filter. 4. Clogged spark arrester. 	<ol style="list-style-type: none"> 1. Don't Overload Generator 2. Replace air filter. 3. Clean or replace fuel filter. 4. Clean or replace spark arrester.
Engine "hunts" or falters.	<ol style="list-style-type: none"> 1. Carburetor is running too rich or too lean. 2. Clogged or dirty fuel filter. 	<ol style="list-style-type: none"> 1. Contact authorized service facility. 2. Clean or replace fuel filter.
Engine shuts down when running.	<ol style="list-style-type: none"> 1. Out of gasoline. 2. Dirty air cleaner. 3. Low oil level. 	<ol style="list-style-type: none"> 1. Fill fuel tank with gasoline. 2. Clean or replace air cleaner. 3. Fill crankcase to proper level or place generator on level surface.

For all other issues, contact authorized dealer or Firman customer service.

Troubleshooting - Specifications

SPECIFICATIONS

Model	P12002
Starting Watts	15000
Running Watts*	12000
Rated AC Voltage	120/240V
Rated Frequency	60Hz
Phase	Single
Voltage Regulator	AVR
Power Factor	1
Alternator Type	Brushed
Engine	FIRMAN
Engine Type	V-twin, 4-Stroke OHV Air Cooled
Displacement	760cc
Low Oil Shutdown	Yes
Ignition System	Breakless Ignition Type, Flywheel Magneto
Starting System	Electric Start
Fuel	Unleaded Automotive Gasoline
Capacity Fuel Tank	13.3 U.S. Gallons (50.2L)
Lubricating Oil Capacity	50.7 oz (1.5L)
Carburetor Type	Float
Air Cleaner	Polyurethane Type
P.T.O. Shaft Rotation	Counter Clockwise (Facing P.T.O.)
Oil Type	See "Add Engine Oil" Section
AC Grounding System	Neutral Bonded To Frame

*Generator certified in accordance with CSA (Canadian Standards Association) standard C22.2 No. 100-14, Motors and Generators.

760cc ENGINE PARTS DIAGRAM

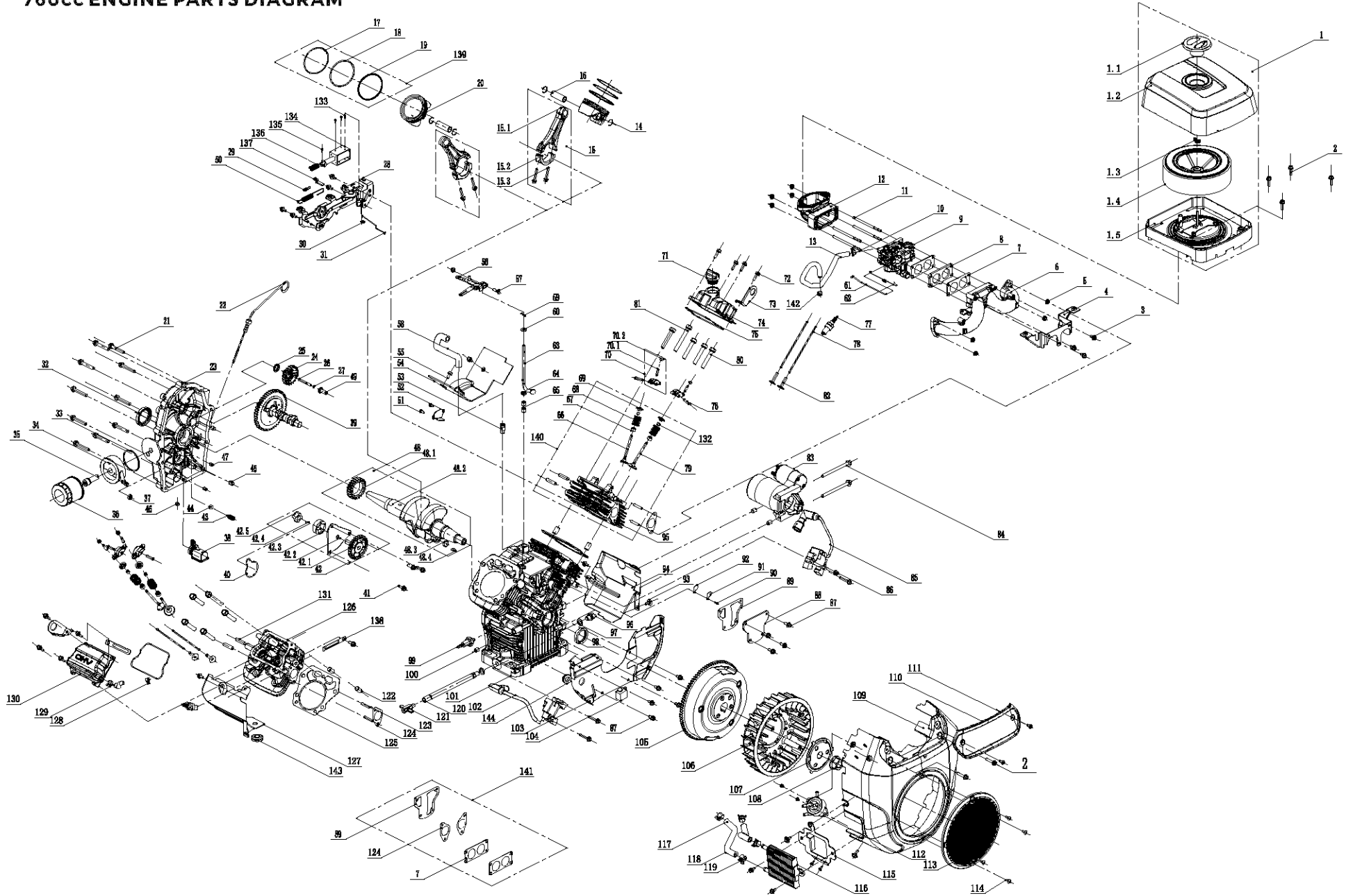

Parts Diagrams - Parts Lists - Wiring Diagram

P12002 Portable Generator

NO.	Part Number	Description	Qty.	NO.	Part Number	Description	Qty.
1	399465500	Engine Subassembly	1	30	399415642	Fuel Tank Assy	1
2	399455610	Alternator Assy	1	30.1	399725643	Grommet, Fuel Tank	4
2.1	399711050	Generator Front Cover	1	30.2	399715644	Bushing	4
2.2	399755611	Rotor Comp	1	30.3	399715645	Fuel Tank	1
2.3	399715614	Bolt M10×295	1	30.4	336713548	Fuel Filter, Wire Mesh	1
2.4	399755612	Stator Assy	1	30.5	336713807	Fuel Hose Connector	1
2.5	399715613	Stator Cover	1	31	393713018	Bolt M6×20	4
2.6	399711052	Generator End Cover	1	32	336713549	Fuel Tank Cap Comp.	1
2.7	399715615	Bolt M10×195	4	33	336713547	Fuel Gauge Display	1
2.8	399715616	Self Tapping Screw 5.5×80	2	34	336713546	Screw M5×10	2
2.9	399755617	Terminal Block	1	35	399715646	Fuel Gauge Assy.	1
2.10	399715618	Bolt & washer M6×25	2	36	330713508	Clamp Ø10.5×8	4
2.11	357713563	Bolt & washer M5×20	2	37	399725650	Hose, Fuel	1
2.12	399715619	Generator End Cover Cap	1	38	399725648	Formed Vapor Hose	1
2.13	399725620	Rubber Sleeve	1	39	330713509	Clamp Ø8.7×8	3
3	399715621	Flange Bolt M10×25	4	40	399715649	Fuel Filter	1
4	399451021	Carbon Brush Assembly	1	41	399725650	Hose, Fuel	1
5	399715622	AVR-bracket	1	42	357713546	Sleeve	1
6	399755623	Control Module	1	43	399725652	Vapor Hose 2	1
7	399755624	AVR	1	44	399715502	Clamp Ø8.7×6	1
8	330713502	Screw M5×20	2	45	399725653	Buffer Washer	2
9	399715625	Flat Washer	1	46	330713591	Screw&washer Assy M5×38	7
10	399715626	Bolt	4	47	399725654	Corrugated Pipe ø23	1
11	317718304	Flange Bolt M6×20	2	48	399725655	Cable Connector I	1
12	336718329	Flange Bolt M6×15	1	49	399725656	Pull Chock Assembly	1
13	336718302	Flange Bolt M6×12	27	50	399715657	Flange Bolt M5×16	2
14	357713563	Bolt & washer M5×20	1	51	399715658	Fuel Valve	1
15	317713539	Diode Module	1	52	399725659	Control Box	1
16	399755627	Ground Wire	1	53	399725660	Cable Connector II	1
17	336718301	Flange Bolt M6×12	2	54	399725661	Corrugated Pipe Ø12	1
18	393713008	External Teeth Lock Washer ø6	1	55	330713594	Circuit Breaker Amp 20A	2
19	336718326	The Flange Nut M6	1	55.1	336713569	Screw&washer Assy M4×8	10
20	399715628	Muffler Assembly	1	56	336713586	Circuit Breaker Amp 30A	2
20.1	399715629	Muffler	1	57	330713614	Circuit Breaker Amp 10A	1
20.2	399715630	Protector, Muffler	1	58	336718324	The Flange Nut M4	12
20.3	330723590	Screw M3×6	1	59	399755662	Engine Switch	1
21	399715631	Exhaust Gasket	1	60	336718322	The Flange Nut M3	2
22	399715632	Muffler Gasket	2	61	399755663	Multi Meter	1
23	399715633	Exhaust Pipe	1	62	399715507	Control Panel	1
24	399715634	Flange Bolt M8×25	4	63	317713549	Fuel Valve Knob	1
25	399715635	Exhaust Pipe Cover	1	64	317713516	Screw&washer Assy M4×14	1
26	336718318	The Flange Nut M8	8	65	399755501	Idle Switch Cover	1
27	399715636	Flange Bolt M8×20	2	66	357713541	Outlet Cover 5-20R GFCI	2
28	336718318	The Flange Nut M8	4	67	336713674	Outlet Cover, Cigarette Lighter	1
29	399725637	Carbon Canister Assy	1	68	399725666	Outlet Cover, Battery Charge	1
29.1	336718313	The Flange Nut M6	4	69	336713573	Outlet Cover L14-30R	3
29.2	399715638	Carbon Canister Cover	1	70	336718355	Screw&washer Assy M3×6	4
29.3	399715639	Carbon Canister Shield	2	71	336713574	Outlet Cover 14-50R	1
29.4	399715640	Carbon Canister Bracket	2	72	399715667	Bolt M6×45	1
29.5	399715641	Carbon Canister	1	73	357713543	Nut M6	3

Parts Diagrams - Parts Lists - Wiring Diagram

NO.	Part Number	Description	Qty.	NO.	Part Number	Description	Qty.
74	336713513	Flat Washers Ø6	2	123	357713519	Cover, Handle	2
75	393713008	External Teeth Lock Washer Ø6	1	124	336718315	The Flange Nut M8	4
76	336713512	Spring Washer Ø6	2	125	399755703	Ground Wire 8 AWG	1
77	317713565	DC Outlet 12V/8.3A	1	126	399725704	Sheath Black	2
78	330713618	Battery Charging Port	1	127	399755705	Red Wire 120 8awg	1
79	380713518	Receptacle 14-50R	1	128	399725706	Sheath Red	1
80	336713601	Receptacle L14-30R	1	129	399755707	Black Wire 300 8awg	1
81	336713832	Receptacle L5-30R	2	130	336713507	Flange Bolt M5×12	2
82	357713588	Receptacle GFCI	2	131	393728308	The Flange Nut M5	2
83	399755668	Circuit Breaker Amp 50A	1	132	399725501	Hose,fuel	1
84	380713526	Circuit Breaker Amp 30A	1	133	399715501	Clamp Ø14	1
85	330713502	Screw M5×20	3	134	399725503	Heat Proof Mat	1
86	399755669	Idle Module	1	135	399725500	Sleeve	1
87	357713558	The Flange Nut M5	3	136	392758302	Cover	1
88	399715670	Handle Flip	1	137	393725501	Breaker Cover	1
88.1	399725671	Grommet	2	138	340725503	Switch Cover	1
89	399715672	Knob Bolt	2	139	336755002	Indicator Light	1
90	399715673	Flip Cover	1	140	336755005	Breaker Cover	1
91	336718320	Flange. Bolt M8×45	8	141	399755502	Co Module	1
92	399725502	Sleeve	0.2	142	399755503	Relay	1
93	336718318	The Flange Nut M8	12	143	399755505	Conversion Wire	1
94	336718302	Flange. Bolt M6×12	15				
95	399715675	Axle Pin, Handle	4				
96	399715676	Hook Bracket	1				
97	399715677	Flange. Bolt M14×50	2				
98	399715678	Self-locking Nut M14	2				
99	399725679	Nylon Washers Ø14	2				
100	380713562	Screw&washer M5×8	4				
101	399715681	Muffler Cover	1				
102	399715682	Wing Nut M6	2				
103	399715683	Battery Pressing Plate	1				
104	399715684	Bolt M6×165	2				
105	399755685	Battery 33AH	1				
106	399715686	Frame Assy	1				
107	399715687	Support Leg	2				
108	399715688	Cotter Pin Ø3.2×40	2				
109	399715689	Washer Φ16	2				
110	399725690	Wheel 12"	2				
111	399715691	Axle Pin	1				
112	336713559	Flange Bolt M8×16	4				
113	399725692	Rubber, Support	2				
114	399715693	Tubing Retaining Plate	1				
115	399715694	Front Plate. Frame	1				
116	399715695	Isolator Assy. I	2				
117	357713531	The Flange Nut M10	8				
118	399715697	Base Assy	1				
119	399715698	Supports	2				
120	399725699	Isolator Assy. li	2				
121	399715700	Beam.frame	1				
122	399715701	Handle Assembly	1				

Parts Diagrams - Parts Lists - Wiring Diagram

FIRMAN 760cc Engine

NO.	Part Number	Description	Qty.	NO.	Part Number	Description	Qty.
1	399425708	Air filter	1	42.1	399715758	Oil pump gear shaft	1
1.1	399725709	Air filter cover nut	1	42.2	399715759	Oil pump pressure plate	1
1.2	399725710	Air filter cover	1	42.3	399715760	Oil pump rotor	1
1.3	357713550	Butterfly nut M6	1	42.4	399715761	Rolling pin 4 × 15.8	1
1.4	399715712	Filter assembly	1	42.5	399715762	Oil pump rotor	1
1.5	399715713	Air filter seat assembly	1	43	399715763	Pressure spring	1
2	399715714	Flange bolt M6 × 22	6	44	399715764	Steel ball 15/32 (Ø11.906)	1
3	336718301	Flange bolt M6 × 12	22	45	399715765	Position pin Ø10 × 12	4
4	399715716	Oil connecting seat	1	46	399715766	Bowl of plug 11	1
5	336713517	Hexagon flange nut M6	9	47	336723610	Pin Ø8 × 10	2
6	399715718	Intuitive manifold	1	48	399415768	Crankshaft assembly	1
7	399715719	Oil gasket	2	48.1	399715769	Crankshaft timing gear	1
8	399715720	Template	1	48.2	399715770	Crankshaft	1
9	399715721	Oil combination	1	48.3	399715771	Bowl type expansion plug	1
10	399715722	Clamp Ø12 × 8	3	48.4	399715772	GB/T 1099 5 × 16	1
11	399715723	Screw M6 × 113	4	49	399715773	Speed regulation gear sleeve	1
12	399715724	Oil connecting seat	1	50	399715774	Speed control spring 1	1
13	399715725	Fuel line	1	51	399715775	Cross screw assembly M5 × 12	2
14	399715726	Ring, Piston pin	4	52	399715776	Vent cover	1
15	399715727	Link assembly	2	53	399715777	Pipe, Ventilation chamber	1
15.1	399715728	Linkage	2	54	399715778	Wind scooper assembly	1
15.2	399715729	Linkage cover	2	55	399715779	Shaped bolts	2
15.3	399715730	Link bolt	4	56	399715780	Plunger arm	1
15	399715731	Piston pin	2	57	336723567	Plunger arm bolt	1
17	399715732	First piston ring	2	58	399715782	Ventilator	1
18	399715733	Second piston ring	2	59	399715783	Spring pin	1
19	399715734	Oil ring	2	60	336723564	Washer	4
20	399715735	Piston	2	61	399715785	Governor tie rod	1
21	399715736	Bolt M8 × 50	10	62	399715786	Spring	1
22	399715737	Dipstick	1	63	399715787	Rocker	1
23	399715738	Crankcase cover	1	64	399715788	Oil seal, Rocker	1
24	399715739	Governor gear	1	65	399715789	Needle bearing HK0810	2
25	336723564	Governor gear shaft gasket	1	66	399715790	Exhaust valve	2
26	399715741	Governor gear shaft	1	67	399715791	Valve seal	4
27	336723597	Jump ring	1	68	399715792	Valve spring	4
28	399715743	Governor bracket	1	69	399715793	Guide valve spring	4
29	399715744	Speed regulating spring	1	70	399715794	Rocker arm assembly	4
30	399715745	Positioning bracket	1	70.1	317723575	Adjust stud	4
31	399715746	Choke lever	1	70.2	317723574	Nut	4
32	399715747	Oil seal 41 × 56 × 8	1	71	399715797	Oil Plug	1
33	399715748	Oil seal	1	72	399715798	Flange bolt M6 × 22	8
34	399715749	Oil filter base	1	73	399715799	Lifting lug	2
35	399715750	Oil filter base bolt	1	74	399715800	Cylinder cover (left)	1
36	399715751	Oil filter	1	75	399715801	Cylinder cover gasket	2
37	399715752	Sealing gasket	1	76	399715802	Rocker shaft	4
38	399715753	Oil filter assembly	1	77	330723557	Spark plug	2
39	399715754	Cam shaft assembly	1	78	399715804	Push rod	4
40	399715755	Oil pump seal	1	79	399715805	Intake valve	2
41	399715756	Flange bolt M6 × 20	3	80	399715806	Bolt M10 × 75	2
42	399415757	Oil pump	1	81	399715807	Bolt M10 × 55	8

Parts Diagrams - Parts Lists - Wiring Diagram

NO.	Part Number	Description	Qty.	NO.	Part Number	Description	Qty.
82	399715808	Pillar	4	132	399715858	Valve lock clamp	8
83	399715809	Start Motor combination	1	133	399715859	Screw M3 × 8	4
84	399715810	Flange bolt M8 × 105	2	134	399715860	Electromagnet assembly	1
85	399715510	Ignition coil	1	135	399715861	Screw M4 × 20	1
86	399715812	Flange bolt M6 × 45	4	136	399715862	Support spring, Electromagnet	1
87	399715813	Flange bolt M6 × 15	9	137	399715863	Idle rod	1
88	399715814	Vent chamber cover	1	138	399715864	Flange nut M4	1
89	399715815	Vent chamber cover pad	1	139	399715504	Piston Ring Set	2
90	399715816	Cross screw M3 × 8	1	140	399715505	Cylinder Head Comp	2
91	399715817	Stopper plate	1	141	399715506	Gasket Set	1
92	399715818	check valve slice	1	142	399715501	Tube Clip	1
93	399715819	Shaped bolt	4	143	399725504	Rubber Sleeve	1
94	399715820	Left guide	1	144	399725505	Rubber Sleeve Air Guide Board	1
95	399715821	Cylinder cover assembly (left)	1				
96	35723501	Oil drain bolt M12 × 1.25 × 15	1				
97	35723502	Oil drain bolt washer 12 × 20 × 2	1				
98	399715824	Oil seal 35 × 48 × 8	1				
99	399715825	Oil pressure alarm	1				
100	399715826	Hexagonal plug	1				
101	399715827	Crankcase assembly	1				
102	399715509	Ignition coil (right)	1				
103	399715829	Leading broad assembly	1				
104	399755504	Control module	1				
105	399715831	Flywheel assembly	1				
106	399715832	Cooling fan	1				
107	399715833	Fan block	1				
108	399715834	Flange nut M20 × 1.5	1				
109	399715835	Fan cover assembly	1				
110	399715836	Cover	1				
111	399715837	Self-tapping screw ST5.5 × 13	6				
112	399715838	Gasoline pump	1				
113	399715839	Screen	1				
114	399715840	Screw	4				
115	399715841	Oil cooler supporting plate	1				
116	399715842	Oil cooler	1				
117	399715843	Oil pipe	2				
118	399715844	Screw	4				
119	399715845	Clamp Ø15 × 12	4				
120	399715846	Quick oil drain pipe	1				
121	336723604	Oil drain bolt (1006)	1				
122	35723544	Pin Ø12 × 20	4				
123	330723555	Bolts M6 × 32	4				
124	399715850	Inlet gasket	2				
125	399715851	Cylinder cover	2				
126	399715852	Cylinder cover (right)	1				
127	399715853	Wind scooper, Right	1				
128	393713040	Clamp Ø9.4 × 8	1				
129	399715855	Negative pressure tube	1				
130	399715856	Cylinder cover (right)	1				
131	399715857	Bolt M8 × 35	4				

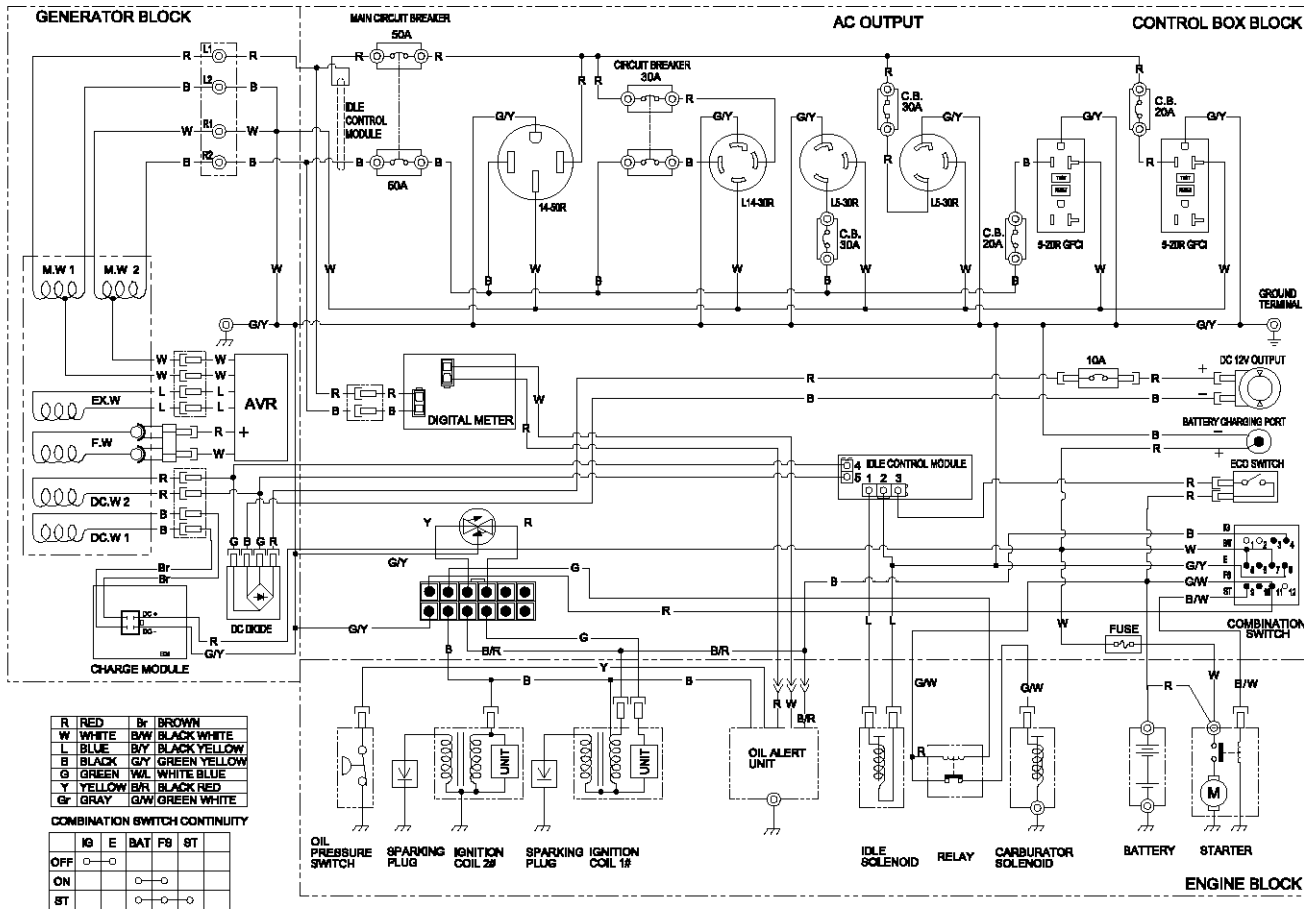

Service – Warranty

FOR SERVICE INFORMATION CONTACT FIRMAN PRODUCT SERVICE DEPARTMENT AT 1-844-347-6261 or at www.firmanpowerequipment.com to obtain warranty service information or to order replacement parts or accessories.

HOW TO ORDER REPLACEMENT PARTS

Even quality-built equipment such as this electric generator may need occasional replacement parts to maintain it in good condition over the years. To order replacement parts, please give the following information:

- Model No. Rev. Level and Serial No. found on the data decal.
- Parts number or numbers as shown in the Parts List section.
- A brief description of the trouble with the generator.

FIRMAN Three (3) Year Limited Warranty

Warranty Qualifications

FIRMAN GENERATOR will register the warranty upon receipt of your Warranty Registration Card and a copy of your sales receipt from one of FIRMAN's retail locations as proof of purchase. Please submit your warranty registration and your proof of purchase within ten(10) days of the date of purchase.

Repair/Replacement Warranty

FIRMAN warrants to the original purchaser that the mechanical and electrical components will be free of defects in material and workmanship for a period of one(1) year(parts and labor) and three(3) years (parts and technical support) from the original date of purchase 90 days [parts and labor] and 180 days [parts] for commercial & industrial use. Transportation charges on product submitted for repair or replacement under this warranty are the sole responsibility of the purchaser. This warranty only applies to the original purchaser and is not transferable.

Do Not Return the Unit to the Place of Purchase

Contact the FIRMAN Service Center and FIRMAN will troubleshoot any issue via phone or e-mail. If the problem is not corrected by this method, FIRMAN will, at its option, authorize evaluation, repair or replacement of the defective part or component at a FIRMAN Service Center. FIRMAN will provide you with a case number for warranty service. Please keep it for future reference. Repairs or replacements without prior authorization, or at an unauthorized repair facility, will not be covered by this warranty.

Warranty Exclusions

This warranty does not cover the following repairs and equipment.

Normal Wear

Your product needs periodic parts and service to perform well. This warranty does not cover repair when normal use has exhausted the life of a part or the equipment as a whole.

Installation, Use and Maintenance

This warranty will not apply to parts and/or labor if your product is deemed to have been misused, neglected, involved in an accident, abused, loaded beyond the generator's limits, modified, installed improperly or connected incorrectly to any electrical component. Normal maintenance is not covered by this warranty.

Other Exclusions

This warranty excludes:

- cosmetic defects such as paint, decals, etc.
- wear items
- accessory parts
- failures due to acts of God and other force majeure events beyond the manufacturer's control
- problems caused by parts that are not original FIRMAN parts
- units used for prime power in place of existing utility power where utility is present or in place of utility power where utility power service does not normally exist.

Limits of Implied Warranty and Consequential Damage

FIRMAN disclaims any obligation to cover any loss of time, use of this product, freight, or any incidental or consequential claim by anyone from using this product. THIS WARRANTY IS IN LIEU OF ALL OTHER WARRANTIES, EXPRESS OR IMPLIED, INCLUDING WARRANTIES OF MERCHANTABILITY OR FITNESS FOR A PARTICULAR PURPOSE.

A unit provided as an exchange will be subject to the warranty of the original unit. The length of the warranty governing the exchanged unit will remain calculated by reference to the purchase date of the original unit.

This warranty gives you certain legal rights which may change from state to state. Your state may also have other rights you may be entitled to that are not listed within this warranty.

Contact Information

You may contact FIRMAN at:

Address

Firman Power Equipment Inc.
Attn: Customer Service
8644 W. Ludlow Dr.
www.firmanpowerequipment.com
Peoria, AZ 85381

We are FIRMAN POWER - And we are here for you.

Service – Warranty

FIRMAN POWER EQUIPMENT INC. Emission Control System Warranty

CALIFORNIA AND FEDERAL EXHAUST AND EVAPORATIVE EMISSIONS CONTROL WARRANTY STATEMENT

YOUR WARRANTY RIGHTS AND OBLIGATIONS

The California Air Resources Board, US Environmental Protection Agency ("US EPA") and FIRMAN POWER EQUIPMENT INC. (FIRMAN) are pleased to explain the emissions control systems warranty on your 2022-2023 or later Small Off-Road Engine ("SORE") and engine powered equipment. In California, new equipment that use small off-road engines must be designed, built and equipped to meet the State's stringent anti-smog standards. FIRMAN must warrant the emissions control systems on your SORE and engine powered equipment for the periods of time listed below provided there has been no abuse, neglect or improper maintenance of your small off-road engine or equipment leading to the failure of the emissions control system.

Your emissions control system may include parts such as the carburetor or fuel-injection system, the ignition system, catalytic converter, fuel tanks, fuel lines (for liquid fuel and fuel vapors), fuel caps, valves, canisters, filters, clamps and other associated components. Also included may be hoses, belts, connectors, and other emission-related assemblies.

Where a warrantable condition exists, FIRMAN will repair your SORE and engine powered equipment at no cost to you including diagnosis, parts and labor.

MANUFACTURER'S WARRANTY COVERAGE:

The exhaust and evaporative emissions control system on your small off-road engine and engine powered equipment is warranted for two years. If any emissions-related part on your small off-road engine and engine powered equipment is defective, the part will be repaired or replaced by FIRMAN.

OWNER'S WARRANTY RESPONSIBILITIES:

As the SORE and engine powered equipment owner, you are responsible for the performance of the required maintenance listed in your operator's manual. FIRMAN recommends that you retain all receipts covering maintenance on your SORE and engine powered equipment, but FIRMAN cannot deny warranty coverage solely for the lack of receipts or for your failure to ensure the performance of all scheduled maintenance.

As the SORE and engine powered equipment owner, you should however be aware that FIRMAN may deny you warranty coverage if your small off-road engine or engine powered equipment or a part has failed due to abuse, neglect, or improper maintenance or unapproved modifications.

You are responsible for presenting your small off-road engine and engine powered equipment to a FIRMAN distribution center or service center as soon as the problem exists. The warranty repairs shall be completed in a reasonable amount of time, not to exceed 30 days.

If you have any questions regarding your warranty rights and responsibilities, you should contact FIRMAN at 1-844-347-6261 or support@firmanpowerequipment.com.

FIRMAN Emission Control Defects Warranty Provisions

The warranty period begins on the date the engine/equipment is delivered to an ultimate purchaser. FIRMAN warrants to the ultimate purchaser and each subsequent purchaser that the engine is:

Designed, built, and equipped so as to conform with all applicable regulations adopted by the Air Resources Board and US EPA; and Free from defects in materials and workmanship that cause the failure of a warranted part to be identical in all material respects to the part as described in the engine manufacturers application for certification.

The warranty on emissions-related parts is as follows:

- (1) Any warranted part that is not scheduled for replacement as required maintenance in the owner's manual supplied, is warranted for the warranty period stated above. If any such part fails during the period of warranty coverage, the part will be repaired or replaced by FIRMAN at no charge to the owner. Any such part repaired or replaced under the warranty will be warranted for the remaining warranty period.
- (2) Any warranted part that is scheduled only for regular inspection in the owner's manual supplied, is warranted for the warranty period stated above. Any such part repaired or replaced under warranty will be warranted for the remaining warranty period.
- (3) Any warranted part that is scheduled for replacement as required maintenance in the owner's manual supplied, is warranted for the period of time prior to the first scheduled replacement point for that part. If the part fails prior to the first scheduled replacement, the part will be repaired or replaced by FIRMAN at no charge to the owner. Any such part repaired or replaced under warranty will be warranted for the remainder of the period prior to the first scheduled replacement point for the part.
- (4) Repair or replacement of any warranted part under the warranty must be performed at no charge to the owner at a warranty station.
- (5) Notwithstanding the provisions of Subsection (4) above, warranty services or repairs must be provided by FIRMAN that are franchised to service the subject engines.
- (6) The owner must not be charged for diagnostic labor that leads to the determination that a warranted part is in fact defective, provided that such diagnostic work is performed at a warranty station.
- (7) FIRMAN is liable for damages to other engine components proximately caused by a failure under warranty of any warranted part.

- (8) Throughout the emissions warranty period defined in Subsection (b)(2), FIRMAN will maintain a supply of warranted parts sufficient to meet the expected demand for such parts.
- (9) Any replacement part may be used in the performance of any warranty maintenance or repairs and must be provided without charge to the owner. Such use will not reduce the warranty obligations of the manufacturer.
- (10) Add-on or modified parts that are not exempted by the Air Resources Board may not be used. The use of any non-exempted add-on or modified parts by the ultimate purchaser will be grounds for disallowing a warranty claim.
- The manufacturer will not be liable to warrant failures of warranted parts caused by the use of a non-exempted add-on or modified part.

PARTS COVERED BY WARRANTY

Listed below are the parts (if equipped) covered by the Federal and California Emission Control System Warranty.

1. Ignition system including: <ul style="list-style-type: none">- Spark plugs- Ignition coils	4. Air induction system including: <ul style="list-style-type: none">- Intake pipe/manifold- Air cleaner
2. Fuel metering system: <ul style="list-style-type: none">- Fuel tank- Fuel cap- Fuel lines (for liquid fuel and fuel vapors) and related fittings/clamps- Fuel regulator, carburetor and internal parts.	5. Crankcase breather assembly including: <ul style="list-style-type: none">- Breather connection tube
3. Catalytic muffler assembly including: <ul style="list-style-type: none">- Exhaust manifold- Catalytic converter- Muffler gasket-pulse valve	6. Fuel tank evaporative emission control system including: <ul style="list-style-type: none">- Purge valves- Carbon canister- Vapor hoses and fitting/clamps

Limitations

This Emission Control System Warranty shall not cover any of the following:

- (a) Consequential damages such as loss of time, inconvenience, loss of use of the engine or equipment, etc.
- (b) Diagnosis and inspection fees that do not result in eligible warranty service being performed.

FIRMAN POWER EQUIPMENT INC.
www.firmanpowerequipment.com

FOLLOW US ON SOCIAL

USE

#EVERYGENERATORTELLSASTORY™

FOR YOUR CHANCE TO WIN FIRMAN SWAG



**FIRMAN POWER EQUIPMENT INC.
8644 W. LUDLOW DR.
WWW.FIRMANPOWEREQUIPMENT.COM
PEORIA, AZ 85381
1-844-347-6261**

All rights reserved. Any reprinting or unauthorized use without the written permission is expressly prohibited.
P/N:399745593 Rev:00