

Duro
NEXT GENERATION

Max
POWER SYSTEMS

Gasoline Water Pump Owner's Manual

XP652WP
XP650WP
XP904WP

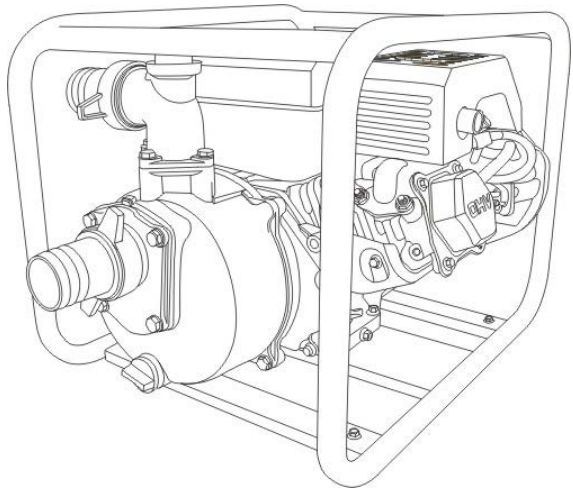

DuroMax Customer Service

info@duromaxpower.com or call 1-844-DUROMAX

Monday - Friday 7am to 5pm. PST

Product Support (Product: information, application & warranty questions)

support@duromaxpower.com or call 1-844-DUROMAX

Monday - Friday 7am to 5pm. PST

This manual provides information regarding the operation and maintenance of these products. We have made every effort to ensure the accuracy of the information in this manual. We reserve the right to change this product at any time without prior notice.

Please keep this manual available to all users during the entire life of the gasoline water pump.

CONTENTS

I . General Safeguards	1
II . Location of Component Parts	3
III. Operation before Starting Up	4
IV. Starting of Engine	9
V . Use in Highland Areas	11
VI. Operation of Water Pump	12
VII. Shutting Down the Engine	13
VIII. Maintenance	14
IX. Transportation and Storage	19
X . Troubleshooting	21
XI. Specifications	23

I . General Safeguards

Safety Precautions

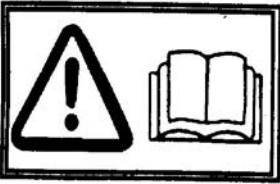

Please read this operation manual to have a thorough understanding of the content there before use the product. Failure to do so may lead to personal injury or mechanical damage.

Before starting the engine, perform inspections according to the procedures described on pre-operation inspections to avoid accidents and damage to your machine.

For safety, never attempt using this GEP (gasoline engine powered) water pump to deliver inflammable or corrosive liquids (such as gasoline and acids). Likewise, corrosive mediums, seawater, chemical solvents, alkaline liquids (such as used gasoline, liquor and honey) should be avoided.

Place the water pump on a solid, level position surface to avoid tilting or turnover that may give rise to spilling of fuel.

To prevent fire hazards, keep the pump well ventilated during operation and maintain a distance of at least 1 meter between the machine and the wall or other machines. Keep away from inflammable substances.

Do not allow children and pets to enter the working area as this may increase the chance of their getting burned by hot surfaces of the operating parts.

Know how to stop the water pump quickly how to operate the controls. Do not use the pump against the prescribed operating rules.

WARNING:

Safety Precautions

The gasoline fuel is highly inflammable and may explode under certain conditions.

Do the fueling with the engine shut down and in a well-ventilated

environment. No smoking is allowed and no open fire or sparks allowed to exist in areas where fueling is carried out or the fuel is stored.

Do not allow the fuel to overflow the fuel tank. Be sure to recap the tank and tighten it after refueling.

When fueling, take care not to spill the gasoline about as the gasoline vapor may easily get ignited to cause a fire hazard. Be sure to remove the spilled gasoline as by wiping before starting the engine.

Do not run the engine indoors or in a poorly ventilated space as the exhaust gas produced by the running engine contains toxic carbon monoxide that may cause the loss of personal consciousness or even death.

II. Location of Component Parts

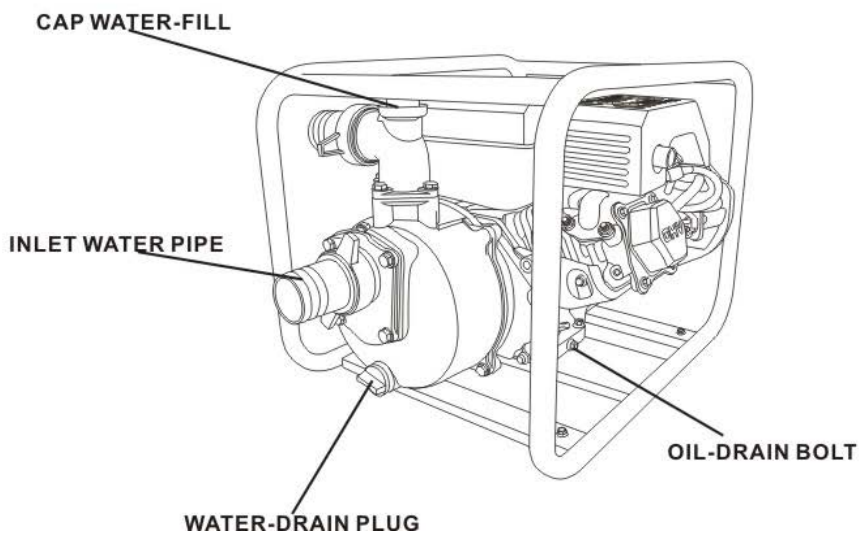
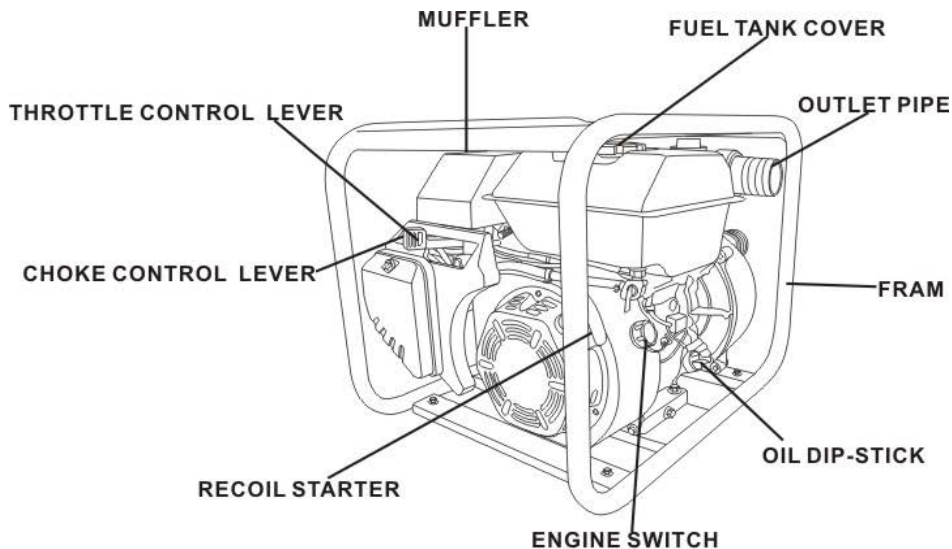

III. Operation before Starting Up

1. Connecting the water inlet

Connect the water inlet with a commercially available hose, connector and fastener clip. The inlet hose must be a continuous non-foldable structure with a length not more than required and should be placed near to the source of water so as to achieve the pump should be fitted to the end of the hose with the hose connector as shown in the figure below.

CAUTION: Before pumping water, attach the filter to the end of the hose to filter out foreign matters in the water, the presence of which may cause clogging and damage to the wane wheel.

NOTE: The hose connector and fastener clip should be securely fastened to prevent air leaks and reduction in suction power. A loose hose will reduce the pump performance and self-suction capacity.

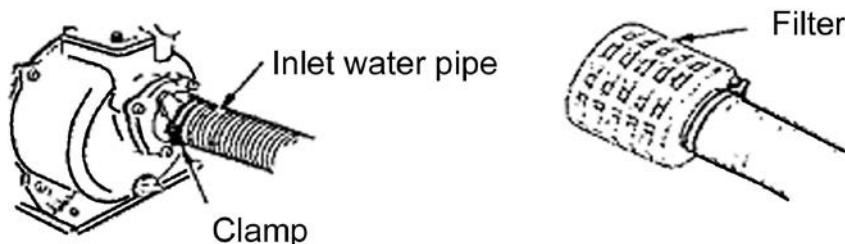

2. Connecting the water outlet

Connect the water outlet with a commercially available hose, hose connector and fastener clip. Large diameter hoses are the most effective while small ones will increase the flow resistance and reduce the output power of the pump.

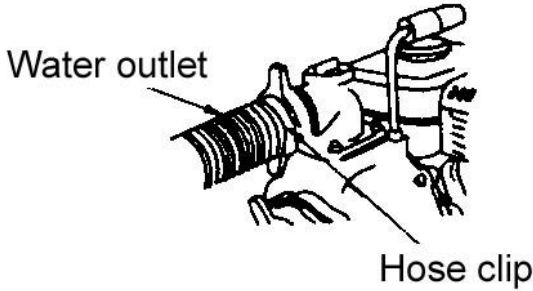

NOTE:

Be sure to the fastener clip is securely fastened to prevent the outlet hose from coming off under high water pressure.

3.Checking the oil level

CAUTION:

- The oil is one of the major factors affecting engine performance and life. Do not use dirty oil or vegetable oil.
- Be sure to check the oil level with the engine shut down and placed on a level surface.

Please use the SE15-40, 4-stroke engine oil as recommended.

Please use the type of oil with a proper viscosity according to the local average temperature.

Oil shortage alarm system (OSAS) (installation position)

The OSAS is designed to avoid damage of the engine due to the shortage of oil in the crankcase. The system will automatically shut down the engine just before the crankcase oil level drops down to the minimum line of safety (with the engine switch staying in the ON position).

If the engine is shut down and cannot be started again, check the oil level before initiating further troubleshooting procedures.

Remove the oil dipstick and wipe it dry.

Insert the dipstick into the oil filler but not screw it in.

Replenish the crankcase with the recommended type of oil until

the oil level comes up to the upper most position of the refilled if the existing oil level is found too low.

CAUTION:

- Running the engine at a low oil level will cause damage to it.

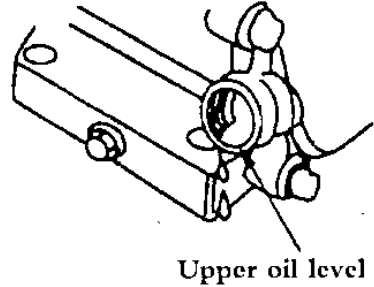
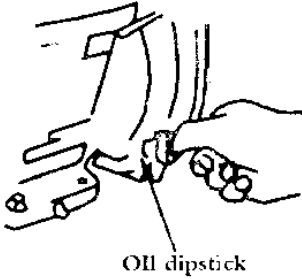

4. Checking the fuel level

Uncap the fuel tank and check the fuel level. Pouring gasoline if the fuel level is found too low.

Please use the type of gasoline recommended by the Dealer (Using the low lead content or lead-free gasoline type is good for minimizing carbon deposits inside the combustion chamber).

Do not use a mixture of gasoline and oil or dirty gasoline to prevent dirt, dust or water from entering the fuel tank.

CAUTION:

- The gasoline fuel is highly inflammable and may explode under certain conditions.
- Do the fueling with the engine shut down and in a well-ventilated environment. No smoking is allowed and no open fire or sparks allowed to exist in areas where fueling is carried out or the fuel is stored.
- Do not allow the fuel to overflow the fuel tank. Be sure to recap the tank and tighten it after refueling.

- When fueling, take care not to spill the gasoline about as the gasoline vapor may easily get ignited to cause a fire hazard. Be sure to remove the spilled gasoline as by wiping before starting the engine.

- Avoid frequent or extensive exposure of the skin to gasoline or breathing in the gasoline vapor. Keep the gasoline out of the reach of children.

- Fuel tank capacity: 1.0 gallons (US. 3.6 liters)



5. Checking the air cleaner filter element

Screw the wing nut and remove the washer and cleaner cover.

Check the filter element to see if it is too dirty and clean it if necessary.

CAUTION:

Do not run the engine without the air cleaner as this may quicken engine wear if dirt or dust is sucked into the engine through the carburetor.

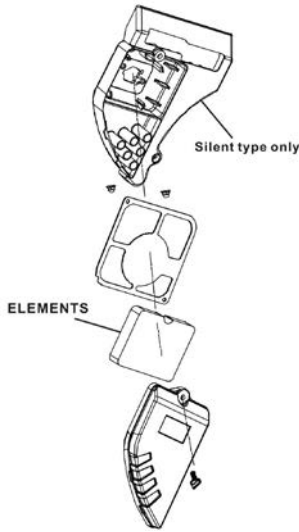

6. Checking and filling the pump with cooling water

The pump must be filled with water before it is put to operation.

CAUTION:

- Do not attempt running the pump without cooling water or the pump will get overheated. Extensive running without cooling water may also damage the air tightness of the pump. If the pump is found running dry, stop the engine and pouring in water when it cools down.

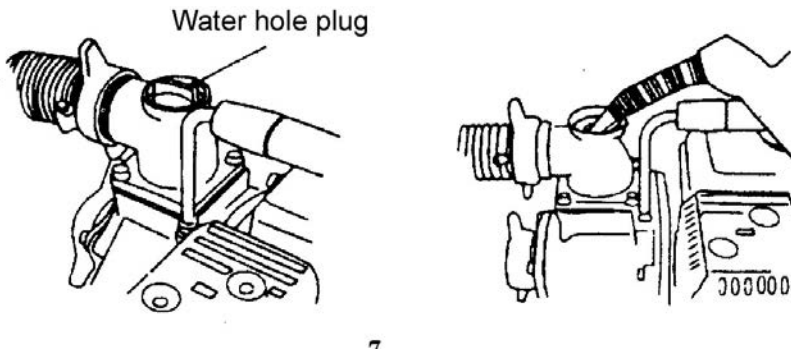

IV. Starting engine

1. Turn on the fuel tap (by setting it to the ON position).
2. Close the choke.

NOTE:

- The choke is not required when starting the engine warm or the ambient temperature is rather high, (i.e. keep the choke open when starting the engine).

3. Set the engine switch to the ON position.

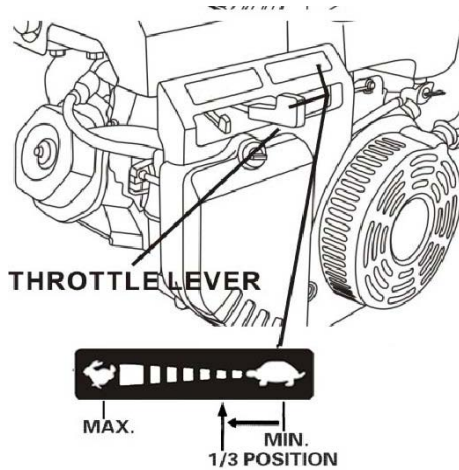

4. Turn the throttle control lever slowly to the left.

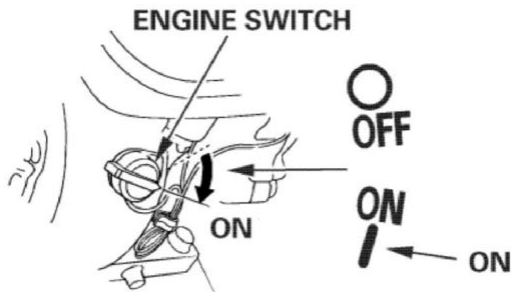

5. Gently pull up the starter lever until a resistance is felt and then quickly pull it up.

CAUTION:

•Do not allow the starter lever to retract quickly into the engine. Let it go back gently to avoid damaging the starter.

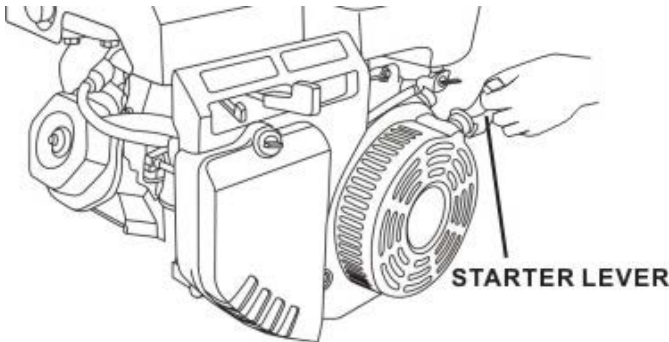

V .Use in Highland Areas

Operation in Highland Conditions

In highland areas (with a high ASL elevation), the air-fuel mixture produced by a standard carburetor will be too thick and result in a reduced engine performance and soared fuel consumption. For operation in highland areas, the engine performance may be increased by using a smaller diameter carburetor nozzle and readjusting the carburetor idle speed. If the water pump is frequently used in areas with a ASL elevation of more than 1800 meters (6000 feet), ask the local dealer to replace or readjust the carburetor beforehand. Even if the engine is fitted with a carburetor nozzle of an appropriate size, the engine power will still go down by about 3.5% each time when the ASL elevation goes up by 305 meters (1000 feet). If no replacement or readjustment is ever made of the carburetor, the highland effect of the engine output power will be even more obvious.

CAUTION:

- Using the water pump in areas where the ASL elevation is lower than suitable for the carburetor nozzle will lead to a decreased engine performance and overheating of the engine and even cause serious damage to the engine due to an extremely thin air-fuel mixture.

VI. Operation of the Water Pump

1. Gradually open the choke after the engine warms up.
2. Set the throttle to the predetermined RPM.

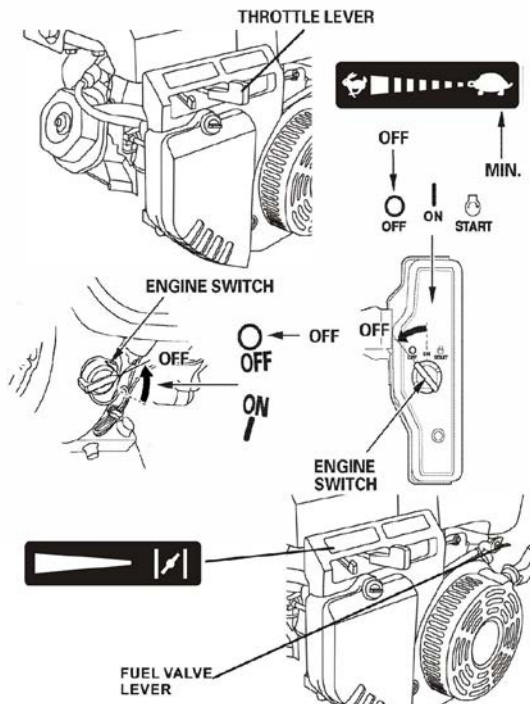

VII. Shutting Down the Engine

1. Set the throttle control lever to the right end.

2. Set the engine switch to the OFF position.
3. Turn off the fuel tap (by setting to the OFF position).

NOTE:

- To shut down the engine in an emergency, simply set the engine switch to the OFF position.

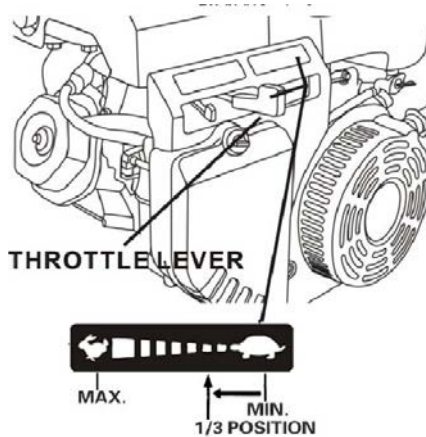

VIII. Maintenance

Periodic inspections and fine-tuning are simply indispensable to keep the water pump working with high performance and regular maintenance may also lengthen the pump life. Supplied in the table on the next page are intervals at which the schedules maintenance jobs are to be done.

WARNING:

- Before any maintenance attempt, be sure to shut down the engine. If the maintenance job has to be done with the engine at work, it should take place in a well-ventilated space as the exhaust gas contains toxic carbon monoxide that causes the loss of personal consciousness or even death.

CAUTION:

- In cases when the pump is used to suck up seawater, be sure to flush it with fresh water immediately after use to minimize corrosion and remove deposits.
- Always use the original parts and relevant tools supplied with the machine to carry out maintenance. Failure to do this may cause damage to the pump.

NOTE:

- (1) Inspection and maintenance should take place more frequently if the pump is used in a dirty environment.
- (2) Leave the following inspection and maintenance jobs to the authorized dealers unless you, the user, have the relevant tools and necessary DIY skills. In the latter case, refer to service manual.

Table of Maintenance Schedules

Item	Normal maintenance period	Each time	Per month or 20 hours	Per month or 50 hours	Per month or 100 hours	Per month or 300 hours
Check engine oil lever		○				
Replace engine oil lever			○		○	
Air cleaner check		○				
Air cleaner for clean						
Spark plug				○		○*
Fuel supply	Replace per every two years					
Wane wheel						○*
Pump case cover						○*

Note: “*” items will be maintained with the help of dealers from general power machinery Co., Ltd.

1. Replacing the engine oil

Oil drains easily and quickly while the engine is warm.

1. Remove the oil dipstick and drain bolt to let out the oil.
2. Screw the drain bolt back in place and tighten it.
3. Pour in clean oil until the desired level is reached.

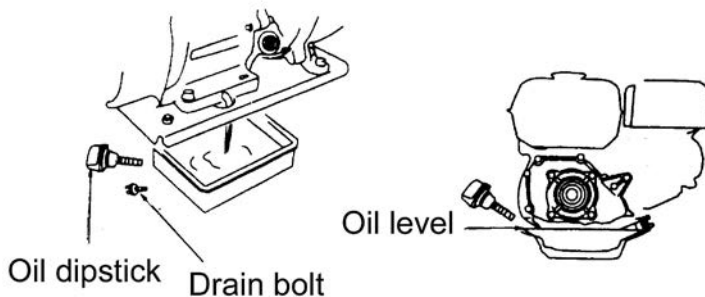

Oil sump capacity: 0.6 liters

Clean the hands with soap if stained with the engine oil.

NOTE: Be sure to keep the environment clean when disposing used engine oil. We suggest you collect the waste oil in a container to be sent to a waste disposal site or a recycling service center or spill it in the garbage or on the ground.

2. Maintaining the air cleaner

A dirty air cleaner will let less air into the carburetor. To prevent carburetor malfunctions, be sure to maintain the air cleaner periodically. More frequent maintenance of the air cleaner will be necessary if the pump is working in an extremely dirty environment.

DO not clean the air cleaner with a low ignition point solvent because it may get enflamed or even explode under certain

circumstances.

CAUTION: Do not use the water pump without an air cleaner. The dirt or dust if sucked into the engine may quicken engine wear.

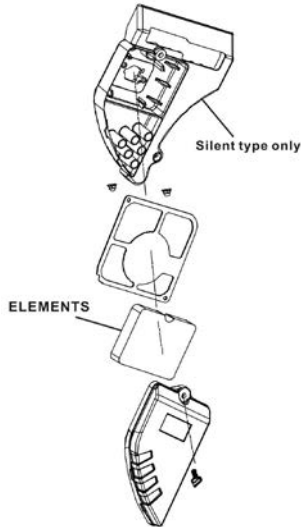

1) Unscrew the wing nut and remove the air cleaner cover and filter element.

2) Clean the filter element with a detergent solution inflammable or with a high ignition point and let it dry thoroughly after cleaning.

3) Immerse the filter element into clean oil and then squeeze out the excessive amount of oil.

4) Put the filter element as well as the air cleaner back in place.

3. Maintaining the spark plug

The recommended type of spark plug is NHSP LD P6RTC.

To ensure normal operation of the engine, the spark plug should have a correct gap and should remain free of carbon deposits.

1) Remove the plug cap.

The muffler may be very hot if the engine is still running. Take care not to touch the muffler.

2) Check the spark plug visually. Discard the spark plug if it is

obviously worn out or the insulation ring on it is broken or cracked. Clean the spark plug with a brush when put it back in place.

3) Check the plug gap with a feeler gauge.

Vary the gap by moving the side electrode.

Normal plug gap: 0.70~0.80mm

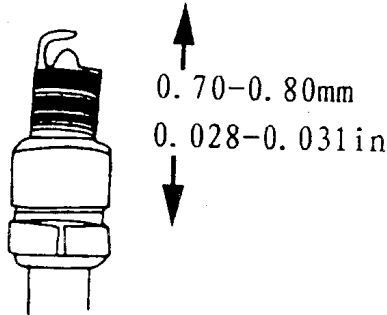

4) Check the plug O-ring for normal condition. Screw it in with the plug wrench to protect the plug thread.

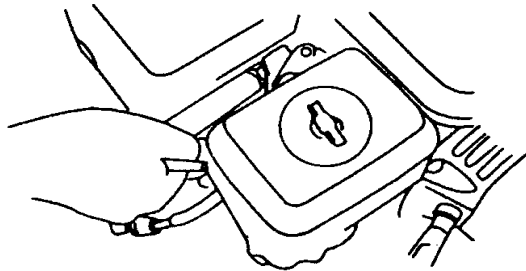

NOTE:

- In the case of screwing in a new spark plug, tighten it by an additional 1/2 screw turn after the plug reaches and pushes on the O-ring, while in the case of a used spark plug, an additional 1/2~1/4 screw turn is necessary.

CAUTION:

- Make sure the spark plug is properly tightened. Improper

tightening may cause the engine to be overheated or damaged. Never use spark plugs with an incorrect thermal value range.

IX. Transportation and Storage

CAUTION:

- To avoid causing a fire hazard, let the engine cool down before transportation or indoor storage of the pump.

- Before transporting the pump, set the fuel tap to the OFF position and place the pump body in a level position to prevent the fuel from spilling out. The spilled gasoline or the gasoline vapor may get ignited.

Note and do the following before storing pump for an extended period of time:

- 1) Make sure the storage area is free of moisture or dust.

- 2) Clean the inside of the pump.

The pump may get clogged if it is used to suck up water containing such matters as earth, sand or heavy fragments.

Before storing, clean the pump by sucking up clean water or otherwise the vane wheel may be damaged when the pump is put to use again. After cleaning, unscrew the water drain plug to drain off the water from inside the pump casing as much as possible. Then screw the drain plug back into place.

- 3) Drain off the fuel.

- a. Turn off the fuel tap (OFF position), unscrew the drain screw from the carburetor float chamber to drain off the fuel from inside the carburetor and collect the gasoline in a suitable container.

- b. Turn on the fuel tap (ON position) and collect the gasoline in a suitable container.

- c. Screw the carburetor fuel drain screw back into place.

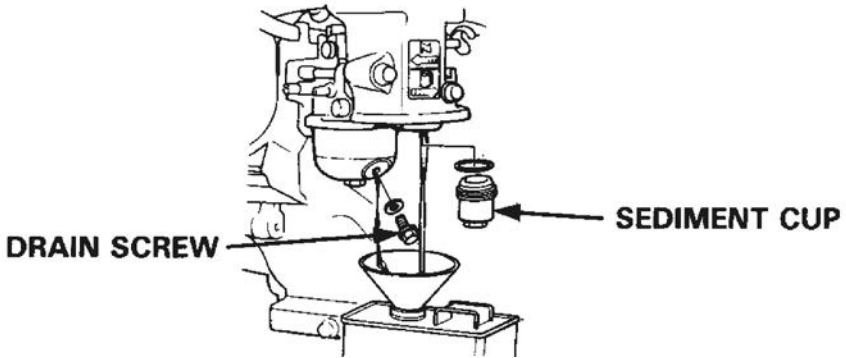

4) Replace the engine oil.

5) Screw off the spark plug, pour a spoonful of clean oil into the cylinder, turn the engine alternatively for several times to allow uniform distribution of oil, and then screw in the spark plug again.

6) Pull up the starter lever until a resistance is felt. Stop pull for a while and pull it up again until the triangle mark on the starter wheel gets into collimation with the screw hole in the starter (as shown the sketch below). In this position, both the inlet valve and outlet valve is closed to prevent corrosion inside the engine.

7) Cover up the pump to keep out dust.

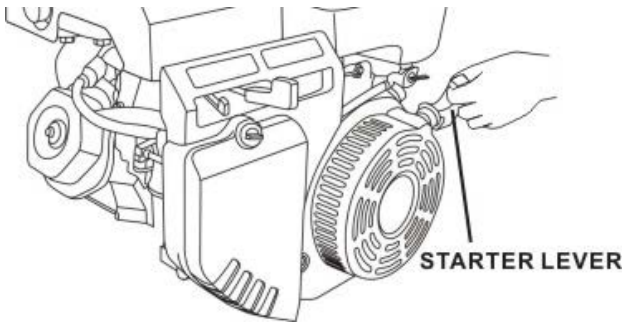

X. Troubleshooting

Engine unable to get started:

- 1) Is there enough fuel?
- 2) Is the fuel tap turned on?

3) Has the fuel reached the carburetor? Make the check by unscrewing the oil drain screw from under the carburetor with the fuel tap turned on.

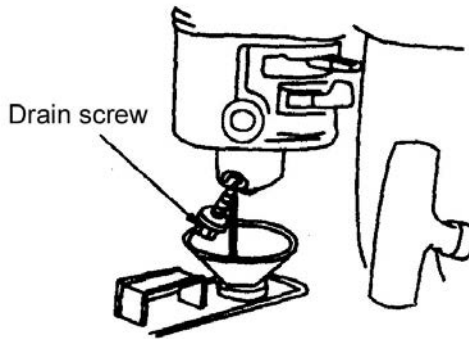

WARNING:

• Should there be a spill of fuel, be sure to clean it before checking the spark plug and start the engine or otherwise the spilled fuel or fuel vapor may get ignited

4) Is the engine switch set to the ON position?

5) Is there enough oil in the crankcase?

6) Is the spark plug generating sparks?

a. Uncap the spark plug, clear off the dirt from around the plug and remove the spark plug.

b. Fit the spark plug into the plug cap.

c. Turn on the engine with the side electrode and pull up the starter lever to see if there is sparks generated.

d. Ground the engine with the side electrode and pull up the starter lever to see if there is sparks generated.

e. Replace the spark plug if no spark is found.

Start the engine as directed in the operation manual if sparks are generated.

7) If the engine still refuses to get started, send the pump to any of the authorized dealers.

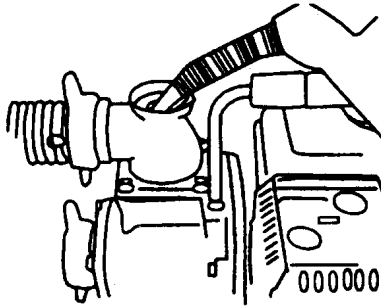

The pump unable to such up water:

- 1) Is it filled with enough amount of water?
- 2) Is the filter clogged?
- 3) Is the hose fastener clip tightened?
- 4) Is the hose damaged?
- 5) Is the suction head too high?
- 6) If the pump still fails to work, send it to any of the authorized dealers.

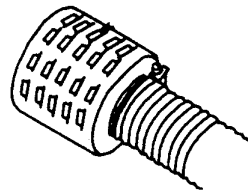
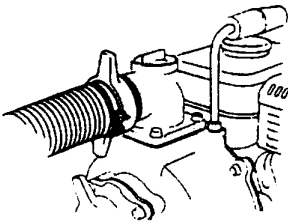

XI. Specifications

Type	XP652WP	XP650WP	XP904WP
Engine type	XP6.5HP	XP6.5HP	XP9.0HP
Max. Power	4.7kw(7HP)	4.7kw(7HP)	6.5kw(9.0HP)
Displacement	208cc	208cc	270cc
Fuel tank capacity	1.0 Gallons	1.0 Gallons	1.7 Gallons
Oil capacity	0.63 US. Qt.	0.63 US. Qt.	1.16 US. Qt.

Water intake pipe dia.	2"	3"	4"
Water output pipe dia.	2"	3"	4"
Revolution	3600rpm	3600rpm	3600rpm
Max. overhead lift	92ft	98ft	98ft
Max. suction lift	26ft	26ft	26ft
Max. flow rate	158 GPM	220 GPM	427 GPM
Size	18.7×15.6× 15.4(in.)	21.3×17.5× 19.3(in.)	25.2×20.7× 22.3(in.)

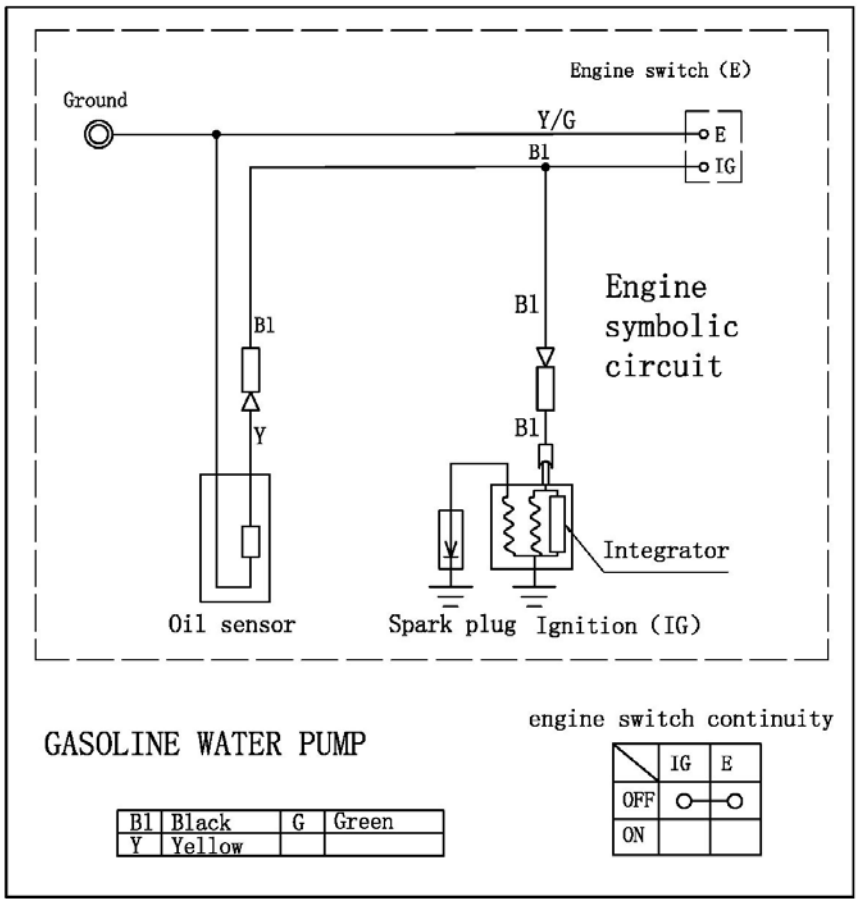

PARTS LIST AND ASSEMBLY (XP652WP/XP650WP)

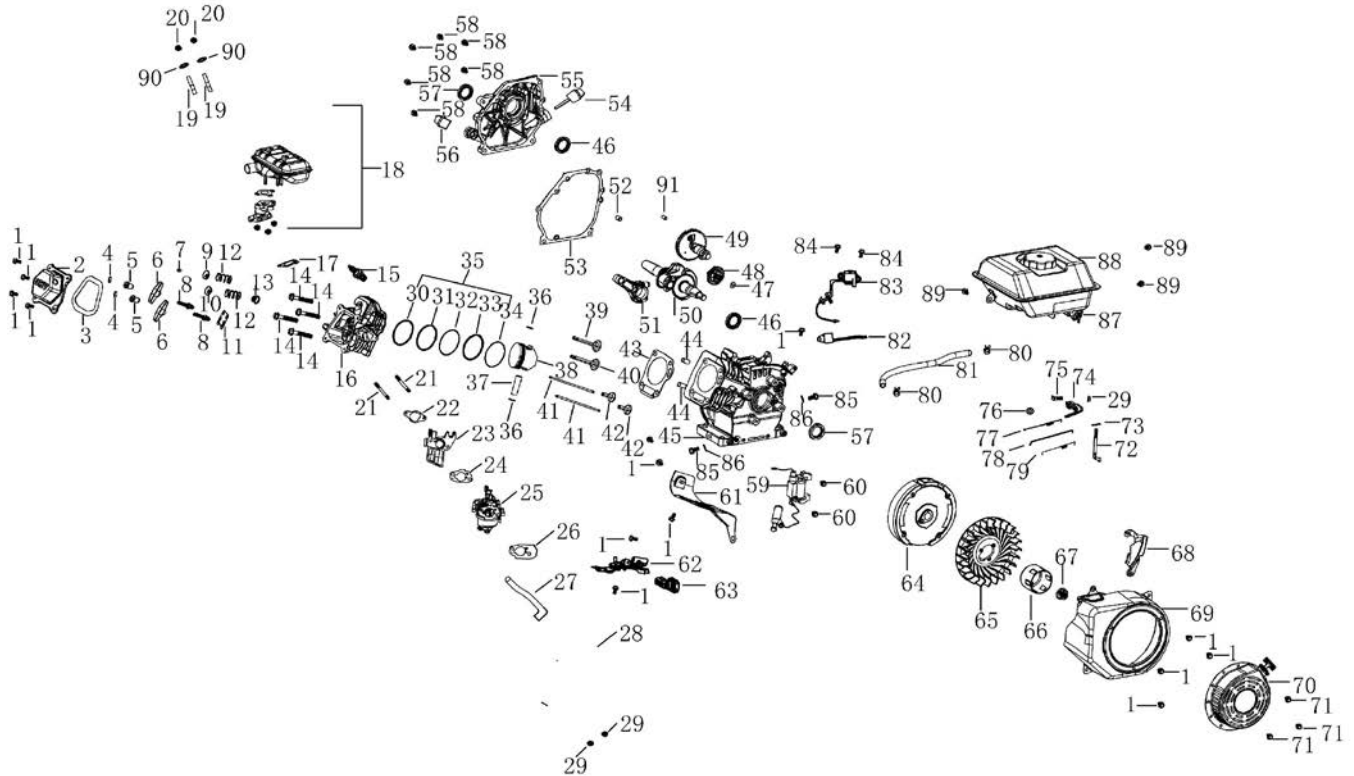

Item	Part	Qty	Description	Item	Part	Qty	Description
1	GBT5789-86	13	Flange bolt M6x12	45	DJ170F-11100-C	1	Crank case assy.
2	DJ168F-11300-B	1	Cover assembly	46	GB276-89-6205	2	Radial ball bearing (6025)
3	DJ168F-11011-A	1	cover assembly	47	DJ168F-15100-A	1	Speed Regulating Gear
4	DJ168F-13204-A	1	Lock Nut	48	DJ168F-15100-A	1	centrifugal assy.
5	DJ168F-13203-A	1	Adjusting Nut	49	DJ168F-13100-B	1	Camshaft assy.
6	DJ168F-13201-A	1	Arm, valve rocker	50	DJ168F-12100-W	1	Crankshaft Assembly
7	DJ168F-13006-A	1	Rotator, valve	51	DJ170F-12200-B	1	Tie-rod Assembly
8	DJ168F-13202-A	2	Fastening Bolt	52	DJ168F-11002-D	1	Pin, dowel, 7x12
9	DJ168F-13005-A	1	Retainer, EX. Valve spring	53	DJ170F-11003-B	1	Crankcase Gasket
10	DJ168F-13004-A	1	Retainer, IN. Valve spring	54	DJ168F-11007-A	1	Oil Filler Assembly
11	DJ168F-13300-A	1	Plate, push rod guide	55	DJ168F-11001-C	1	Crankcase cover
12	DJ168F-13003-A	2	Spring, valve	56	DJ168F-11600-A	1	Dipstick cover

13	DJ168F-13010-A	1	Returnrer, Exhaust Valve	57	DJ168F-11014-A	2	Oil seal, 25.14x35x7
14	GBT5787-B8-60	4	Flange bolt M8x60	58	GBT5787-B8-35	6	bolt M8x35
15	DJ168F-18500-B	1	Spark Plug F7TC	59	DJ168F-18100-C	1	Ignition Coil
16	DJ170F-11200-B	1	Head comp, cylinder	60	GBT5787-B6-25	2	bolt M6x25
17	DJ168F-14006-C	1	Outlet Gasket	61	DJ168F-11012-A	1	Air-leading Cover
18	DJ170N-14400-A	1	Muffer Assembly	62	DJ170N-15200-A	1	speed adjuster
19	DJ168F-14002-A	2	Bolt head, M8x35	63	DJ170N-15201-A	1	Speed Regulating Bar
20	GBT6177-N-8	2	Flange nut M8	64	DJ168F-16200-C	1	Flywheel
21	DJ168F-14001-A	2	Bolt Stud, 6x90	65	DJ168F-16002-A	1	Flywheel Fan
22	DJ168F-14003-B	1	Inlet Gasket	66	DJ168F-16000-A	1	Starting Cup
23	DJ168F-14004-A	1	Connecting Block,Carbretor	67	GBT6177-N-14	1	Flange nut M14
24	DJ168F-14005-A	1	Carbretor Gasket	68	DJ168F-11400-A	1	Wind Shiel Assembly
25	DJ170N-14100-A	1	Carburetor Assembly	69	DJ170N-16121-A	1	Recoil Sarer

26	DJ168F-14027-A	1	Air Cleaner Gasket	70	DJ170N-16122-A	1	recoil starter
27	DJ170N-11013-A	1	Tube, Breather	71	GBT5787-B6-8	3	Bolt Flange M6×8
28	DJ170N-11420-A	1	AirCleaner Assembly	72	DJ168F-15001-A	1	Shaft, governor assy.
29	GBT6177-N-8	2	Flange nut M8	73	DJ168F-15003-A	1	Pin Lock
30	DJ170F-12301-A	4	Piston Ring A	74	DJ168F-15004-A	1	Speed Regulating Arm
31	DJ170F-12302-A	1	Piston Ring B	75	DJ168F-15005-A	1	Lock Bolt
32	DJ170F-12304-A	1	Side Ring	76	GBT6177-N-6	3	Flange nut M6
33	DJ170F-12303-A	1	Wave Ring	77	DJ170F-15007-B	1	Back Spring B
34	DJ170F-12304-A	1	Side Ring	78	DJ168F-15006-A	1	Pulling Rod
35	DJ170F-12300-A	1	Scrapper Ring Set, Piston	79	DJ170F-15008-A	1	Fine Regulating Spring C
36	DJ168F-12003-A	2	Clip, piston pin	80	DJ1P65F-14008-A	2	Tube clip
37	DJ170F-12002-A	1	Pin, piston	81	DJ170N-14007-A	1	Outlet pipeφ6×φ10×295
38	DJ170F-12001-B	1	Piston	82	DJ168F-18300-A	1	Amplifier
39	DJ168F-13002-A	1	Intake Valve	83	DJ168F-18200-A	1	Oil Sensor Assembly

40	DJ168F-13001-A	1	Exhaust Valve	84	GBT5787-B6-16	2	bolt M6x16
41	DJ170F-13008-A	2	Rod, push	85	DJ168F-11004-A	2	Drain Plug Washer
42	DJ170F-13009-A	2	Tappet Litter Valve	86	DJ168F-11005-A	2	Washer, drain lug
43	DJ170F-11010-C	1	Casket, cylinder head	87	DJ170N-14302-A	1	Fuel cock
44	DJ168F-11009-A	2	Set Pin, 10x14	88	DJ170N-14300-A	1	Fuel tank
89	GBT5787-B6-16	3	bolt M6x16	90	GBT93-LW-8	2	spring washer

XP652WP

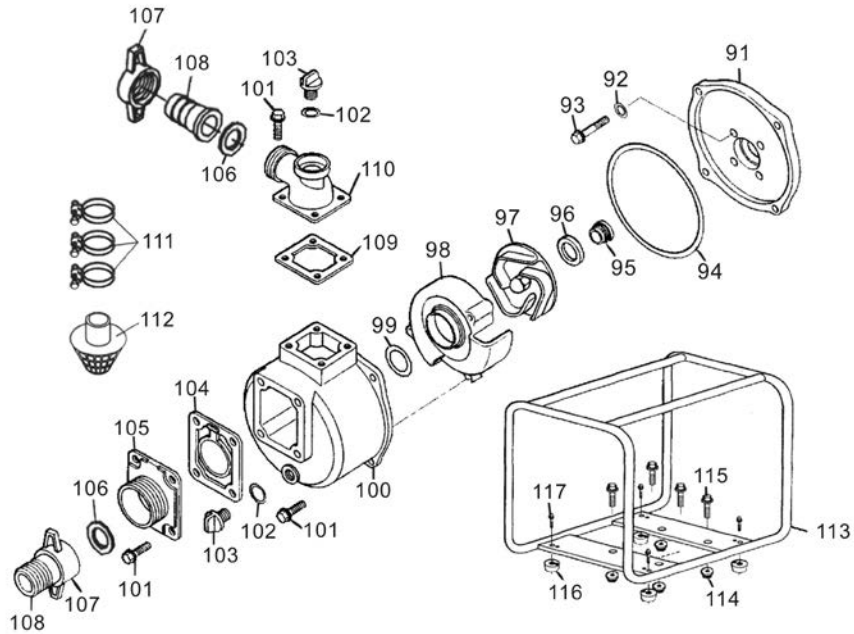

Item	Part	Qty	Description	Item	Part	Qty	Description
91	DS20-32001-A	1	Casing	105	DS20-32003-A	1	Suction port
92	GB97.1-W-8	4	Gasket, Φ 8x1.6,	106	DS20-32008-A	2	Coupling Packing
93	GB70-B8-60	4	Flange Bolt M8x60	107	DS20-32010-A	2	Hose Joint
94	DS20-32052-A	1	Casing Gasket	108	DS20-32200-A	2	Hose Coupling
95	DS20-32013-A	1	Mechanical seal A	109	DS20-32009-A	1	Discharge gasket
96	DS20-32013-B	1	Mechanical seal B	110	DS20-32004-A	1	Discharge port
97	DS20-32005-A	1	Impeller	111	DS20-32016-A	3	Hose Band
98	DS20-32006-A	1	Case Volute	112	DS20-32020-A	1	Strainer
99	DS20-32011-A	1	O-ring seal	113	XP652WP-31100-A	1	Frame
100	DS20-32002-A	1	Pump case housing	114	GB6177-N8	4	Flange nut M8
101	GB5787-B8-25	12	Flange Bolt M8x25	115	GB5787-B8-35	4	Flange bolt M8x35
102	DS20-32050-A	2	O-ring, Plug	116	DS20-31203-A	4	Rubber pad, damping
103	DS20-32049-A	2	Plug	117	GB5787-86	4	Flange Bolt M6x12
104	DS20-32030-A	1	Flapper valve gasket				

XP650WP

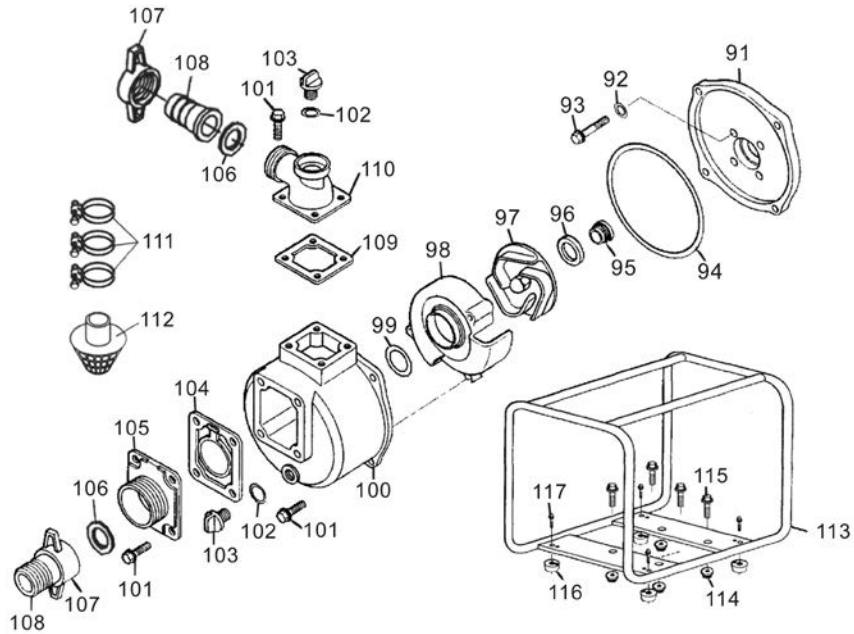

Item	Part	Qty	Description	Item	Part	Qty	Description
91	DS30-32001-A	1	Casing	105	DS30-32003-A	1	Suction port
92	GB97.1-W-8	4	Gasket Φ 8x1.6	106	DS30-32008-A	2	Coupling Packing
93	GB70-B8-60	4	Flange Bolt M8x60	107	DS30-32010-A	2	Hose Joint
94	DS30-32052-A	1	Casing Gasket	108	DS30-32200-A	2	Hose Coupling
95	DS30-32013-A	1	Mechanical seal A	109	DS30-32009-A	1	Discharge gasket
96	DS30-32013-B	1	Mechanical seal B	110	DS30-32004-A	1	Discharge port
97	DS30-32005-A	1	Impeller	111	DS30-32016-A	3	Hose Band
98	DS30-32006-A	1	Case Volute	112	DS30-32020-A	1	Strainer
99	DS30-32011-A	1	O-Ring Seal	113	XP650WP-31100 -A	1	Frame
100	DS30-32002-A	1	Pump case housing	114	GB6177-N8	4	Flange nut M8
101	GB5787-B8-25	12	Flange Bolt M8x25	115	GB5787-B8-35	4	Flange bolt M8x35
102	DS30-32050-A	2	O-ring, Plug	116	DS20-31203-A	4	Rubber pad, damping
103	DS30-32049-A	2	Plug	117	GB5787-B6-12	4	Flange Bolt M6x12
104	DS30-32030-A	1	Flapper valve gasket				

PARTS LIST AND ASSEMBLY(XP904WP)

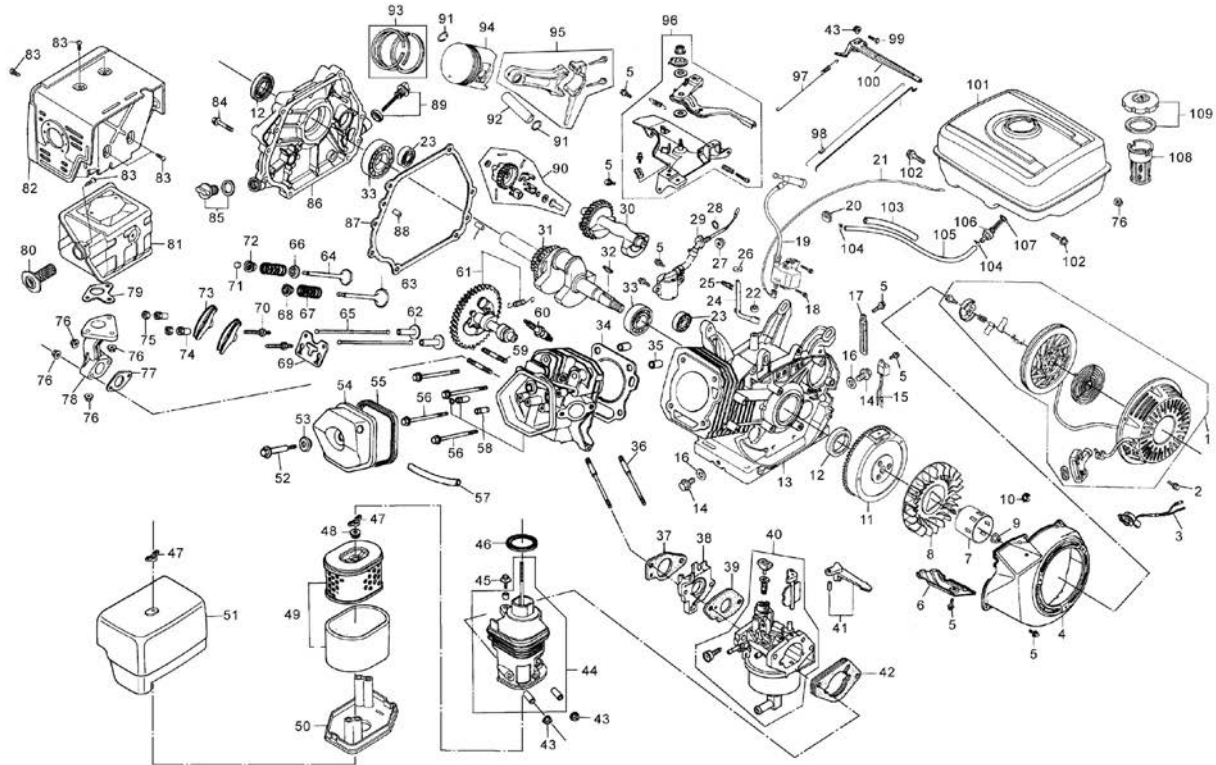

Item	Part	Qty	Description	Item	Part	Qty	Description
1	16102	1	Starter comp, recoil	21	18105	1	Cord stop switch
2	GB5787-86	3	Flange bolt M6×8	22	15009		Oil seal, 8×14×5
3	18400	1	Engine switch	23	GB/T276-94	2	Radial ball bearing (6202)
4	16103	1	Fan, cover comp	24	15001	1	Shaft, governor arm
5	GB5787-86	12	Flange bolt M6×12	25	15003	1	Pin, lock, 10mm
6	11012	1	Shroud comp	26	15002	1	Washer, 8.2×17×0.8
7	16001	1	Pulley, starter	27	GB6177-86	1	Flange nut M10
8	16002	1	Fan, cooling	28	18201	1	O-ring, 14mm
9	GB6177-86	1	Flange nut M16	29	18200	1	Switch assy. oil level
10	11039	1	Clip. Wire harness	30	12004	1	Weight, balancer
11	16200	1	Flywheel comp	31	12100	1	Crankshaft comp
12	11014	2	Oil seal, 35×52×8	32	GB/T 99-88	1	Key
13	11100	1	Crank case assy.	33	GB/T276-94	2	Radial ball bearing (6207)
14	11004	2	Bolt, drain lug	34	11010	1	Casket, cylinder head
15	18300	1	Amplifier	35	11009	2	Pin, dowel, 12×20
16	11005	2	Washer, drain lug	36	14001	2	Bolt head, 8×111
17	18009	1	Clip, wire	37	14003	1	Packing, insulator

18	GB5789-86	2	Flange bolt M6×25	38	14004	1	Insulator, carburetor
19	18100	1	Coil assy. ignition	39	14005	1	Packing, carburetor
20	11017	1	Grommet cord	40	14100	1	Carburetor assy.
41	14113	1	Stay manual choke	63	13001	1	Valve, IN.
42	14207	2	Packing, air cleaner	64	13002	1	Valve, EX.
43	GB6177-86	5	Flange nut M6	65	13008	2	Rod, push
44	14208	1	Case comp, air cleaner	66	13007	1	Seat, valve spring
45	GB5789-86	1	Flange bolt M6×20	67	13003	2	Spring, valve
46	14206	1	Seal, air cleaner	68	13004	1	Retainer, IN. Valve spring
47	14212	2	Nut, M6	69	13300	1	Plate, push rod guide
48	14209	2	Washer, drain lug	70	13202	2	Bolt, pivot
49	14201	1	Element assy. air cleaner	71	13006	1	Rotator, valve
50	14203	1	Separator, air cleaner	72	13005	1	Retainer, EX. Valve spring
51	14204	1	Cover comp, air cleaner	73	13201	2	Arm, valve rocker
52	11015	1	Bolt, head cover	74	13203	2	Nut, Arm, valve rocker
53	11016	1	Washer comp head cover	75	13204	2	Nut, pivot adjusting
54	11300	1	Cover comp, head	76	GB6177-86	6	Flange nut M8
55	11011	1	Exhaust piper	77	14006	1	Casket (B) EX. Pipe
56	GB5789-86	4	Flange bolt M10×80	78	14009	1	Pipe comp EX.
57	11013	1	Tube, breather	79	14010	1	Muffler stay

58	11201	1	Head comp, cylinder	80	14406	1	Arrester, spark
59	14002	2	Bolt head, M8x34	81	14400	1	Muffler
60	18500	1	Plug, spark	82	14417	1	Muffler guard
61	13101	1	Camshaft assy.	83	GB847-85	5	Screw, tapping M5x8
62	13009	2	Lifter, valve	84	GB5789-86	7	Flange bolt M8x35
85	11006	1	Cap, oil hole	98	15008	1	Spring, throttle return
86	11001	1	Crankcase cover	99	15005	1	Bolt, governor arm
87	11003	1	Packing, case cover	100	15004	1	Arm, governor
88	11002	2	Pin, dowel, 8x12	101	14300	1	Fuel tank
89	11007	1	Cap assy. oil filler	102	GB5789-86	2	Flange bolt M8x25
90	15100	1	Governor kit	103	11013	1	Rubber, supporter
91	12003	2	Clip, piston pin	104	14008	1	Fuel cock
92	12002	1	Pin, piston	105	14007	1	Outlet pipe ϕ 4.5x235
93	12300	1	Ping set assy. piston	106	14026	1	Joint, fuel tank
94	12001	1	Piston	107	14311	1	Rubber joint, fuel tank
95	12200	1	Connecting rod assy.	108	14307	1	Fuel filter
96	15200	1	Control assy.	109	14306	1	Fuel filler cap comp
97	15007	1	Spring, governor				

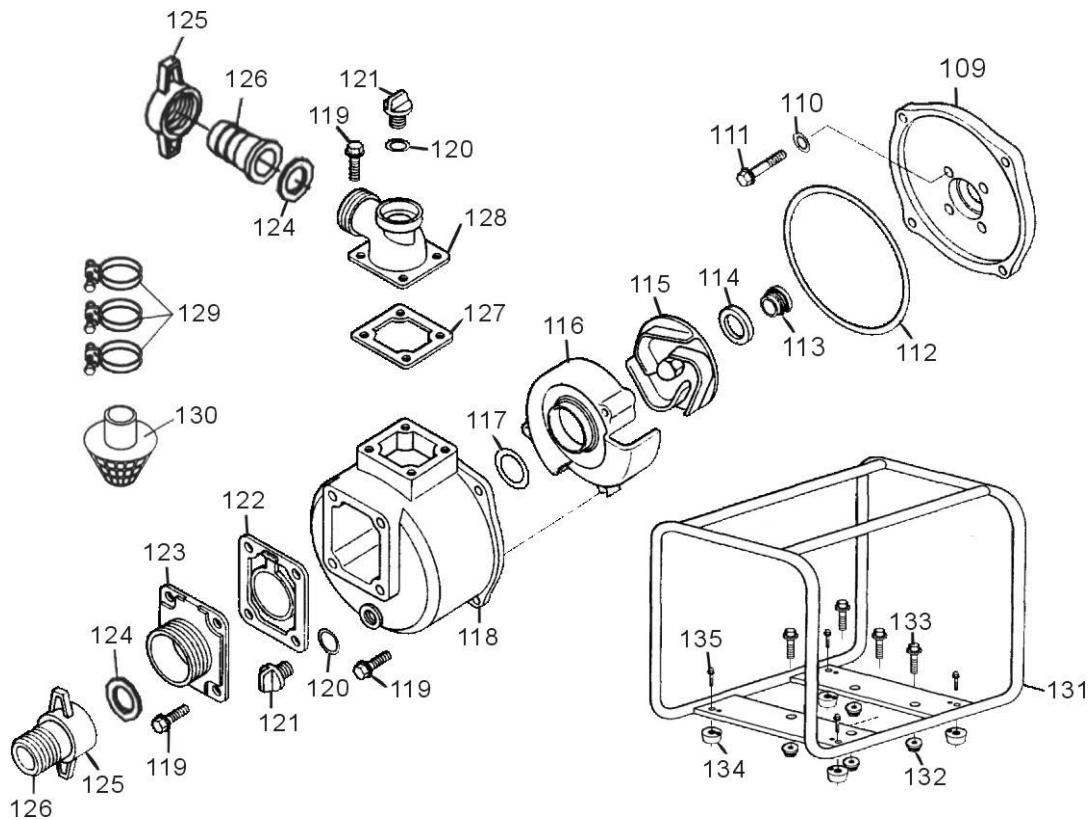

ITEM	PART	QTY	DESCRIPTION	ITEM	PART	QTY	DESCRIPTION
109	DS40-32001	1	ASSEMBLY, PUMP COVER	123	DS40-32003	1	SUCTION PORT
110	DS40-32015	4	WASHER	124	DS40-32008	2	COUPLING PACKING
111	GB5787-86	4	FLANGE BOLT M8X45	125	DS40-32010	2	HOSE JOINT
112	DS40-32012	1	O-RING, WATER PUMP	126	DS40-32200	2	HOSE COUPLING
113	DS40-30258	1	MECHANICAL SEAL A	127	DS40-32009	1	DISCHARGE GASKET
114	DS40-32038	1	MECHANICAL SEAL B	128	DS40-32004	1	DISCHARGE PORT
115	DS40-32005	1	IMPELLER, WATER PUMP	129	DS40-32016	3	HOSE BAND
116	DS40-32006	1	VOLUTE CASING	130	DS40-32020	1	STRAINER
117	DS40-32011	1	RING, VOLUTE CASING	131	DS40-31100	1	FRAME
118	DS40-32002	1	PUMP CASE HOUSING	132	GB6177-86	4	FLANGE NUT M10
119	GB5787-86	12	FLANGE BOLT M10X25	133	GB5789-86	4	FLANGE BOLT M10X35
120	DS40-32050	2	O-RING, PLUG	134	DS40-31203	4	RUBBER PAD, DAMPING
121	DS40-32049	2	PLUG	135	GB5787-86	4	FLANGE BOLT M6X16
122	DS40-32030	1	FLAPPER VALVE GASKET				