

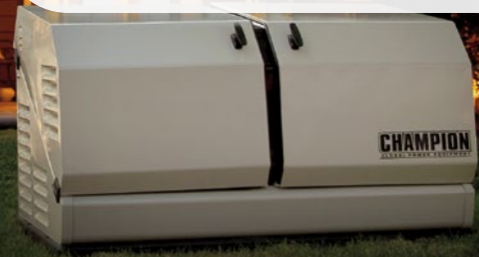

50-200 Amp

**Automatic Transfer Switches (ATS)
Load Control Module (LCM)**

Champion's family of automatic transfer switches (ATS) and load control module (LCM) give you options that range from 50 Amp Emergency Essentials to 200 Amp Whole House solutions.



The **SIMPLE SOLUTION**[™]

There are **TWO WAYS** to control power distribution in your home:



or



With our **EMERGENCY ESSENTIALS** switches (available in either 50 Amp or 100 Amp options), this allows you to use only the key appliances you select during a power outage, determined at the time of your initial installation. Emergency Essentials is the cost effective way to power the most important circuits in your home when the power goes out.

With our **WHOLE HOUSE** with **DEMAND CONTROL** (available only in a 200 Amp option) intelligent load management technology, your home's power requirements are monitored continuously. This ATS can back up your home's entire 200 Amp distribution panel with the ability to manage up to 8 high demand appliances for your Whole House power needs. Your home's circuits are divided into prioritized zones – from vital to managed. If your generator nears maximum capacity, pre-designated, high demand appliances are managed to avoid overload. As soon as demand lowers, the generator will automatically reacquire the appliances that are managed. Appliances are managed and reacquired sequentially.

A **LOAD CONTROL MODULE** (sold separately) is used for larger loads such as electric range, dryer or water heater. When choosing a smaller generator for your Whole House needs, Demand Control means that you do not always need to choose the largest generator.

It's your **choice...**

...do you want **EMERGENCY ESSENTIALS** or **WHOLE HOUSE** with **DEMAND CONTROL** 





Model	Generator	ATS	Output (Propane/NG)	Engine
100199	8.5 kW	Generator only	8,500W 7,500W	439cc Champion OHV
100174		ATS50 Emergency Essentials switch (NEMA 1)		
100177		ATS50 Emergency Essentials switch (NEMA 3R)		
100136	12.5 kW	Generator only	12,500W 11,000W	717cc V-twin Champion OHV
100176		ATS100 Emergency Essentials switch (NEMA 1)		
100179		ATS100 Emergency Essentials switch (NEMA 3R)		
100291		ATS200 Whole House switch with Demand Control (NEMA 3R service entry)		
100237	14 kW	Generator only	14,000W 12,500W	754cc V-twin Champion OHV
100295		ATS100 Emergency Essentials switch (NEMA 1)		
100292		ATS100 Emergency Essentials switch (NEMA 3R)		
100294		ATS200 Whole House with Demand Control switch (NEMA 3R service entry)		



Locate a certified Champion Home Standby Dealer and Installer by visiting:
www.championpowerequipment.com or emailing hsb@cpeauto.com

Champion Power Equipment, Inc.
12039 Smith Ave. – Santa Fe Springs, CA 90670 – USA
hsb@cpeauto.com – 1-877-338-0999

AUTOMATIC TRANSFER SWITCHES (ATS) / LOAD CONTROL MODULE (LCM)

ATS/LCM SPECIFICATIONS	ATS 50	ATS 100	ATS 200	LCM 50
Application	 EMERGENCY ESSENTIALS (for select circuit installation only)	 EMERGENCY ESSENTIALS (for select circuit installation only)	 WHOLE HOUSE (intelligent load management for up to 8 appliances)	 Manage up to 50 amp load (sold separately)
Voltage (single phase)	120/240			
Amperage	50	99	200	50
Service entry rated	No	No	Yes	–
Available Circuits	8	12	Whole House	–
Frequency AC	60 Hz			
Certification	UL and cUL			
Indoor rated NEMA 1 enclosure model #	100947	100949	–	–
> Dimensions (L[D] x W x H)	4.5 x 12.5 x 22.25 in.	4.5 x 12.5 x 22.25 in.	–	–
> Weight	21 lb.	22 lb.	–	–
Outdoor/Indoor rated nema 3R enclosure model #	100950	100952	101380	100323
> Dimensions (L[D] x W x H)	5 x 13 x 23 in.	3.5 x 22.25 x 12.75 in.	6.25 x 18 x 23.25 in.	3.4 x 5.2 x 8.2 in.
> Weight	29 lb.	30 lb.	47.5 lb.	3.6 lb.

How is a **WHOLE HOUSE** transfer switch with **DEMAND CONTROL** wired?

ATS200 connection to HVAC

This ATS includes two banks of four relays (15 Amp) for you to easily wire in your low voltage controlled HVAC by simply breaking the thermostat control line as shown below.

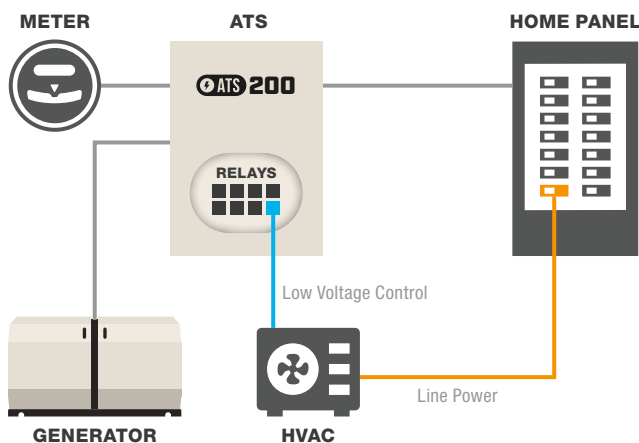

ATS200 connection to ELECTRIC RANGE with LCM

High demand appliances can be managed using a relay (up to 8) connected to a LOAD CONTROL MODULE wired between the circuit breaker in the distribution panel and the appliance.

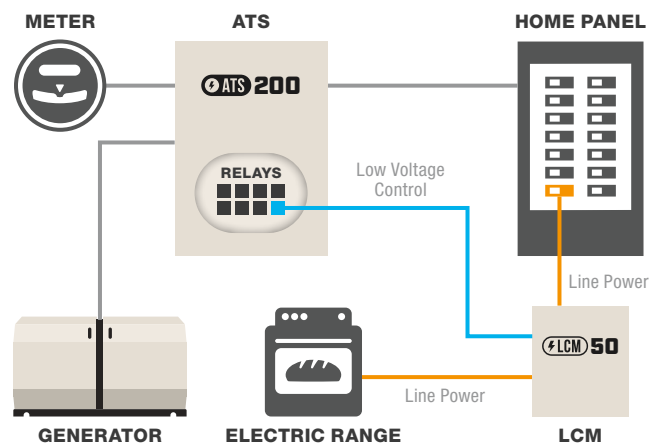

Locate a certified Champion Home Standby Dealer and Installer by visiting:
www.championpowerequipment.com or emailing hsb@cpeauto.com

Champion Power Equipment, Inc.
 12039 Smith Ave. – Santa Fe Springs, CA 90670 – USA
hsb@cpeauto.com – 1-877-338-0999