

CHAMPION

POWER EQUIPMENT

TM-MC

OWNER'S MANUAL & OPERATING INSTRUCTIONS



3 IN. (7.6 cm) HOSE KIT



MODEL NUMBER

100198

SAVE THESE INSTRUCTIONS
Important Safety Instructions
are included in this manual.

REV 100198-20200811

12039 Smith Ave.
Santa Fe Springs CA 90670
USA / 1-877-338-0999
www.championpowerequipment.com

Have questions or need assistance?

Do not return this product to the store!

WE ARE HERE TO HELP!

Visit our website:

www.championpowerequipment.com

for more info:

- Product Info & Updates
- Tech Bulletins
- Frequently Asked Questions
- Product Registration

– or –

Call our Customer Care Team Toll-Free at:

1-877-338-0999

WARNING: Cancer and Reproductive Harm – www.P65Warnings.ca.gov

*We are always working to improve our products. Therefore, the enclosed product may differ slightly from the image on the cover.

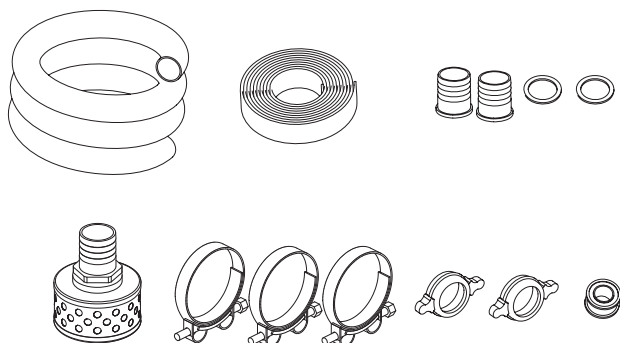

3 IN. (7.6 cm) HOSE KIT

TABLE OF CONTENTS

Introduction	1	Warranty Exclusions	6
Introduction	1	Normal Wear	6
Manual Conventions	2	Installation, Use and Maintenance	6
Safety Rules	2	Other Exclusions	6
Specifications	3	Limits of Implied Warranty and Consequential Damage	6
Parts Diagram	3	Contact Information	6
Parts List	3	Address	6
Operation	4	Customer Service	6
Pump Location	4	Technical Service	6
Connecting a Hose Kit	4		
Priming Pump	5		
Warranty	6		
Warranty Qualifications	6		
Repair/Replacement Warranty	6		
Do Not Return The Unit To The Place Of Purchase	6		

INTRODUCTION

Introduction

Congratulations on your purchase of a Champion Power Equipment product. Champion Power Equipment and Champion Engine Technology designs, builds, and supports all of our products to strict specifications and guidelines. With proper product knowledge, safe use, and regular maintenance, this product should bring years of satisfying service.

Every effort has been made to ensure the accuracy and completeness of the information in this manual, and we reserve the right to change, alter and/or improve the product and this document at any time without prior notice.

Since CPE/CET highly value how our products are designed, manufactured, operated and are serviced, and also highly value your safety and the safety of others, we would like you to take the time to review this product manual and other product materials thoroughly and be fully aware and knowledgeable of the assembly, operation, dangers and maintenance of the product before use. Fully familiarize yourself, and make sure others who plan on operating the product fully familiarize themselves too, with the proper safety and operation procedures before each use. Please always exercise common sense and always err on the side of caution when operating the product to ensure no accidents, property damage, or injury occurs. We want you to continue to use and be satisfied with your CPE/CET product for years to come.

Record the model and serial numbers as well as date and place of purchase for future reference. Have this information available when ordering parts and when making technical or warranty inquiries.

Champion Power Equipment Support
1-877-338-0999
Model Number
100198
Date of Purchase
Purchase Location

This manual uses the following symbols to help differentiate between different kinds of information. The safety symbol is used with a key word to alert you to potential hazards in operating and owning power equipment.

Follow all safety messages to avoid or reduce the risk of serious injury or death.

DANGER

DANGER indicates an imminently hazardous situation which, if not avoided, **will** result in death or serious injury.

WARNING

WARNING indicates a potentially hazardous situation which, if not avoided, **could** result in death or serious injury.

CAUTION

CAUTION indicates a potentially hazardous situation which, if not avoided, **may** result in minor or moderate injury.

CAUTION

CAUTION used without the safety alert symbol indicates a potentially hazardous situation which, if not avoided, **may** result in property damage.

NOTE

If you have questions regarding your pump, we can help. Please call our help line at **1-877-338-0999**

SAFETY RULES

WARNING

Read this manual thoroughly before operating your pump. Failure to follow instructions could result in serious injury or death.

DANGER

DO NOT pump gasoline and fuel oil mixtures, detergents, acids, chemicals, beverages, pesticides, fertilizers or any other flammable liquid or corrosive.

Pumping volatile liquids may result in an explosion or fire. These liquids will corrode the pump and void your warranty.

WARNING

Water pumped through this unit shall not be used as drinking water.

CAUTION

Exceeding the pump's specification for maximum head can damage the pump and/or hose kits connected to it.

DO NOT modify the pump in any way. DO NOT attempt to exceed the rated flow. Attempting to increase the rated flow may damage the unit and/or shorten its life.

DANGER

The pump develops powerful force.

DO NOT move the pump when it is in use. DO NOT use hoses or connectors that are worn, damaged or frayed. DO NOT allow children or unqualified persons to operate or service the water transfer pump. DO NOT open top plug or drain plug.

SPECIFICATIONS

Parts Diagram

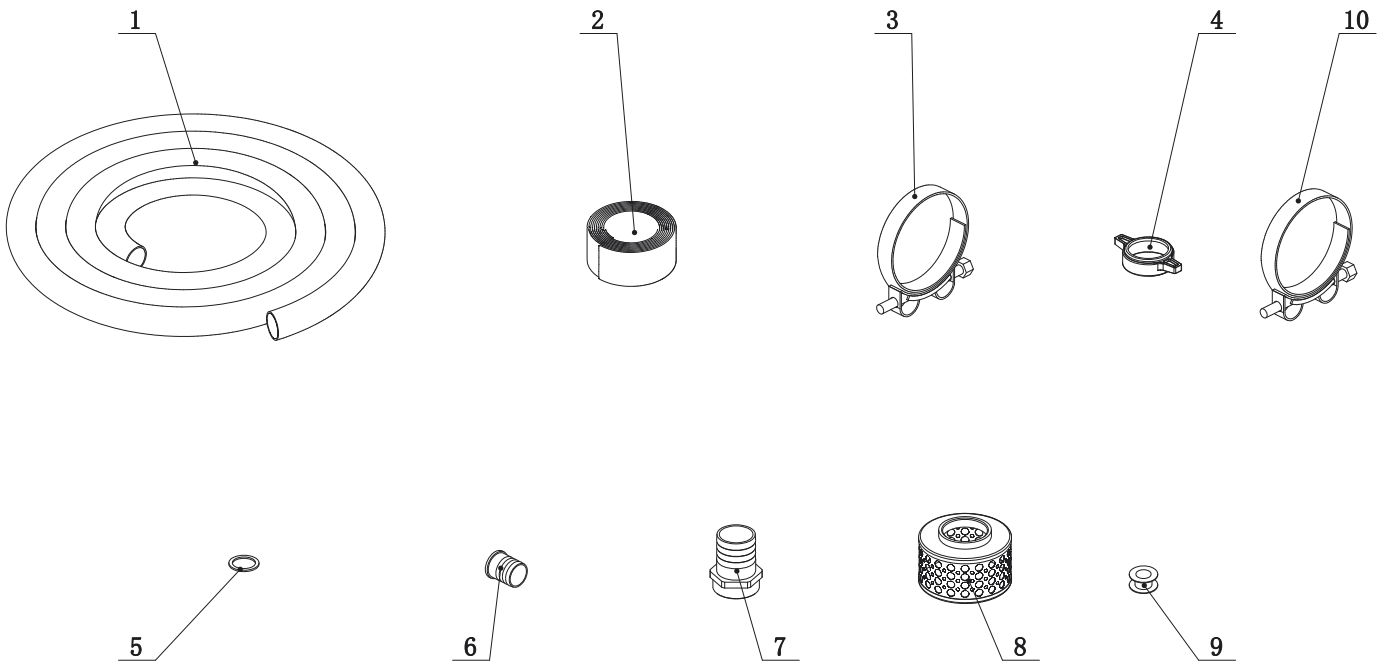

#	Part Number	Description	Qty
1	9.1800.007	Inlet Hose, 20 ft.	1
2	9.1800.008	Outlet Hose, 25 ft.	1
3	2.06.041	Clamp, 22 x 80-85 mm, Inlet	2
4	203.250005.03	Hose Adapter	2
5	203.250002.01	Seal Ring	2

#	Part Number	Description	Qty
6	203.250001.01	Hose Fitting	2
7	221.250004.01	Strainer Adapter	1
8	203.250003.03	Strainer	1
9	9.1900.001	Teflon Tape	1
10	2.06.045	Clamp, 22 x 74-79 mm, Outlet	1

Pump Location

Place the pump in a well ventilated area. DO NOT place the pump near vents or intakes where exhaust fumes could be drawn into occupied or confined spaces. Carefully consider wind and air currents when positioning the pump.

This pump must have at least 5 ft. (1.5 m) of clearance from combustible material. Leave at least 3 ft. (91.4 cm) of clearance on all sides of the pump to allow for adequate cooling, maintenance and servicing. Place the pump on a level surface free from any obstructions or potential hazards. The pump should be placed close to the water level to ensure maximum pump performance. Pump output will be affected by the type, length, and size of the suction and discharge hoses.

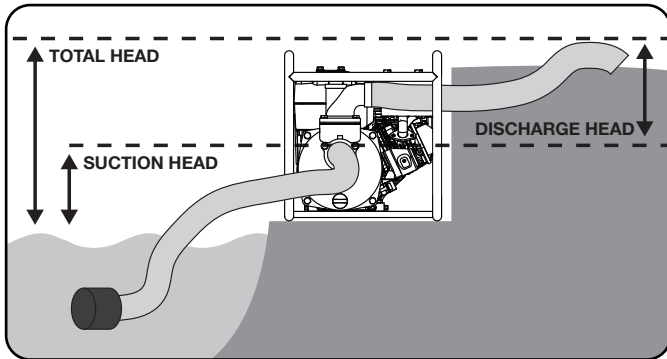

The pumping height, also known as the total head, is the distance from the water level to the point of discharge. As this distance increases, pump output decreases. The discharge capacity is greater than the suction capacity. Therefore, it is important that the suction head is less than the discharge head.

The time required to draw water from the source to the pump (self-priming time) can be decreased by minimizing the suction head.

Connecting a Hose Kit

NOTE

Both the intake and discharge ports are 3 in. (7.6 cm) NPT. Please insure the connectors to the suction and discharge hose are 3 in. (7.6 cm) NPT threaded.

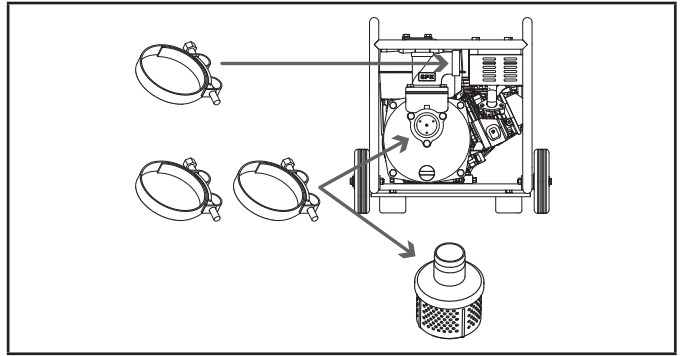

2 qty.	80-85 mm ID clamp	For green suction hose connection to pump inlet port (center of pump and intake screen).
1 qty.	74-79 mm ID clamp	For blue discharge hose.

Use 74-79 mm ID clamp for blue discharge hose.

1. Attach and thread the connector to the threaded fitting (top of pump). Install hose clamp over the blue hose.

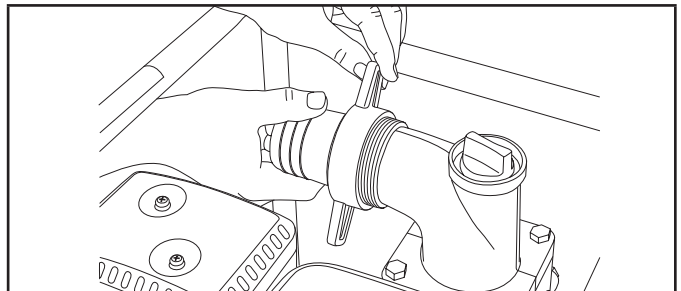

2. Slide the blue discharge hose over the discharge fitting (top of pump) and secure with the hose clamp (74-79 mm ID) with wrench.

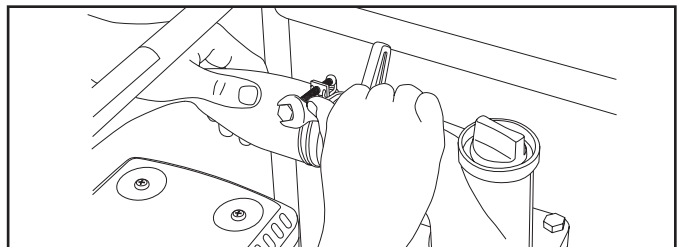

Use 80-85 mm ID clamp for screen.

1. Install hose clamp over the green suction hose. Slide the green suction hose over the screen and secure the hose clamp (80-85 mm ID) with wrench.

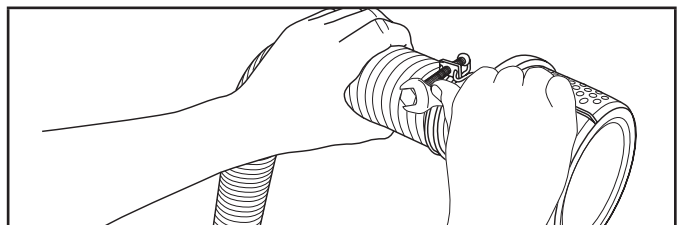

OPERATION

Connecting a Hose Kit Cont'd

Use 80-85 mm ID Clamp for pump suction hose.

1. Slide clamp (80-85 mm ID) over the green suction hose approximately 4 in. (10.1 cm) from end.

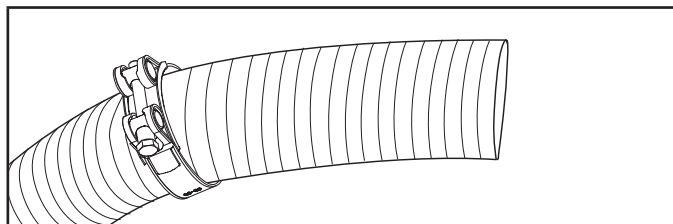

2. Insert the threaded or quick coupler in the green rigid suction hose until properly seated. If tight fit, feel free to use a small amount of dish soap on the inner diameter of the hose.

NOTE

When sliding hose over barbed fittings, apply thin coating of liquid dish soap on inside of hose to allow easier assembly

*We are always working to improve our products. Therefore, the enclosed product may differ slightly from the illustration.

Priming the Pump

! WARNING

DO NOT run the pump dry.

Running the pump dry can destroy the pump seals and will void the warranty. If the pump was running while dry, stop the engine and allow it to cool thoroughly before filling the chamber with water.

Located on the outlet flange is the priming plug. Remove the priming plug and fill pump body to the very top of outlet flange with water. Reinstall the priming plug. As the engine starts up, this will start the draw of liquid into the pump. Located within the pump assembly is the one-way valve. As you prime the pump housing this one-way flap valve shuts off the opening to the suction hose. The priming process is only required when the pump housing is not full of water.

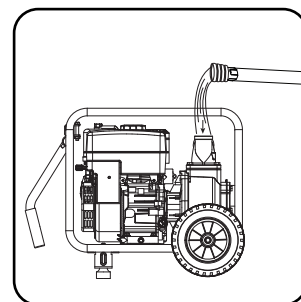
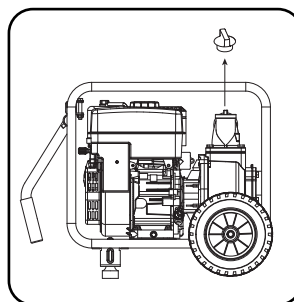

NOTE

Ensure the priming plug is secure before pump operation, if not secure the priming plug could be ejected and water or other liquids could be pumped through the top of the outlet flange.

WARRANTY*

CHAMPION POWER EQUIPMENT
1 YEAR LIMITED WARRANTY

Warranty Qualifications

To register your product for warranty and FREE lifetime call center technical support please visit:

<https://www.championpowerequipment.com/register>

To complete registration you will need to include a copy of the purchase receipt as proof of original purchase. Proof of purchase is required for warranty service. Please register within ten (10) days from date of purchase.

Repair/Replacement Warranty

CPE warrants to the original purchaser that the mechanical and electrical components will be free of defects in material and workmanship for a period of one year (parts and labor) from the original date of purchase and 90 days (parts and labor) for commercial and industrial use. Transportation charges on product submitted for repair or replacement under this warranty are the sole responsibility of the purchaser. This warranty only applies to the original purchaser and is not transferable.

Do Not Return The Unit To The Place Of Purchase

Contact CPE's Technical Service and CPE will troubleshoot any issue via phone or e-mail. If the problem is not corrected by this method, CPE will, at its option, authorize evaluation, repair or replacement of the defective part or component at a CPE Service Center. CPE will provide you with a case number for warranty service. Please keep it for future reference. Repairs or replacements without prior authorization, or at an unauthorized repair facility, will not be covered by this warranty.

Warranty Exclusions

This warranty does not cover the following repairs and equipment:

Normal Wear

Products with mechanical and electrical components need periodic parts and service to perform well. This warranty does not cover repair when normal use has exhausted the life of a part or the equipment as a whole.

Installation, Use and Maintenance

This warranty will not apply to parts and/or labor if the product is deemed to have been misused, neglected, involved in an accident, abused, loaded beyond the product's limits, modified, installed improperly or connected incorrectly to any electrical component. Normal maintenance is not covered by this warranty and is not required to be performed at a facility or by a person authorized by CPE.

Other Exclusions

This warranty excludes:

- Cosmetic defects such as paint, decals, etc.
- Wear items such as filter elements, o-rings, etc.
- Accessory parts such as starting batteries, and storage covers.
- Failures due to acts of God and other force majeure events beyond the manufacturer's control.
- Problems caused by parts that are not original Champion Power Equipment parts.

Limits of Implied Warranty and Consequential Damage

Champion Power Equipment disclaims any obligation to cover any loss of time, use of this product, freight, or any incidental or consequential claim by anyone from using this product. THIS WARRANTY IS IN LIEU OF ALL OTHER WARRANTIES, EXPRESS OR IMPLIED, INCLUDING WARRANTIES OF MERCHANTABILITY OR FITNESS FOR A PARTICULAR PURPOSE.

A unit provided as an exchange will be subject to the warranty of the original unit. The length of the warranty governing the exchanged unit will remain calculated by reference to the purchase date of the original unit.

This warranty gives you certain legal rights which may change from state to state or province to province. Your state or province may also have other rights you may be entitled to that are not listed within this warranty.

Contact Information

Address

Champion Power Equipment, Inc.
12039 Smith Ave.
Santa Fe Springs, CA 90670 USA
www.championpowerequipment.com

Customer Service

Toll Free: 1-877-338-0999
info@championpowerequipment.com
Fax no.: 1-562-236-9429

Technical Service

Toll Free: 1-877-338-0999
tech@championpowerequipment.com
24/7 Tech Support: 1-562-204-1188