

30
kW



YOU.POWERED.

LIQUID COOLED Standby Generators



SPECIFICATIONS

OVERVIEW			
Brand	Briggs & Stratton®		Fortress™
Model Number	076191	076193	076880
Rated Countries	US / Canada		
Rated AC Voltage (Volts)	120/208	120/240	120/240
Frequency (Hz)	60		
Generator Breaker (Amps)	110	90	125
Operating Ambient Temperature (°C / °F)	-28 - 40 / -20 - 104		
Running Amperage (Amps)	104	90	125
Running Watts¹ (LP / NG) (kW / kVA)	30 / 37		30 / 30
Phase	3		1
Engine			
Engine Brand/Manufacturer	Briggs & Stratton		
Model Type	1.6L, 4-cycle		
Aspiration	Naturally Aspirated		
Speed (RPM)	3600		
Displacement (L / ci)	1.6 / 97		
Compression Ratio	9.5:1		
Rated Horsepower (gross hp)	49		
Governor Type	Electronic		
Bore & Stroke (mm/in)	81 x 77 / 3.19 x 3.03		
Number of Cylinders	4		
Cylinder Arrangement	Inline 4		
Start Type	Automatic		
Frequency Regulation Steady State, No Load to Full Load (%)	+/- 0.5		

30

kW

LIQUID COOLED Standby Generators



SPECIFICATIONS

076191

076193

076880

Engine	
Frequency Regulation No Load to Full Load	Isochronous
Air Filter Type	Dry
Low Oil Pressure Sensor	Yes
Low Coolant Sensor	Yes
Engine Block Heater	Yes
Engine - Output Deratings	
Rated Temperature (°C / °F)	25 / 77
Rated Altitude (Above Sea Level) (m / ft)	366 / 1200
Temperature Derate	1.5% for every 5.6°C (10°F) above rated temp
Altitude Derate	2.5% for every 305m (1000ft) above rated altitude
Sound Rating ²	
No Load dB(A)	66
Air Induction System	
Combustion Air (m ³ /min / cfm)	2.2 / 79
Lubrication System	
Type	Full Pressure
Oil Capacity (L / qt)	3.5 / 3.7
Oil Filter (Quantity / Type)	1 / Cartridge
Cooling System	
Cooling System Type	Radiator, Closed-loop
Coolant Capacity (Engine Only) (L / qt)	9.3 / 2.5
Heat Rejected to Cooling Water at Rated Load (kcal/sec / BTU/min)	5.7 / 1366
Water Pump Type	Centrifugal
Electrical System	
Ignition System	Electronic
Battery Quantity	1
Battery Voltage (VDC)	12
Battery CCA (Amps)	800
Starter Motor Voltage (VDC)	12

30

kW

LIQUID COOLED Standby Generators



SPECIFICATIONS

076191

076193

076880

Battery Charging Alternator	
Ground (Negative / Positive)	Negative
Nominal Voltage (VDC)	12
Maximum Amperage (Amps)	90
Exhaust System	
Exhaust Manifold Type	Dry
Exhaust Flow at Rated Load (m ³ /min / cfm)	7.7 / 271
Exhaust Temperature at Rated Load (°C / °F)	693 / 1280
Maximum Allowable Back Pressure (kPa / in Hg)	11.9 / 3.5
Fuel System	
Fuel Type	NG / LPV
Fuel Supply Line Inlet	1" NPT
Recommended Fuel, Lower Heating Value Minimum (MJ/m ³ / BTU/ft ³)	NG: 34.3 / 904 LPV: 87.1 / 2338
Fuel Supply Pressure (mbar / in H ₂ O)	12-28 / 5-11
Fuel Consumption ³	
No Load, NG (BTU / hr)	146,000
No Load, NG (ft ³ / hr)	146
No Load, NG (m ³ / hr)	4.2
Half Load, NG (BTU / hr)	293,000
Half Load, NG (ft ³ / hr)	293
Half Load, NG (m ³ / hr)	8.3
Full Load, NG (BTU / hr)	444,000
Full Load, NG (ft ³ / hr)	444
Full Load, NG (m ³ / hr)	12.6
No Load, LP (BTU / hr)	154,000
No Load, LP (ft ³ / hr)	62
No Load, LP (m ³ / hr)	1.8
Half Load, LP (BTU / hr)	328,000
Half Load, LP (ft ³ / hr)	132
Half Load, LP (m ³ / hr)	3.8
Full Load, LP (BTU / hr)	483,000
Full Load, LP (ft ³ / hr)	194
Full Load, LP (m ³ / hr)	5.5

30

kW

LIQUID COOLED Standby Generators



SPECIFICATIONS

076191

076193

076880

Alternator Specifications		
Alternator Type	Self-Excited, 12-Lead	Self-Excited, 4-Lead
Alternator Manufacturer	Coliseum	
Alternator Model Number	30TBSPP2-2	30BSPP2-0
Frequency (Hz)	60	
Exciter Type - Primary Alternator	Self-Excited	
Insulation Rating (Class)	H	
Designed Temperature Rise (°C)	125	
Bearing (Quantity / Type)	1 / Sealed	
Coupling	Flexible Disk	
Amortisseur Windings	Full	
Number of Poles	2	
Voltage Regulator	Analog, 1-Phase Sensing	
Voltage Regulation, No Load to Full Load (%)	+/- 1.0	
One-step Load Acceptance	100% of Rating	
Total Harmonic Distortion (THD), No Load to Full Load (%)	< 5	
Controls/Instrumentation		
Controller Manufacturer	Briggs & Stratton	
Controller	Briggs & Stratton	
Charger	Integrated	
Starting	AMF	
Alternator Frequency	Yes	
Real Time Clock	Yes	
Engine Hour Counter	Yes	
Engine Runtime Scheduler	Yes	

30

kW

LIQUID COOLED Standby Generators



SPECIFICATIONS

076191

076193

076880

Other Features		
Battery Rack and Cables	Yes	
Electronic, Isochronous Governor	Yes	
Gas Fuel System	Yes	
Integral Vibration Isolation	Yes	
Oil Drain Extension	Yes	
Operation and Installation Manual(s)	Yes	
Steel Sound Enclosure	Yes	
Accessories		
Local Emergency Stop Switch	6491-01	
Cold Weather Kit	6270-00	
Battery Warmer	6342-00	
Battery Cable Lockout	6335-00	
Engine Communication Cable	6275-00	
Controller Communication Cable, USB-A to USB-B	6428-00	
Maintenance Kit, Oil Change	6280-00	
Maintenance Kit, 1,000 hr	6268-00	
Limited Warranty ⁴		
Warranty: Generator, Domestic (Parts / Labor / Travel) (Years)	5	6
Warranty: Generator, International (Parts / Labor / Travel) (Years/Hours)	3 / 1000	N/A
Warranty: Engine, Domestic (Parts / Labor / Travel) (Years)	5	6
Warranty: Enclosure, Surface Rust and Corrosion (Parts / Labor / Travel) (Years)	1	
Warranty: Enclosure, Rust Through (Parts / Labor / Travel) (Years)	2	

30

kW

LIQUID COOLED Standby Generators



SPECIFICATIONS

076191

076193

076880

Certifications	
UL	Yes
cUL	Yes
Weights & Dimensions	
Assembled Dimensions (Length x Width x Height) (in / mm)	71 x 32.3 x 37 / 1803 x 820 x 940
Assembled Weight (lbs / kg)	1000 / 454
Packaged Dimensions (Length x Width x Height) (in / mm)	75.8 x 35.9 x 43.7 / 1925 x 912 x 1110
Packaged Weight (lbs / kg)	1086 / 493

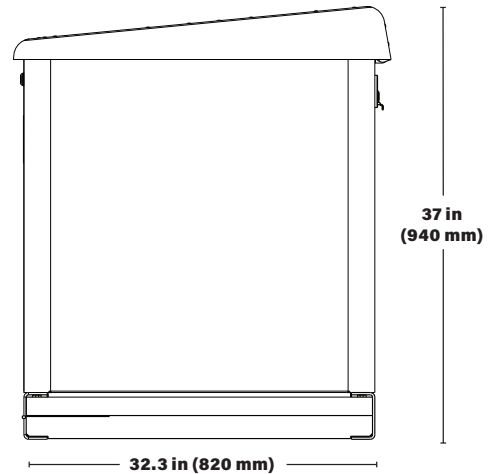
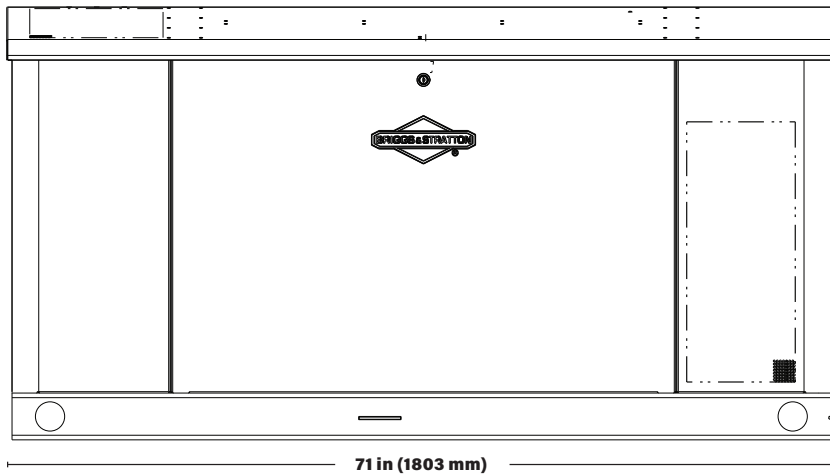

¹ This generator is listed in accordance with UL (Underwriters Laboratories) 2200 (stationary engine generator assemblies) and CSA (Canadian Standards Association) standard C22.2 No. 100-14 (motor and generators).

² Per ISO 3744. Sound level measurement at other locations around generator may differ depending on installation, based on lowest microphone at 7m. Normal operation based on average household usage.

³ Fuel consumption rates are estimated based on normal operating conditions. Generator operation may be greatly affected by elevation and the cycling operation of multiple electrical appliances — fuel flow rates may vary depending on these factors.

⁴ See operator's manual or BRIGGSandSTRATTON.com for complete warranty details.

Briggs & Stratton has a policy of continuous product improvement and reserves the right to modify its specifications at any time and without prior notice. This standby generator is not for Prime Power applications.

Please visit BRIGGSandSTRATTON.com for the latest information.

BS1373 - 4/22

BRIGGS & STRATTON
POST OFFICE BOX 702
MILWAUKEE, WI 53201 USA

Copyright © 2022 Briggs & Stratton. All rights reserved.