

**DIESEL GENERATOR
MMG130DI4 • MMG175DI4 • MMG205DI4**

With **Power Zone™** Controller

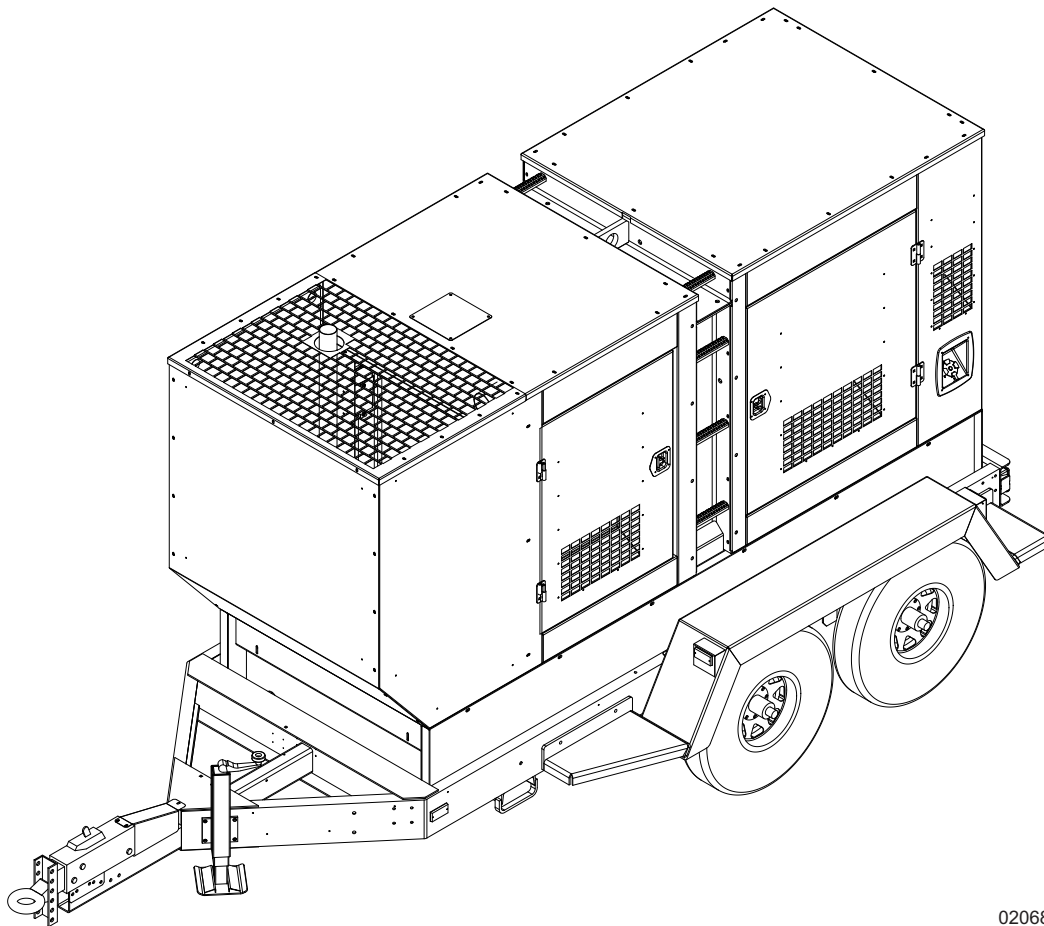

02068

OPERATING MANUAL

Parts manuals available online at www.generacmobile.com

⚠ WARNING

CALIFORNIA PROPOSITION 65 WARNING: Diesel engine exhaust and some of its constituents are known to the state of California to cause cancer, birth defects, and other reproductive harm. (000004)

⚠ WARNING

CALIFORNIA PROPOSITION 65 WARNING: This product contains or emits chemicals known to the state of California to cause cancer, birth defects, and other reproductive harm. (000005)

⚠ WARNING

ENVIRONMENTAL HAZARD: Always recycle batteries at an official recycling center in accordance with all local laws and regulations. Failure to do so could result in environmental damage, death or serious injury. (000228)

Introduction

This manual provides information and procedures to safely operate and maintain the Generac Mobile Products unit. For your own safety and protection from physical injury, carefully read, understand, and observe the safety instructions described in this manual. Keep a copy of this manual with the unit at all times. Additional copies are available from Generac Mobile Products, or can be found at www.generacmobile.com. *The information contained in this manual was based on machines in production at the time of publication. Generac Mobile Products reserves the right to change any portion of this information without notice.*

Read all of the manuals included with the unit. Each manual details specific information regarding items such as setup, use and service requirements. An engine operator's manual provides detailed operation and maintenance procedures for the engine. Additional copies of the engine operator's manual are available from the engine manufacturer.

DO NOT MODIFY or use this equipment for any application other than for which it was designed.

Only a trained and licensed electrician should perform wiring and connections to unit. Wiring must be in compliance with National Electrical Code (NEC), state and local regulations, as well as Occupational Safety and Health Administration (OSHA) guidelines.

GENERAC MOBILE PRODUCTS LLC

215 Power Drive • Berlin, WI 54923

U.S.A.

Phone: 920-361-4442

FAX: 920-361-4416

Toll Free: 1-800-926-9768

www.generacmobile.com

For technical or parts QUESTIONS, please contact the Generac Mobile Products Customer Support or Technical Support team at 1-800-926-9768. Please have your serial number available.

To ORDER SERVICE PARTS, please contact the dealer from which you purchased the unit, or call Generac Mobile Products to locate a dealer in your area.

Engine Make: _____

Engine Serial Number: _____

Engine Model Number: _____

Generator Make: _____

Generator Model Number: _____

Generator Serial Number: _____

Unit Model Number: _____

Unit Serial Number: _____

This Page Intentionally Left Blank

Table of Contents

Introduction	iii
Section 1 - Safety	
Safety Notes	1
Operating Safety.....	1
Engine Safety	2
service Safety	2
Towing Safety.....	3
Reporting Trailer Safety Defects	3
Safety Symbol Summary	4
Section 2 - General Information	
Specifications	5
Unit Dimensions	8
Unit Serial Number Locations	9
Component Locations.....	10
Control Panel.....	11
Control panel - with cam lock option.....	12
Power Zone™ Controller	13
Controller Features and Functions	13
Operator Screens	13
Alarm Mute	13
Auto/Manual Mode	14
Navigation Buttons	14
Control Power Switch	14
Engine Start.....	14
Engine Stop/Reset.....	14
The Liquid Crystal Display (LCD)	14
Operator Screens	14
Home Screen.....	14
Engine Screen.....	15
Generator Screen	16
Voltage Adjust Screen	16
Maintenance Screens	17
Generator Summary	17
Engine Tab	17
Generator Tab	18
Alarms Tab	18
Input/Output Tab.....	20
Schedule Tab	20
Status Tab	21
Generator Monitoring.....	21
Engine Monitoring.....	21
Diesel Exhaust Filter Monitoring.....	21
Power Zone™ Controller Information Displays, Functions, And Reset.....	22
Belt Tensioners.....	22
Section 3 - Operation	
Prestart Checklist	23
Manually Starting the Unit	23
Auto (Remote) Starting of the Unit	25
Derating for Altitude	25
Generator Output Connections.....	25
Generator Cam Lock Connection(s) Option	26
Fine Voltage Adjustment	28
Voltage Selector Switch.....	28

Voltage Regulator	30
Customer Convenience Receptacles	30
Main Circuit Breaker	31
Exhaust Filter Cleaning Operations	31
Transfer Switch.....	31
Auto Exercise Timer	33
Accessing the Configuration Menu	33
Set the Controller Clock.....	33
Set the Schedule	33
Set the Unit To Auto Mode	34
Shutting Down the Unit.....	34
Emergency Stop Switch	34
Towing The Unit	35
Lifting The Unit	35
Section 4 - Maintenance	
Emissions Information	37
Daily Walk Around Inspection.....	37
General Maintenance	37
Basic Maintenance Schedule - John Deere Engine	38
Engine Break-in Requirements.....	39
Resetting The Maintenance Alarms	39
Exhaust Filter Service Requirements (for pz units with dpf Only)	40
Checking Generator Drive Plate Torque	40
Jack Maintenance.....	40
Side-Wind Models	40
Top-Wind Models	41
Trailer Wheel Bearings	41
Section 5 - Troubleshooting	
General Troubleshooting	43
Section 6 - Wiring Diagrams	
AC Wiring - 3 Position Voltage Selector Switch - MMG130DI4	45
AC Wiring - 3 Position Voltage Selector Switch - MMG175DI4	46
AC Wiring - 3 Position voltage selector switch - MMG205DI4.....	47
AC Wiring - 4 Position Voltage Selector Switch Option - MMG130DI4, MMG175DI4	48
AC Wiring - 4 Position Voltage Selector Switch Option - MMG205DI4	49
AC Wiring Options	50
DC Wiring	51
DC Wiring Options.....	52
Wiring Block Diagram - Dedicated 12 Lead Generators Option	53
Trailer Lights Wiring.....	54
Wiring Harness - Electric Brake Option	55
Section 7 - Options & Accessories	
Generator Cam Lock Connections Option.....	57
Viscous Fan Clutch Option	58

Section 1 - Safety

SAFETY NOTES



This is the safety alert symbol. It is used to alert you to potential personal injury hazards. Obey all safety messages that follow this symbol to avoid possible injury or death.

This manual contains DANGERS, WARNINGS, CAUTIONS, NOTICES and NOTES which must be followed to prevent the possibility of improper service, damage to the equipment, personal injury or death. The following formatting options will apply when calling the readers attention to the DANGERS, WARNINGS, CAUTIONS, NOTICES and NOTES.

▲ DANGER

INDICATES A HAZARDOUS SITUATION WHICH, IF NOT AVOIDED, WILL RESULT IN DEATH OR SERIOUS INJURY.

▲ WARNING

Indicates a hazardous situation which, if not avoided, could result in death or serious injury.

▲ CAUTION

Indicates a hazardous situation which, if not avoided, could result in minor or moderate injury.

NOTICE

Indicates a hazardous situation which, if not avoided, could result in property or equipment damage.

Note: Notes contain additional information important to a procedure and will be found within the regular text body of this manual.

OPERATING SAFETY



Before using the unit, be sure you read and understand all of the instructions. This equipment was designed for specific applications; **DO NOT** modify or use this equipment for any application other than which it was designed for. Equipment operated improperly or by untrained personnel can be dangerous. Read the operating instructions and familiarize yourself with the location and proper use of all instruments and controls. Inexperienced operators should receive instruction from someone familiar with the equipment before being allowed to operate or set up the unit. The following points should be practiced at all times:

- The area immediately surrounding the unit should be dry, clean, and free of debris.
- Position and operate the unit on a firm, level surface.
- **DO NOT** start a unit in need of repair.
- If the unit is equipped with a frame grounding stud, follow any local, state, and National Electrical Code (NEC) guidelines when connecting.
- **DO NOT** operate the unit on a combustible surface.
- **DO NOT** operate a unit while tired, distracted, or under the influence of drugs or alcohol.
- Keep all body parts, clothing and other loose items away from moving parts.
- **DO NOT** fill fuel tank near an open flame, while smoking, or while engine is running. **DO NOT** fill tank in an enclosed area with poor ventilation.
- **DO NOT** operate with the fuel tank cap loose or missing.
- Shut the engine down if any of the following conditions exist during operation:

1. Noticeable change in engine speed.
2. Loss of electrical output.
3. Equipment connected to the unit overheats.
4. Sparking occurs.
5. Engine misfires or there is excessive engine/generator vibration.
6. Protective covers are loose or missing.
7. If the ambient air temperature is above 120°F (49°C).

ENGINE SAFETY



Internal combustion engines present special hazards during operation and fueling. Failure to follow the safety guidelines described below could result in severe injury or death. Read and follow all safety warnings described in the engine operator's manual. A copy of this manual was supplied with the unit when it was shipped from the factory.

- **DO NOT** run engine indoors or in an area with poor ventilation unless exhaust hoses are used. Engine exhaust contains carbon monoxide, a deadly, odorless and colorless gas which, if inhaled, can cause nausea, fainting or death. Make sure engine exhaust cannot seep into closed rooms or ventilation equipment.
- **DO NOT** touch or lean against hot exhaust pipes or engine components.
- **DO NOT** clean air filter with gasoline or other types of low flash point solvents.
- **DO NOT** operate the unit without a functional exhaust system.
- Prolonged exposure to sound levels in excess of 85 dB(A) can cause permanent hearing loss. Wear hearing protection when working around a running engine.
- Batteries contain sulfuric acid which can cause severe injury or death. Sulfuric acid can cause eye damage, burn flesh or eat holes in clothing. Protective eye wear and clothing are necessary when working on or around the battery. Always disconnect the negative (-) battery cable from the corresponding terminal before performing any service on the engine or other components.
- **DO NOT** open the radiator cap or oil drain plug while the engine is running or before the engine has cooled down. Pressurized coolant and hot engine oil can cause severe burns. Allow the unit to cool completely before attempting any service work.
- Keep area around exhaust pipes and air ducts free of debris to reduce the chance of an accidental fire.

SERVICE SAFETY



All service work must be performed by qualified personnel who are familiar with the equipment. Only a qualified electrician should troubleshoot or repair electrical problems occurring in this equipment. Follow the safety guidelines described below to prevent hazardous situations which could result in severe injury or death.

- **NEVER** wash the unit with high pressure hoses, power washers, or steam cleaners. Water may collect in the unit, causing damage to electrical parts.
- **ALWAYS** use extreme caution when servicing this unit in damp conditions. Do not service the unit if your skin or clothing is wet. Do not allow water to collect around the base of the unit.
- Replace all missing and hard to read decals. Decals provide important operating instructions and warn of dangers and hazards.
- Before servicing the unit, verify the Control Power switch and circuit breakers are in the OFF (O) position, and the negative (-) terminal on the battery is disconnected. **DO NOT** perform even routine service (oil/filter changes, cleaning, etc.) unless all electrical components are shut down.

- **DO NOT** start the unit under load. The circuit breakers must be in the OFF (O) position when starting the unit in Manual mode. The circuit breakers can be in the ON (I) position only when started in the Auto mode. A transfer switch must be used in the Auto mode to deflect the load upon startup.

TOWING SAFETY



Towing a trailer requires care. Both the trailer and vehicle must be in good condition and securely fastened to each other to reduce the possibility of an accident. Some states require that large trailers be registered and licensed. Contact your local Department of Transportation office to check on license requirements for your particular unit.

- Verify the hitch and coupling on the towing vehicle are rated equal to, or greater than, the trailer's Gross Vehicle Weight Rating (GVWR).
- Check trailer tires for wear and proper inflation.
- **DO NOT** tow trailer using defective parts. Inspect the hitch and coupling for wear or damage.
- Verify the trailer hitch and the coupling are compatible. Make sure the coupling is securely fastened to the vehicle.
- Verify directional and brake lights on the trailer are connected and working properly.
- Verify wheel lug nuts are present and tightened to the specified torque.
- Maximum recommended speed for highway towing is 45 mph (72 km/h). Recommended off-road towing speed is 10 mph (16 km/h).
- When towing, maintain extra space between vehicles and avoid soft shoulders, curbs and sudden lane changes. Practice turning, stopping and backing up in an area away from heavy traffic prior to transporting the unit.
- Wipe the coupler clean and apply fresh grease each time the trailer is towed to eliminate squeaking.
- Connect safety chains in a crossing pattern under the tongue and **ATTACH THE BREAKAWAY CABLE TO THE REAR BUMPER OF THE TOWING VEHICLE**. Do not attach the cable to the trailer hitch.
- Before towing the trailer, verify that the weight of the trailer is equal across all tires. On trailers with adjustable height hitches, adjust the angle of the trailer tongue to keep the trailer as level as possible. On units equipped with a tandem axle trailer, a large angle between the trailer and tow vehicle will cause more weight to be carried by one axle, which could cause premature wear on the tires and axles and cause potentially unsafe operating conditions.
- The trailer is equipped with hydraulic or electric surge brakes. Verify proper operation of the brakes by braking the vehicle at a slow speed before entering traffic. Both the trailer and the vehicle should brake smoothly. If the trailer seems to be pushing, verify the level in the brake fluid reservoir, if equipped.

REPORTING TRAILER SAFETY DEFECTS

If you believe your trailer has a defect which could cause a crash or could cause injury or death, you should immediately inform the National Highway Traffic Safety Administration (NHTSA) in addition to notifying Generac Mobile Products LLC.

If NHTSA receives similar complaints, it may open an investigation; and if it finds that a safety defect exists in a group of vehicles, it may order a recall and remedy campaign. However, NHTSA cannot become involved in an individual problem between you, your dealer, or Generac Mobile Products LLC.

To contact NHTSA, you may either call the Auto Safety Hotline toll-free at 1-888-327-4236 (TTY:1-800-424-9153), go to <http://www.safercar.gov>; or write to:

Administrator
NHTSA
1200 New Jersey Avenue S.E.
Washington, DC 20590

You can also obtain other information about motor vehicle safety from <http://www.safercar.gov>.

SAFETY SYMBOL SUMMARY

The safety and operating decals affixed to the unit provide important instructions and warn of dangers and hazards. Replace any missing or hard-to-read decals and use care when washing or cleaning the unit. Decal placement and part numbers can be found in the online parts manual at www.generacmobile.com. Below is a summary of the intended meanings for the symbols used on the decals.

	Safety alert symbol; used to alert you to potential personal injury hazards.		Asphyxiation hazard; operate in well ventilated area.
	Hot surface(s) nearby.		Dangerous voltage may be present.
	Belt/entanglement hazard; keep body parts clear of this area.		Anchor/tie down point.
	Fan hazard; keep body parts clear of this area.		Isolate generator to prevent electrocution hazard.
	Never change switch position while engine is running.		Use clean diesel fuel only.
	Stop engine before making connections.		Remove negative battery cable before performing any service on unit.
	Stop engine before fueling.		Read and understand the supplied operator's manual before operating unit.
	Hearing protection required while operating unit with doors open.		Unit electrical ground.
	Lift here only.		Fire/explosion hazard; keep open flames away from unit.
	Engine running.		Burn/scald hazard; pressurized steam.
	Exhaust Filter Cleaning enabled.		Exhaust Filter Cleaning disabled.

00383

Figure 1-1. Decal Safety Symbol Summary

Section 2 - General Information

SPECIFICATIONS

GENERAC MODEL	MMG130DI4	MMG130DI4 Super Start
Engine		
Make/Brand.....	John Deere.....	John Deere
Model.....	PE4045HFG93.....	PE4045HFG93
EPA Tier.....	F4.....	F4
Horsepower - Prime hp (kW)	152 (113).....	152 (113)
Horsepower - Standby hp (kW)	166 (124).....	166 (124)
Operating Speed rpm	1800.....	1800
Displacement in³ (L)	275 (4.5).....	275 (4.5)
Cylinders - qty.....	4.....	4
Fuel Consumption - 100% Prime gph (Lph)	7.4 (28.0).....	7.4 (28.0)
Battery Type - Group Number.....	24.....	24
Battery Voltage (quantity per unit).....	12V (1).....	12V (1)
Battery Rating.....	1000 CCA.....	1000 CCA
Generator		
Make/Brand.....	Marathon Electric.....	Marathon Electric
Model.....	363PSL1607.....	431CSL6206
Type, Insulation.....	Brushless, H.....	Brushless, H
Generator Set (Engine/Generator)		
3Ø - Standby kW (kVA)	107 (134).....	110 (138)
Amps - 3Ø Standby 480V (208V) A	161 (372).....	166 (383)
3Ø - Prime kW (kVA)	98 (122).....	100 (125)
Amps - 3Ø Prime 480V (208V) A	147 (339).....	150 (347)
1Ø - Standby kW (kVA)	96 (96).....	108 (108)
Amps - 1Ø Standby - 240V A	400.....	450
1Ø - Prime kW (kVA)	90 (90).....	98 (98)
Amps - 1Ø Prime - 240V A	375.....	408
Frequency Hz	60.....	60
Power Factor.....	1 (1Ø), 0.8 (3Ø).....	1 (1Ø), 0.8 (3Ø)
Sound dB(A) 23 ft @ prime	68.....	68
Weights		
Dry Weight, Skid Mounted lbs (kg)	5444 (2469).....	5909 (2680)
Operating Weight, Skid Mounted lbs (kg)	7929 (3596).....	8394 (3807)
Dry Weight, Trailer Mounted* lbs (kg)	6840 (3102).....	7305 (3313)
Operating Weight, Trailer Mounted* lbs (kg)	9325 (4230).....	9790 (4441)
*Standard trailer only. Consult factory for custom trailer weights.		
Capacities		
Fuel Tank Volume gal (L)	342 (1295).....	342 (1295)
Usable Fuel Volume gal (L)	313 (1185).....	313 (1185)
Coolant (incl. engine) qt (L)	31.5 (29.8).....	31.5 (29.8)
Oil (incl. filter) qt (L)	33.0 (31.2).....	33.0 (31.2)
Maximum Run Time hrs	44.....	44
AC Distribution		
Circuit Breaker Size.....	450.....	450
Voltage Selection.....	3 position switch (lockable).....	3 position switch (lockable)
Voltage Regulation.....	+/- 0.5%.....	+/- 0.5%
Voltages Available 1Ø.....	120, 139, 208, 220, 240, 277.....	120, 139, 208, 220, 240, 277
Voltages Available 3Ø.....	208, 220, 440, 480.....	208, 220, 440, 480
Trailer		
Number of Axles.....	2.....	2
Capacity - Axle Rating lbs (kg)	6000 (2722).....	6000 (2722)
Tire Size in	16.....	16
Brakes.....	Surge.....	Surge
Hitch - Standard.....	3" ball.....	3" ball
Maximum Tire Pressure psi	75.....	75

General Information

GENERAC MODEL	MMG175DI4	MMG175DI4 Super Start
Engine		
Make/Brand.....	John Deere.....	John Deere
Model	PE6068HFG94	PE6068HFG94
EPA Tier	4i	4i
Horsepower - Prime hp (kW)	217 (162).....	217 (162)
Horsepower - Standby hp (kW)	241 (180).....	241 (180)
Operating Speed rpm	1800	1800
Displacement in³ (L)	415 (6.8).....	415 (6.8)
Cylinders - qty	6	6
Fuel Consumption - 100% Prime gph (Lph)	10.9 (41.3).....	10.9 (41.3)
Battery Type - Group Number.....	31	31
Battery Voltage (quantity per unit).....	12V (1)	12V (1)
Battery Rating	1000 CCA.....	1000 CCA
Generator		
Make/Brand.....	Marathon Electric	Marathon Electric
Model	431PSL6306	431PSL6306
Type, Insulation.....	Brushless, H.....	Brushless, H
Generator Set (Engine/Generator)		
3Ø - Standby kW (kVA)	153 (191).....	161 (201)
Amps - 3Ø Standby 480V (208V) A	230 (530).....	242 (558)
3Ø - Prime kW (kVA)	138 (172).....	145 (181)
Amps - 3Ø Prime 480V (208V) A	207 (477).....	218 (502)
1Ø - Standby kW (kVA)	125 (125).....	157 (157)
Amps - 1Ø Standby - 240V A	521	654
1Ø - Prime kW (kVA)	120 (120).....	143 (143)
Amps - 1Ø Prime - 240V A	500	596
Frequency Hz	60	60
Power Factor.....	1 (1Ø), 0.8 (3Ø).....	1 (1Ø), 0.8 (3Ø)
Sound dB(A) 23 ft @ prime	68	68
Weights		
Dry Weight, Skid Mounted lbs (kg)	6604 (2996).....	7069 (3206)
Operating Weight, Skid Mounted lbs (kg)	9032 (4097)	9497 (4307)
Dry Weight, Trailer Mounted* lbs (kg)	8000 (3629)	8465 (1646)
Operating Weight, Trailer Mounted* lbs (kg)	10428 (4730).....	10893 (4941)
*Standard trailer only. Consult factory for custom trailer weights.		
Capacities		
Fuel Tank Volume gal (L)	342 (1295).....	342 (1295)
Usable Fuel Volume gal (L)	313 (1185)	313 (1185)
Coolant (incl. engine) qt (L)	31.5 (29.8).....	31.5 (29.8)
Oil (incl. filter) qt (L)	33.0 (31.2).....	33.0 (31.2)
Maximum Run Time hrs	29	29
AC Distribution		
Circuit Breaker Size	450	450
Voltage Selection	3 position switch (lockable)	3 position switch (lockable)
Voltage Regulation.....	+/- 0.5%.....	+/- 0.5%
Voltages Available 1Ø	120, 139, 208, 220, 240, 277 ..	120, 139, 208, 220, 240, 277
Voltages Available 3Ø	208, 220, 440, 480	208, 220, 440, 480
Trailer		
Number of Axles.....	2	2
Capacity - Axle Rating lbs (kg)	6000 (2722).....	6000 (2722)
Tire Size in	16	16
Brakes.....	Surge.....	Surge
Hitch - Standard	3" ball	3" ball
Maximum Tire Pressure psi	75	75

GENERAC MODEL	MMG205DI4	MMG205DI4 Super Start
Engine		
Make/Brand.....	John Deere.....	John Deere
Model	PE6068HFG95.....	PE6068HFG95
EPA Tier	4i	4i
Horsepower - Prime hp (kW)	252 (188).....	252 (188)
Horsepower - Standby hp (kW)	268 (200).....	268 (200)
Operating Speed rpm	1800	1800
Displacement in³ (L)	415 (6.8).....	415 (6.8)
Cylinders - qty	6	6
Fuel Consumption - 100% Prime gph (Lph)	12.8 (48.5).....	12.8 (48.5)
Battery Type - Group Number.....	31	31
Battery Voltage (quantity per unit).....	12V (1)	12V (1)
Battery Rating	1000 CCA.....	1000 CCA
Generator		
Make/Brand.....	Marathon Electric	Marathon Electric
Model	431PSL6336	433PSL6216
Type, Insulation.....	Brushless, H.....	Brushless, H
Generator Set (Engine/Generator)		
3Ø - Standby kW (kVA)	174 (217).....	178 (222)
Amps - 3Ø Standby 480V (208V) A	261 (602).....	267 (616)
3Ø - Prime kW (kVA)	164 (205).....	166 (208)
Amps - 3Ø Prime 480V (208V) A	247 (569).....	250 (577)
1Ø - Standby kW (kVA)	155 (155).....	176 (176)
Amps - 1Ø Standby - 240V A	646	733
1Ø - Prime kW (kVA)	142 (142).....	167 (167)
Amps - 1Ø Prime - 240V A	592	696
Frequency Hz	60	60
Power Factor.....	1 (1Ø), 0.8 (3Ø).....	1 (1Ø), 0.8 (3Ø)
Sound dB(A) 23 ft @ prime	68	68
Weights		
Dry Weight, Skid Mounted lbs (kg)	6624 (3005).....	7444 (3377)
Operating Weight, Skid Mounted lbs (kg)	9052 (4106)	9872 (4478)
Dry Weight, Trailer Mounted* lbs (kg)	8020 (3638)	8840 (4010)
Operating Weight, Trailer Mounted* lbs (kg)	10448 (4739).....	11268 (5111)
*Standard trailer only. Consult factory for custom trailer weights.		
Capacities		
Fuel Tank Volume gal (L)	342 (1295).....	342 (1295)
Usable Fuel Volume gal (L)	313 (1185)	313 (1185)
Coolant (incl. engine) qt (L)	31.5 (29.8).....	31.5 (29.8)
Oil (incl. filter) qt (L)	33.0 (31.2).....	33.0 (31.2)
Maximum Run Time hrs	42	42
AC Distribution		
Circuit Breaker Size	800	800
Voltage Selection	3 position switch (lockable)	3 position switch (lockable)
Voltage Regulation.....	+/- 0.5%.....	+/- 0.5%
Voltages Available 1Ø	120, 139, 208, 220, 240, 277 ..	120, 139, 208, 220, 240, 277
Voltages Available 3Ø	208, 220, 440, 480	208, 220, 440, 480
Trailer		
Number of Axles.....	2	2
Capacity - Axle Rating lbs (kg)	6000 (2722).....	6000 (2722)
Tire Size in	16	16
Brakes.....	Surge.....	Surge
Hitch - Standard	3" ball	3" ball
Maximum Tire Pressure psi	75	75

Specifications are subject to change without notice.

Unit Dimensions

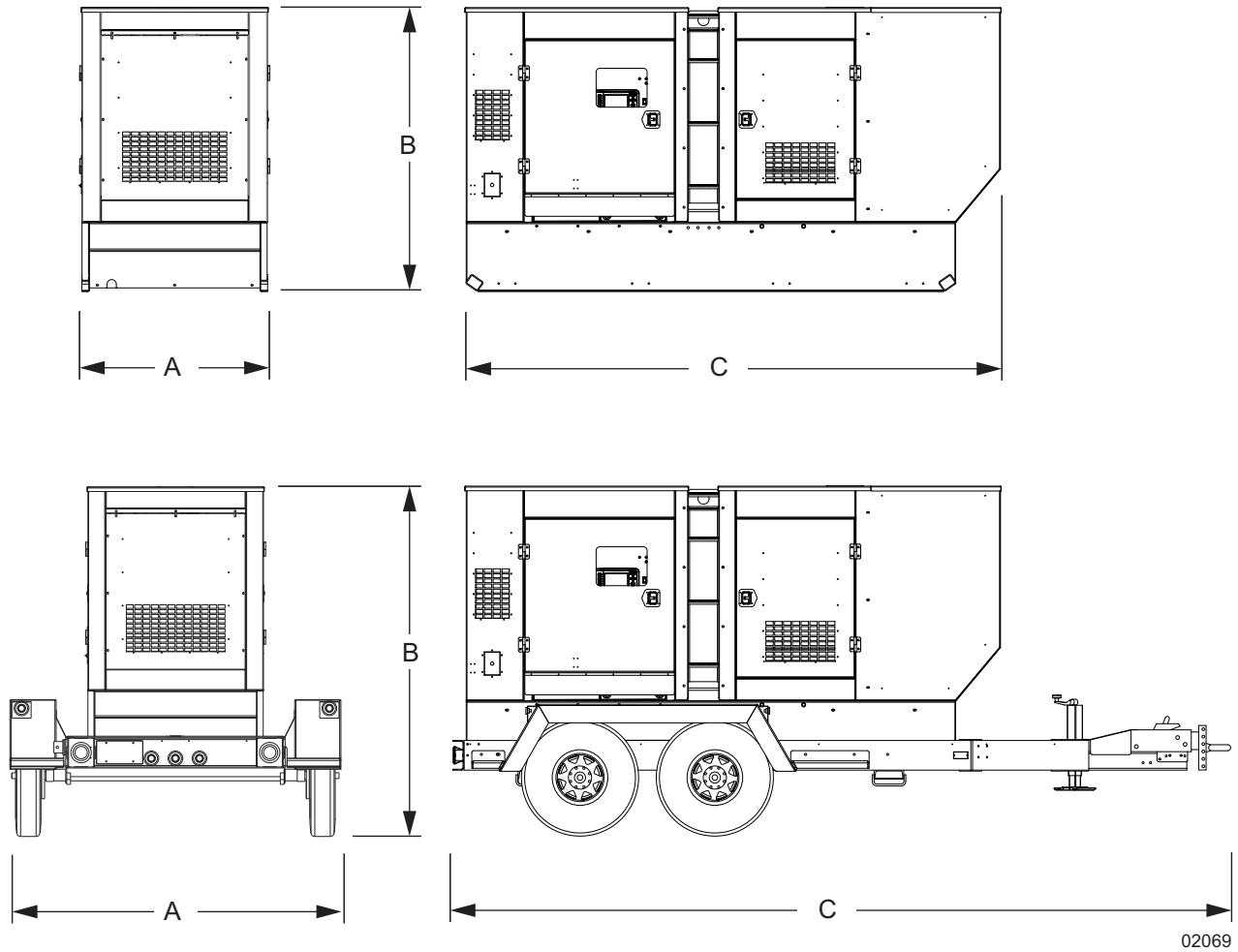

02069

Figure 2-1. Unit Dimensions

	A	B	C
MMG130DI4/175DI4/205DI4 - Skid Mounted	50 in. (1.27 m)	77 in. (1.96 m)	144 in. (3.66 m)
MMG130DI4/175DI4/205DI4 - Trailer Mounted	86 in. (2.18 m)	93 in. (2.36 m)	210 in. (5.33 m)

Specifications are subject to change without notice.

UNIT SERIAL NUMBER LOCATIONS

See **Figure 2-2** for unit ID tag and Vehicle Identification Number (VIN) tag on the unit. Important information, such as the unit serial number, model number, VIN and tire loading information are found on these tags. Record the information from these tags so it is available if the tags are lost or damaged. When ordering parts or requesting assistance, you may be asked to provide this information.

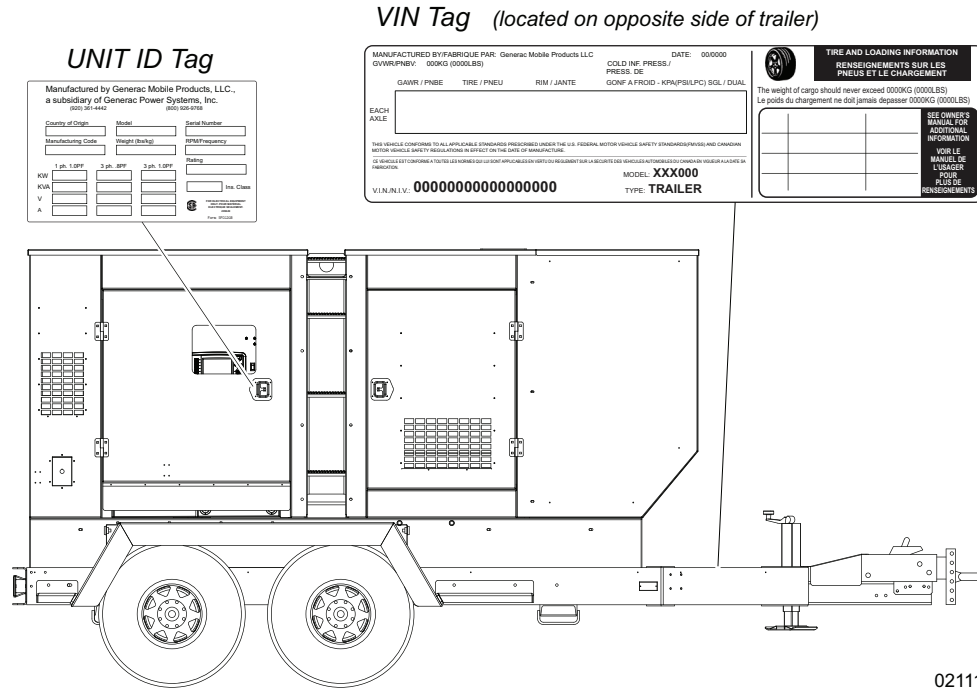

02111

Figure 2-2. Serial Number Locations

COMPONENT LOCATIONS

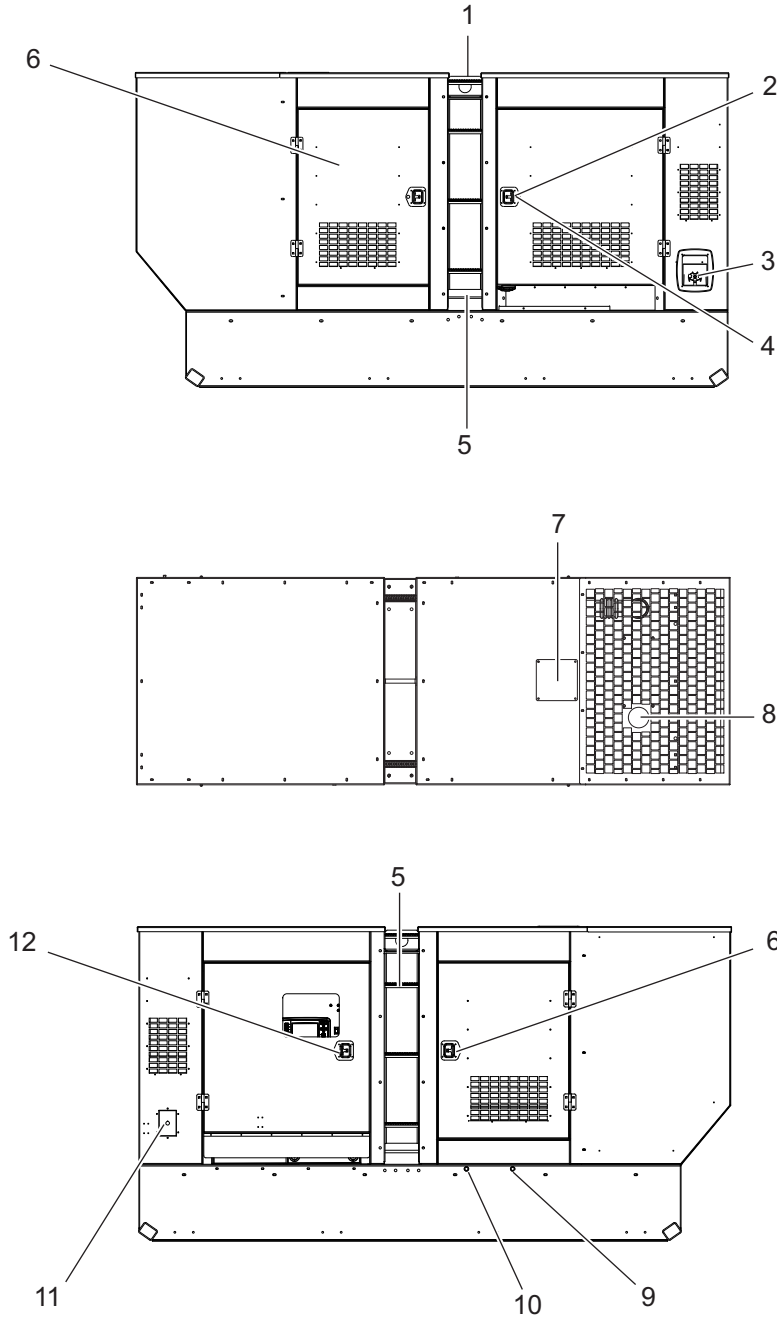

02112

Figure 2-3. Component Locations

- | | |
|----------------------------|--------------------------|
| 1. Central lift point | 7. Radiator access panel |
| 2. Voltage selector access | 8. Engine exhaust |
| 3. Fuel fill | 9. Radiator drain port |
| 4. Engine battery access | 10. Oil drain port |
| 5. Ladder | 11. Emergency stop |
| 6. Engine access | 12. Control panel access |

CONTROL PANEL

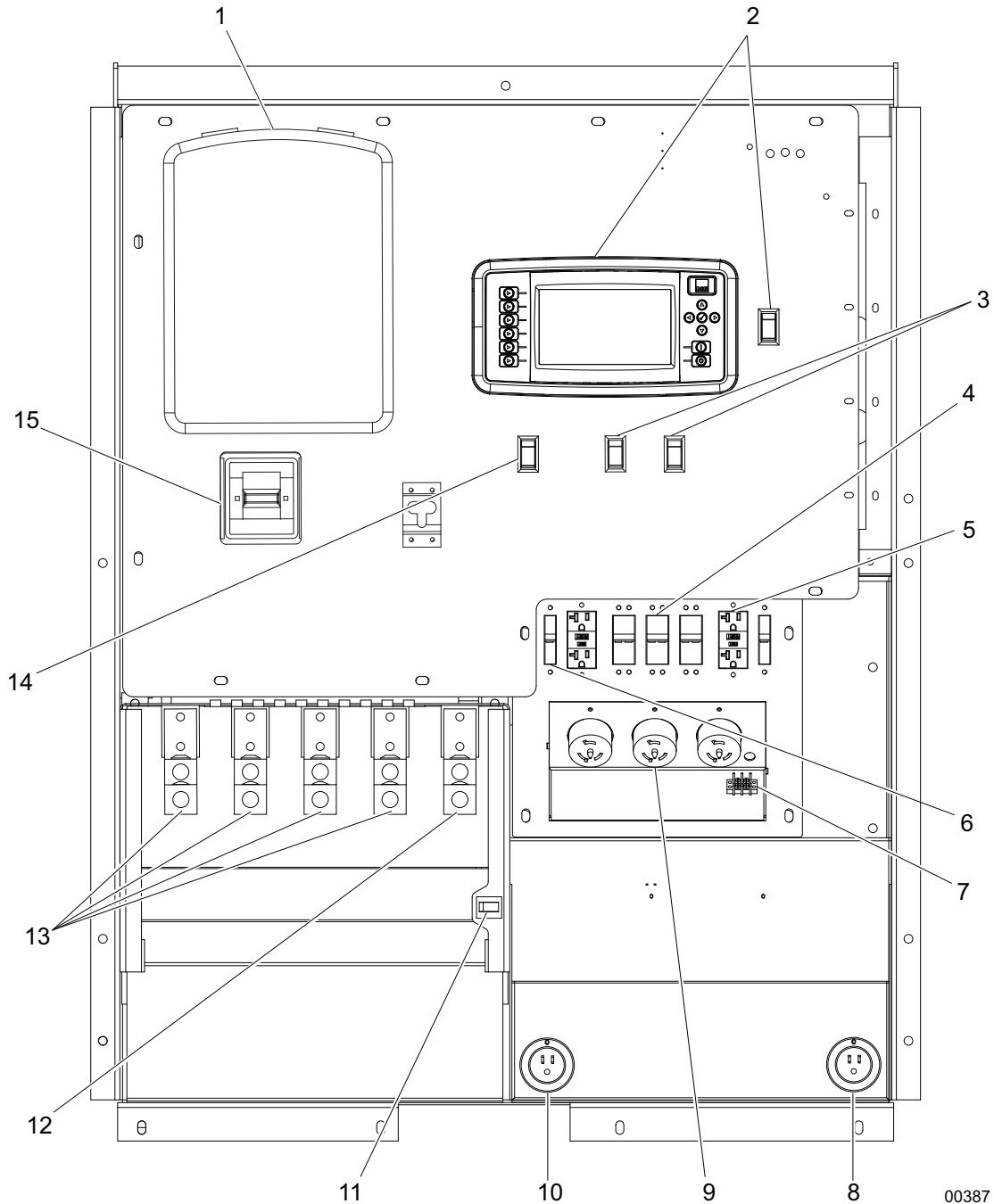
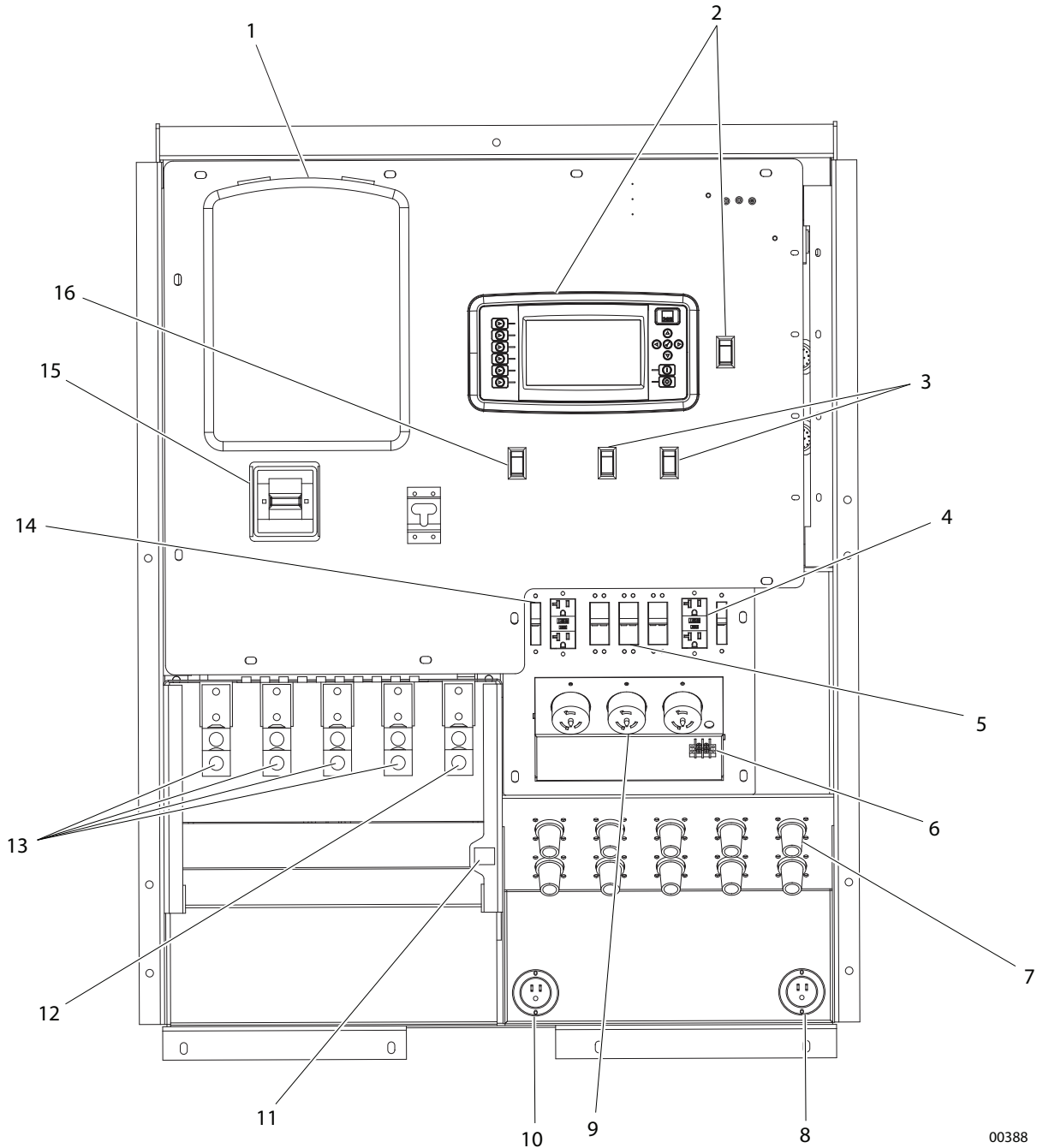

Figure 2-4. Control Panel Component Locations

- | | |
|--|---|
| 1. Document holder | 9. 120/240V twist-lock receptacles (3) |
| 2. Power Zone™ controller | 10. Connection for engine block heater (optional) |
| 3. Auxiliary light switches (2) (optional) | 11. Door safety switch |
| 4. 50A circuit breakers (3) | 12. Output ground connection |
| 5. 120V GFCI receptacles (2) | 13. Connection terminal lugs (4) |
| 6. 20A circuit breakers (2) | 14. Diesel exhaust filter cleaning switch |
| 7. Remote start terminal block | 15. Main circuit breaker for connection lugs |
| 8. Connection for battery charger (optional) | |

CONTROL PANEL - WITH CAM LOCK OPTION



00388

Figure 2-5. Control Panel Component Locations

- | | |
|--|---|
| 1. Document holder | 9. 120/240V twist-lock receptacles (3) |
| 2. Power Zone™ controller | 10. Connection for engine block heater (optional) |
| 3. Auxiliary light switches (2) (optional) | 11. Door safety switch |
| 4. 120V GFCI receptacles (2) | 12. Output ground connection |
| 5. 50A circuit breakers (3) | 13. Connection terminal lugs (4) |
| 6. Remote start terminal block | 14. 20A circuit breakers (2) |
| 7. Cam lock connectors (10) (optional) | 15. Main circuit breaker for connection lugs |
| 8. Connection for battery charger (optional) | 16. Diesel exhaust filter cleaning switch |

POWER ZONE™ CONTROLLER

The Power Zone™ controller is an auto start controller that monitors the unit and indicates operational status and fault conditions. The controller can be programmed to automatically start or stop based on time schedule, fault condition, or load demand.

The controller constantly monitors vital generator and engine functions for a number of preprogrammed alarm and fault conditions. When a fault condition occurs, the engine can be shut down automatically and the LCD window will show the fault that caused the shut down; to resume operation, the fault condition must be resolved.

This controller also records a history of unit performance which may be viewed at any time and will not be lost when the controller is powered down.

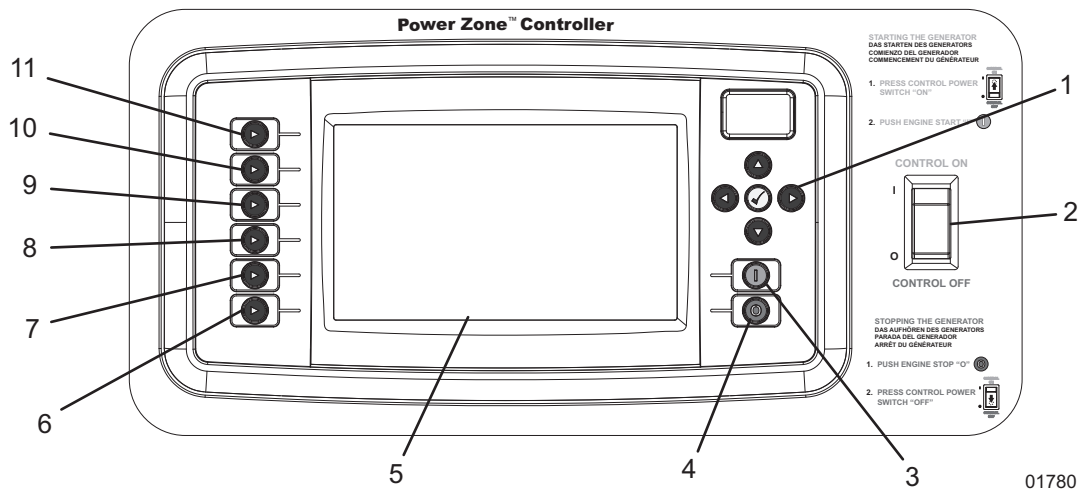

Figure 2-6. Power Zone™ Controller Layout

- | | |
|-------------------------------|-------------------|
| 1. Navigation buttons | 7. Alarm mute |
| 2. Control power switch | 8. Voltage adjust |
| 3. Engine start (manual mode) | 9. Generator |
| 4. Engine stop/reset | 10. Engine |
| 5. Main display | 11. Home |
| 6. Auto/manual mode | |

CONTROLLER FEATURES AND FUNCTIONS

Operator Screens

These buttons are used to enter the various operator screens from any other screen. The operator screens consist of four screens: Home (🏠), Engine (🚗), Generator (GEN), and Voltage Adjust (⚡). For information about the screens, refer to [Operator Screens](#).

Alarm Mute

The Alarm Mute (🔇) button silences the audible alarm. Additional action will be required to fully disable the active alarm.

Auto/Manual Mode

The Auto/Manual Mode (☐) button is used to change the startup and shutdown modes of the unit. When pressed once, the unit enters Manual mode and when pressed and held for five seconds, the unit enters Auto mode. If in Auto mode, pressing once will return the unit to Manual mode.

Navigation Buttons

These buttons are used to navigate and interact with the Power Zone™ controller screens. Pressing any directional arrow (▲, ►, ▼, ◀) while on any of the operator screens will open the maintenance screens, and navigate the tabs and pages within the maintenance screens. The Enter (✓) button is used to select menus, confirm alarms, and confirm altered settings.

Control Power Switch

Use this switch to start up and shut down the Power Zone™ controller. This switch should not be turned off when the unit is running.

Engine Start

Pressing the Engine Start (I) button while the controller is in Manual mode will start the unit, provided there are no shutdown errors, and the engine satisfies the start status. If the controller is in Auto mode, the Engine Start (I) button has no effect.

Engine Stop/Reset

Pressing the Engine Stop/Reset (O) button will shut down the unit and put the controller into Stop mode, whether in Manual mode or Auto mode.

▲ CAUTION

In case of an emergency, always press the emergency stop switch located on the side of the unit to stop the engine immediately. The Engine Stop/Reset (O) button may delay the engine shutdown if stop faults exist.

NOTICE

To prevent damage to the generator and connected equipment, remove all loads from the generator by opening all circuit breakers (turn OFF (O)) before pressing the Engine Stop/Reset (O) button.

The Liquid Crystal Display (LCD)

This window will display the various operator and maintenance screens. By viewing these screens, the operator will be able to monitor both the engine and generator status while the unit is running.

OPERATOR SCREENS

The operator screens display the most relevant and critical information an operator will need to properly configure and utilize a unit. From these four screens, the operator can access engine, generator and power transmission information necessary to operate the unit under normal conditions.

Home Screen

The Home screen is the default screen of the controller and will display after the controller is powered up and the

unit management software is loaded. It displays a live readout of the kW meter, percent of load used (gauge), selected phase, volts and amps being produced by the generator, and the fuel level with time until empty. The controller will automatically return to this screen from any other screen after a period of inactivity.

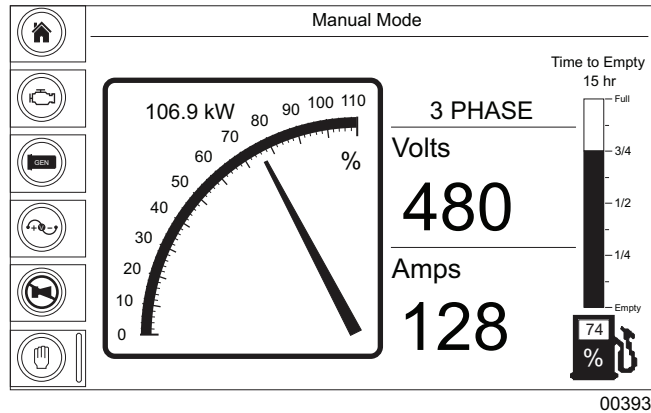

Figure 2-7. Home Screen

Engine Screen

The Engine screen displays the oil pressure, coolant temperature and battery voltage on three main gauges. Below the gauges is an hour gauge displaying the total run time on the engine. At the bottom of the screen, this screen also displays maintenance alarm status with the time remaining (black text) or the time past (red text) a scheduled maintenance tasks, along with the description of the maintenance procedure and the action that will take place when the timer trips the alarm.

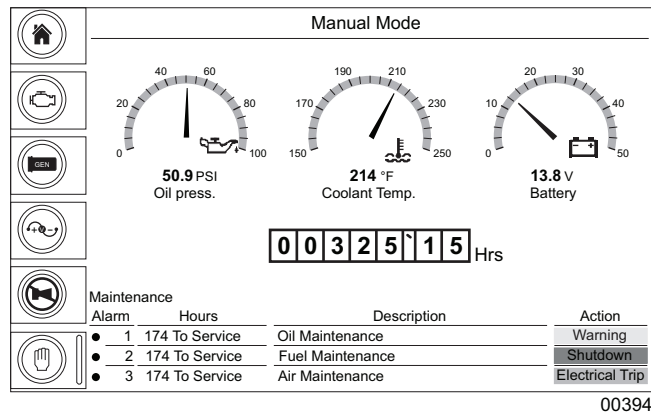

Figure 2-8. Engine Screen

Note: If the measured value is outside the range of a gauge, the needle will not be displayed. The digital value below the gauge will still show the measured value.

- **Oil Press:** Displays engine oil pressure. Current coolant temperature is displayed directly below the gauge at all times. The gauge registers oil pressure between 0-100 psi (0-689 kPa). Normal operating pressure is between 35-80 psi (241-552 kPa).
- **Coolant Temp:** Displays engine coolant temperature. Current coolant temperature is displayed directly below the gauge at all times. The gauge displays coolant temperature between 150°-250°F (66°-121°C). Normal operating temperature of the unit is between 180°-200°F (82°-93°C) with an average ambient air temperature of 70°F (21°C).

- **Battery:** Displays the engine battery voltage. Current battery voltage is displayed directly below the gauge at all times. The gauge displays battery voltage between 0-50V. A normal reading is 12-14V on 12 volt systems and 24-26V on 24 volt systems (with the engine running).

Generator Screen

The Generator screen displays the average voltage frequency, volts and amps from the generator, as well as line-to-line voltage, and individual line-to-neutral voltage, amperage and power (kW). This screen also displays the generator winding configuration set by the voltage selector switch in the lower right corner.

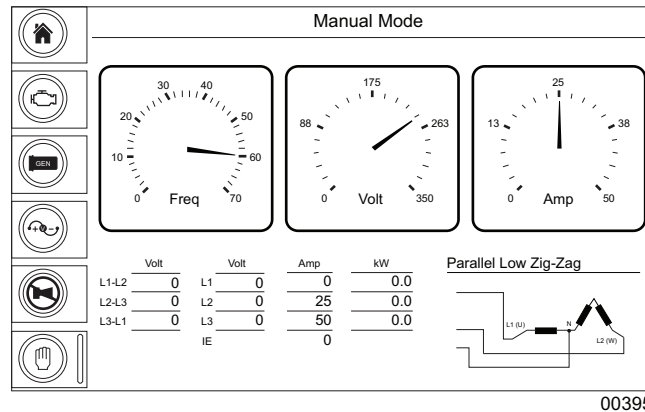

Figure 2-9. Generator Screen

Note: When loading the generator, it is important to observe the amperage to determine the load balance on each line of the generator. Minor load unbalances, usually ten percent or less, will not cause problems. Every effort should be made to distribute the load equally between all lines.

- **Freq:** Displays the output frequency in Hertz (Hz). Normal operating frequency is 60 Hz.
- **Volts:** Displays the nominal voltage in Volts (V).
- **Amps:** Displays the AC output amperage produced by the generator in Amps (A).

Additional information can be found on the electric power table at the bottom-left side of the screen. This provides an overview of all three lines and average voltage and amperage readouts.

Voltage Adjust Screen

The Voltage Adjust screen displays the line-to-neutral and line-to-line voltage averages. The operator can electronically adjust the voltage within limits to prevent under-voltage or over-voltage conditions using the on-screen instructions. This feature replaces a traditional potentiometer. See [Fine Voltage Adjustment](#) for more information.

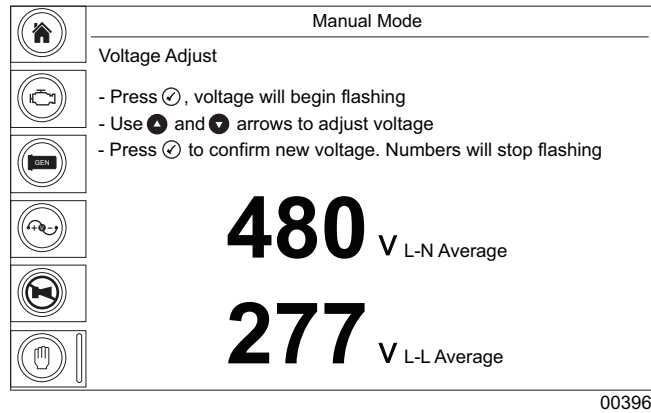

Figure 2-10. Voltage Adjust Screen

MAINTENANCE SCREENS

All of the data inputs from the engine, generator, inputs/outputs, schedule and Power Zone™ controller are visible on the maintenance screens.

The information displayed on the maintenance screens can be used to identify, diagnose and troubleshoot unit shutdown conditions and poor unit performance. The maintenance screens can be accessed from any Operator screen by pressing any directional arrow (▲, ►, ▼, ◀).

The bottom of the screens have a list of available tabs, with the currently displayed tab highlighted in blue. The tabs can be selected by using the ▲ or ▼ buttons. To the left of the tabs, the current/available pages are displayed. The pages within a tab can be viewed by using the ▲ and ▼ buttons. Whenever a new tab is selected, the current page will always be page 1.

Generator Summary

The Generator Summary can be found at the top of all maintenance screens and provides an overview of the system.

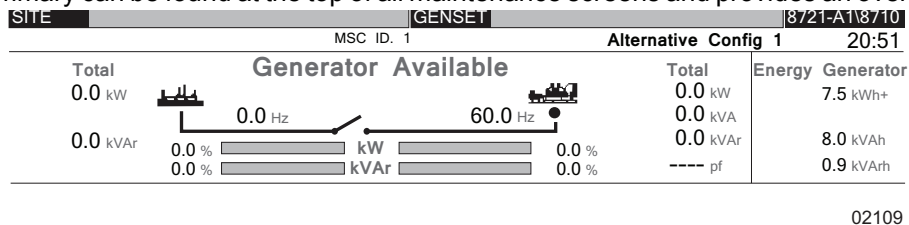

Figure 2-11. Generator Summary Screen

Engine Tab

The Engine tab contains maintenance and instrumentation data gathered from the engine itself. Above the engine analogue meters is a row of alarm icons. Each icon can be one of three colors: grey (inactive), yellow (warning) or red (shutdown). The alarm icons are as follows from left to right: water in fuel, emission filter, engine air inlet temperature, charge alternator, oil pressure, fuel level, battery voltage, coolant temperature, and ECU lamp.

Note: The content may change depending upon the selected engine and the features supported by the engine.

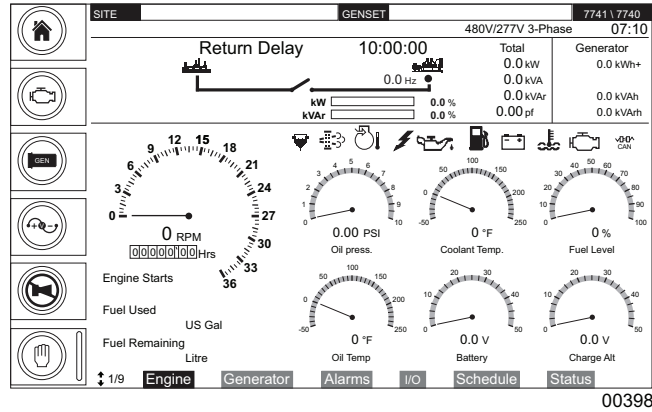

Figure 2-12. Engine Tab Screen

Generator Tab

The Generator tab contains maintenance and instrumentation data gathered from the generator. Each page highlights different data gathered by the generator with the analogue meters changing accordingly. The last two pages will display the information in the bar graph. The bar graph shows blue for positive and red for negative. For the power factor bar graph, blue is for lagging pf and red is for leading pf.

Note: The content may change depending upon the selected generator and the features supported by the generator.

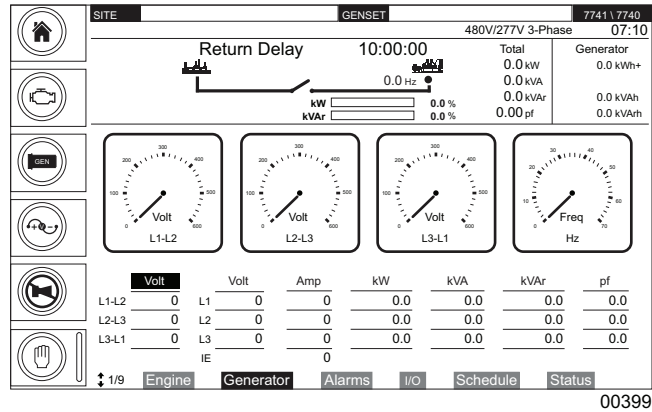

Figure 2-13. Generator Tab Screen

Alarms Tab

The Alarms tab displays warnings, electrical trip and shutdown alarms, and engine Diagnostic Trouble Codes (DTC) that are occurring or have occurred previously. The first page on the Alarms tab displays the alarms that are currently active. They are organized by alarm type.

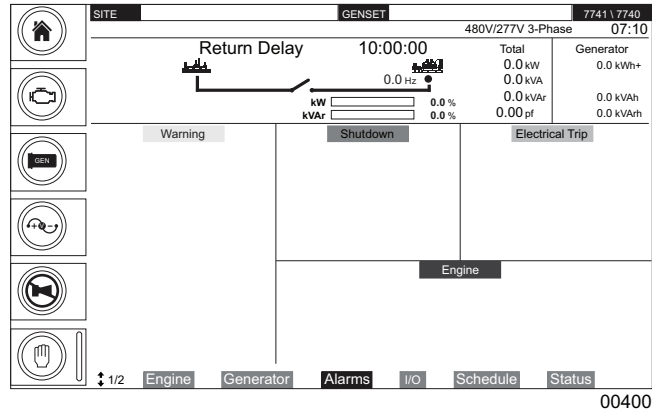

Figure 2-14. Alarms Tab Screen

Alarm Type	Color - Background/Text	Graphic
Warning	Yellow/Black	Warning
Electrical Trip	Purple/Black	Electrical Trip
Shutdown	Red/Black	Shutdown
ECU Code	Blue/White	Engine

The second page of the Alarms tab shows the event log with a list of events including normal operation events and alarm notifications with the most recent events at the top of the list. All indexed events include the date and time of the event, hours of runtime on the engine when it occurred, along with the event name or alarm type and details.

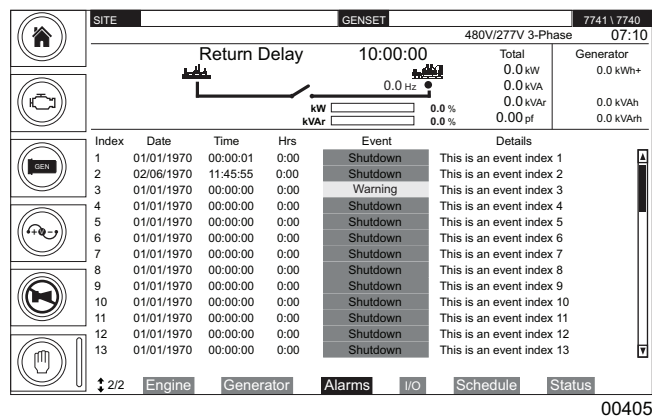

Figure 2-15. Alarms Tab Screen - Second Page

General Information

To scroll down within the event log, press the Enter (✓) button. The scroll bar will change to blue, signifying it is active. Press the ▲ or ▼ buttons to scroll up or down in the event log. When finished, press the Enter (✓) button again.

Input/Output Tab

The Input/Output (I/O) tab shows a list of digital inputs and outputs connected to the controller, whether they are active and the current state (open/closed status) of the input and output.

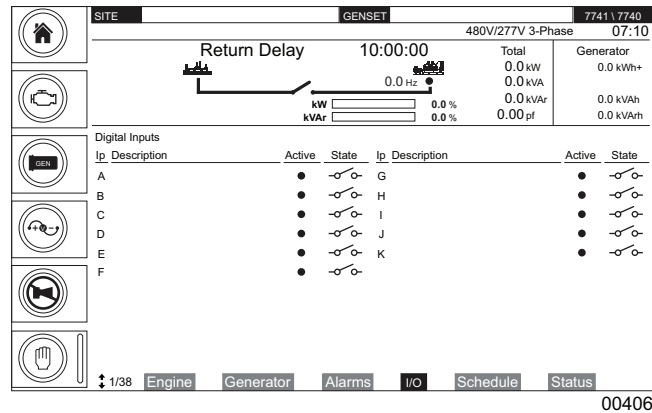

Figure 2-16. Input/Output Tab Screen

Schedule Tab

The Scheduler tab shows the current configuration and status of the scheduler, located below the generator summary. At the bottom of the screen, the maintenance configuration status and time remaining until an alarm, electrical trip or shutdown will occur. The lamp(s) to the left shows the configuration status of the maintenance alarm, not the alarm condition.

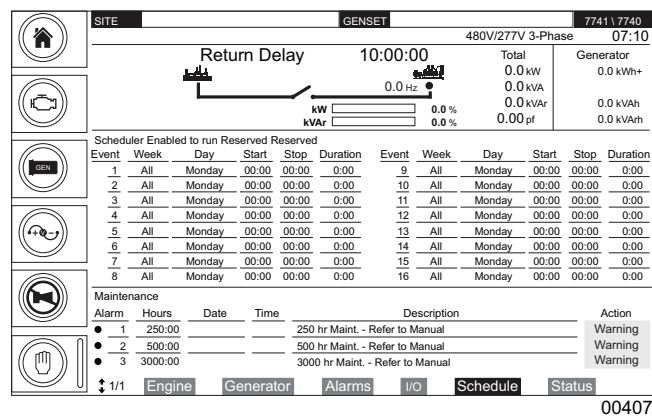

Figure 2-17. Schedule Tab Screen

Status Tab

The Status tab contains the status and configuration of the controller, firmware and data connections.

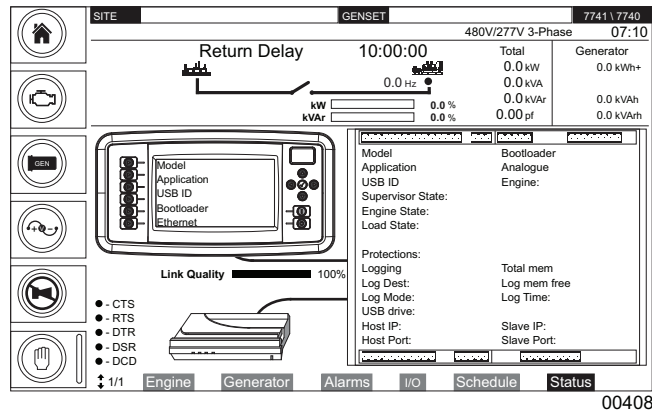

Figure 2-18. Status Tab Screen

GENERATOR MONITORING

Generator information is displayed on both the Generator operator screen and Generator tab within the maintenance screens. For more information, refer to [Operator Screens](#) and [Maintenance Screens](#).

ENGINE MONITORING

Engine information is displayed on both the Engine operator screen and Engine tab within the maintenance screens. For more information, see [Operator Screens](#) and [Maintenance Screens](#).

DIESEL EXHAUST FILTER MONITORING

This unit is equipped with a Diesel Particulate Filter (DPF) to meet current EPA emissions standards. This section gives an explanation of the indicators that are displayed on the DPF Status page of the Engine tab.

To access the DPF Status page, press any direction arrow (▲, ►, ▼, ◀) to enter the maintenance screens, and then while on the Engine tab, press the ▼ button to toggle through the pages until the DPF Status page appears. There are four areas on the DPF Status page that communicate various information to the operator. The areas and the indicators that appear in those areas are explained here:

- **HEST Lamp (High Exhaust System Temperature):** This area will display the Regeneration Underway indicator above the words “HEST Lamp - Solid” when the unit is in the process of diesel exhaust filter regeneration. During the regeneration process, the exhaust temperature will be very high.

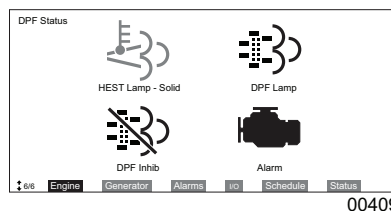

Figure 2-19. Regeneration Underway Indicator

- **DPF Lamp:** This area will display the Regeneration indicator above the words “DPF Lamp - Solid” when auto exhaust filter cleaning is enabled. When the unit is being operated with auto exhaust filter cleaning

disabled, the indicator will begin to flash above the words “DPF Lamp -Flashing” if the soot load level goes above 80%.

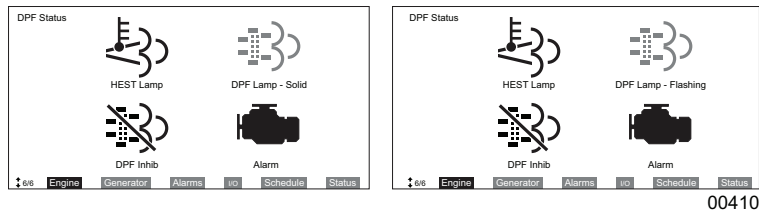

Figure 2-20. Regeneration Indicator

- **DPF Inhib:** This area will display the Disabled Regeneration indicator above the words “DPF Inhib - Solid” when auto exhaust filter cleaning is disabled.

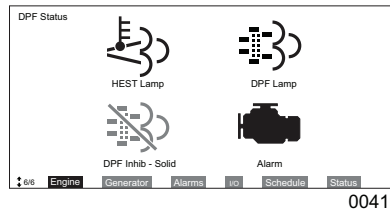

Figure 2-21. Disabled Regeneration Indicator

- **Alarm:** This area will display the Engine Alarm indicator above the words “Alarm - Solid” when an alarm condition occurs. This area displays different text depending upon which alarm condition occurs.

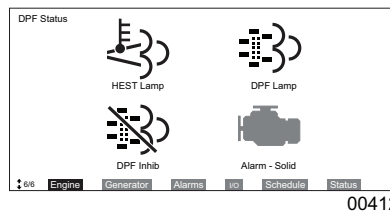

Figure 2-22. Engine Alarm Indicator

For more information on the operation of auto exhaust filter regeneration and service regeneration, see [Exhaust Filter Cleaning Operations](#).

POWER ZONE™ CONTROLLER INFORMATION DISPLAYS, FUNCTIONS, AND RESET

The Power Zone™ controller constantly monitors vital generator and engine functions for a number of operation, alarm and fault conditions. When a fault condition occurs, the engine will shut down automatically and the main display will show the fault that has caused the shutdown. To resume operation, the fault condition must be resolved. To reset the controller and resume operation, press the Enter (✓) button.

BELT TENSIONERS

John Deere engines use two types of belt tensioners: manual and automatic. Adjust the belt using the manual tensioner according to the manufacturer’s specifications. The automatic tensioner cannot be adjusted or repaired and is designed to maintain proper tension over the life of the belt. Units with the automatic belt tensioner must be inspected according to the manufacturer’s specifications.

Section 3 - Operation

PRESTART CHECKLIST

Before starting the unit, all items in the prestart checklist must be completed. This checklist applies to both manual and remote starting of the unit.

- Read and understand **ALL** safety sections at the beginning of this manual.
- Verify all maintenance procedures are up to date. For more information, refer to **General Maintenance** and **Basic Maintenance Schedule - John Deere Engine**.
- The unit must be level.
- The unit must be dry. Verify if any water is inside, on, or near the unit; dry if needed.
- For grounding requirements, follow any local, state, or National Electrical Code (NEC) guidelines.
- Verify the Control Power switch is OFF (O).
- Verify all circuit breakers are OFF (O).
- Inspect all electrical cords; repair or replace any that are cut, worn, or bare.
- Verify oil, coolant, and fuel levels. For more information, refer to **General Maintenance**.
- Verify battery connections are secure.
- Turn the battery disconnect switch on, if equipped.
- Verify the engine fan belt tension and condition.
- Verify the engine fan belt guard.
- Verify the engine exhaust system for loose or rusted components.
- Verify all covers are in place and secure.
- Verify all electrical connections at the connection lugs, if equipped, are tight and wired correctly.
- Verify the voltage selector switch is set to the desired voltage and locked.
- Verify the emergency stop switch is pulled out.
- Verify the radiator and surrounding shroud are clear of debris.

MANUALLY STARTING THE UNIT

All units equipped with the Power Zone™ controller will initially start up in Stop mode. Use the following procedure to start the generator in Manual mode:

1. Move the Control Power switch to ON (I).

⚠ DANGER

CARBON MONOXIDE: USING A GENERATOR INDOORS CAN KILL YOU IN MINUTES.

2. The LCD window will show the prestart diagnosis and the controller will load the unit management software.

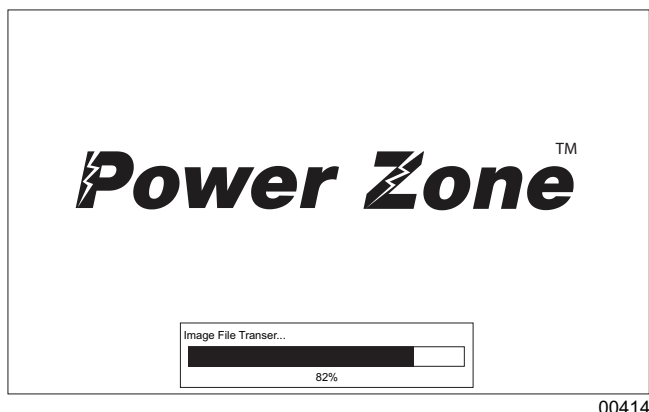

Figure 3-1. Startup Screen

- When the software is loaded, the Home screen will be displayed and the controller will be in Stop mode as indicated at the top of the screen. Press the Auto/Manual Mode (☐) button to enter Manual mode.

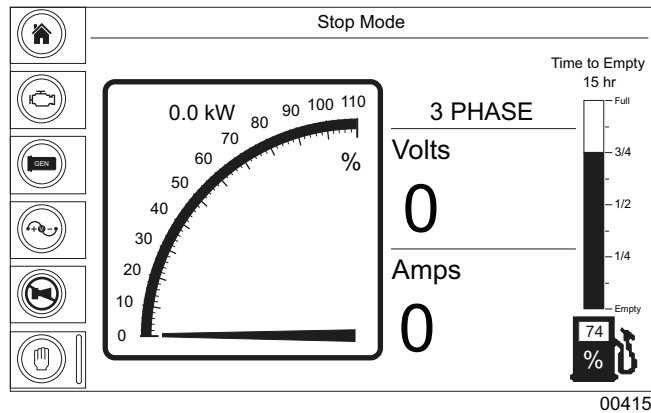

Figure 3-2. Home Screen

Note: The controller can be started from any screen when it is in Manual mode.

- Pressing the green Engine Start (I) button on the controller will initiate the startup procedure and start the engine, provided there are no engine faults preventing the unit from starting.

Note: It may take a few seconds for the engine to run smoothly and reach its governed operating speed. During this time, the screen will show a voltage different from that set with the voltage selector switch.

- If the engine does not start after the first cranking attempt, the engine will pause for 15 seconds to allow the starter to cool. The LCD window will show “Manual Mode - Crank Rest” at the top of the screen. The engine will make two more attempts to start for a total of three crank cycles.
- Should the engine not start and run within three starting cycles, the LCD window will show the “Fail to Start” alarm. The starting sequence may be repeated after the starter has had a minimum of two minutes to cool. Pressing the Enter (✓) button will clear the alarm and reset the controller.

Note: The engine controller may skip the preheat engine steps on some of the larger models.

- Once the engine starts, it will immediately begin speeding up to a constant 1800 rpm. The engine may hunt or change speeds until operating speed is reached. After a few minutes of operation, the engine will be warmed up and the operator screens will show engine and generator operating parameters.
- Check the generator for excessive noise or vibration and any coolant, oil, or fuel leaks before applying any loads.
- Check that the AC output voltage is correct. The output voltage can be fine adjusted by using the Voltage Adjust screen as described on [Fine Voltage Adjustment](#).
- Check that the frequency (Hz) is correct on the Generator screen. With no loads connected to the generator, the frequency should read approximately 60 Hz, depending on the type of engine governing used.
- If all wiring connections have been made correctly, switch the main circuit breaker to ON (I) and then add any loads attached to the receptacles by switching the respective circuit breaker to ON (I). You will notice a slight change in engine sound when a load is applied to the unit.

AUTO (REMOTE) STARTING OF THE UNIT

Auto mode is used when the unit is started from a location other than the control panel by using a transfer switch. Auto (remote start) is the normal setting when the unit is being used as a standby power supply. Before putting the unit in the Auto mode, review the [Prestart Checklist](#) and [Manually Starting the Unit](#). Also follow all safety warnings and information on isolating the generator with a transfer switch if the unit is to be used as a standby power supply. Refer to [Transfer Switch](#). Then continue with the steps described below:

1. Perform a manual start of the unit at least once to verify that the engine is operating correctly.
2. If a check of the remote start circuit is desired, remove the wires from the remote start terminal block. Press the Auto/Manual Mode (⏻) button, the LCD window should show “Auto Mode” at the top of the screen. Attach a jumper wire (minimum 16 gauge) across the two terminals on the remote start terminal block. This applies a ground to the Power Zone™ Controller to close the starting circuit contacts. The engine should crank, start and run.
3. Remove the jumper wire from the remote start terminal block and the engine will stop. Reconnect any necessary wires from the remote start switch (transfer switch) to the remote start terminal block.
4. Confirm the unit is in Auto mode. The LCD window should show “Auto Mode” at the top of the screen.
5. Close the main circuit breaker (set to ON (I)).
6. Secure the unit by closing and locking all access doors.
7. The unit is now ready for remote starting.

The remote start terminal block provides a connection for installation of a remote start switch which will allow the unit to be started by a remote dry-contact closure switch. For location of the remote start terminal block, refer to [Control Panel](#).

Before entering Auto mode, verify that the contacts on any remote switch linked to the unit are **OPEN**. If the contacts on a remote switch are closed, the engine will crank and start when Auto mode is entered. Attach the switch leads to the two unused terminals on the unit’s remote start terminal block.

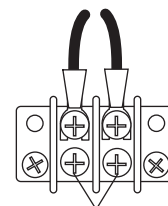

Remote Start
Switch Terminals 00231

Figure 3-3. Remote Start Terminal Block

DERATING FOR ALTITUDE

All units are subject to derating for altitude and temperature; this will reduce the available power for operating tools and accessories connected to the receptacles. Typical reductions in performance are 2-4% for every 1000 ft (305 m) of elevation and 1% per 10°F (5.6°C) increase in ambient air temperature over 72°F (22°C).

GENERATOR OUTPUT CONNECTIONS

The unit is equipped with connection lugs, located on the lower portion of the control box behind the lug box door. The lugs provide connection points for attachment of external loads to the generator. A large decal on the inside of the connection lug door details the proper connections for selected voltages.

⚠ WARNING

It is HIGHLY RECOMMENDED that only a trained and licensed electrician perform any wiring and related connections to the generator. Installation should be in compliance with the National Electrical Code (NEC), state and local regulations. Failure to follow proper installation requirements may result in equipment or property damage, personal injury, or death.

⚠ WARNING

Before any connections are made to the generator, make sure that the main circuit breaker and the Control Power switch are OFF (O). Potentially lethal voltages may be present at the generator connection lugs.

⚠ DANGER

IMPROPER OR INCORRECT CONNECTIONS TO A BUILDING'S ELECTRICAL SYSTEM CAN CAUSE POTENTIALLY LETHAL VOLTAGES TO BACKFEED INTO UTILITY LINES. THIS MAY RESULT IN INJURY OR ELECTROCUTION TO UTILITY WORKERS NEARBY. MAKE SURE THE GENERATOR IS SUPPLYING POWER TO AN ISOLATED OBJECT OR BUILDING THAT IS NOT CONNECTED TO ANY UTILITY LINES.

Connections to the lugs should be made by running the power cables up through the opening in the bottom of the box. **DO NOT** make any connections directly to the lugs without routing the cables through the opening. Use a hex-wrench to tighten the cable connections. The connection lug door is equipped with safety interlock switches that will trip the main circuit breaker and disable the voltage regulator, if the door is opened while the unit is operating.

⚠ WARNING

Never attempt to disable or modify the lug door safety switch(es). Equipment damage, personal injury or death may result.

A ground connection is located next to the connection lugs. The unit **MUST** be connected to a good earthen ground for proper operating safety. The generator neutral is bonded to ground when it is shipped from the factory. The bonding plate will need to be removed when the generator is used as a standby power source. **INSTALLATION SHOULD BE IN COMPLIANCE WITH THE NATIONAL ELECTRICAL CODE (NEC), STATE AND LOCAL REGULATIONS.**

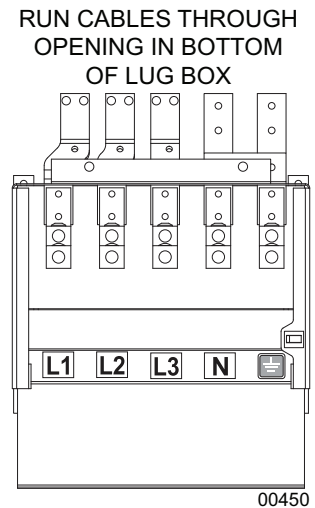

Figure 3-4. Connection Lugs

GENERATOR CAM LOCK CONNECTION(S) OPTION

The unit may be equipped with cam lock connections located below the receptacles. These receptacles provide connection points for the attachment of external loads to the generator. A decal below the cam lock connections details the proper connections for selected voltages.

⚠ WARNING

It is **HIGHLY RECOMMENDED** that only a trained and licensed electrician perform any wiring and related connections to the generator. Installation should be in compliance with the National Electrical Code (NEC), state and local regulations. Failure to follow proper installation requirements may result in equipment or property damage, personal injury or death.

⚠ WARNING

Before any connections are made to the generator, make sure that the main circuit breaker and the Control Power switch are OFF (O) and the negative (-) battery cable is disconnected. Potentially lethal voltages may be present at the generator connection lugs.

⚠ DANGER

IMPROPER OR INCORRECT CONNECTIONS TO A BUILDING'S ELECTRICAL SYSTEM CAN CAUSE POTENTIALLY LETHAL VOLTAGE TO BACKFEED INTO UTILITY LINES. THIS MAY RESULT IN INJURY OR ELECTROCUTION TO UTILITY WORKERS NEARBY. MAKE SURE THE GENERATOR IS SUPPLYING POWER TO AN ISOLATED OBJECT OR BUILDING THAT IS NOT CONNECTED TO ANY UTILITY LINES.

Connections should be made by plugging power cables equipped with series 16 taper nose 400A/600V cam lock plugs into the cam lock receptacles. Secure the connection by rotating the plug a 1/2 turn to the right.

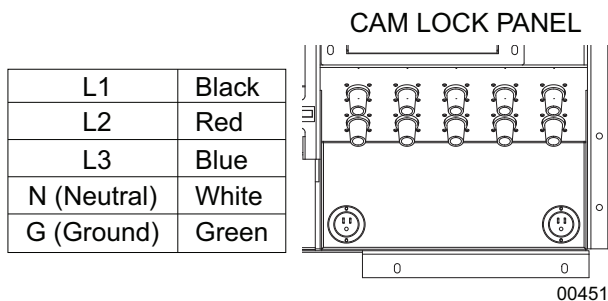

Figure 3-5. Cam Lock Connections

⚠ WARNING

NEVER attempt to disable or modify the lug door safety switches. Equipment damage, personal injury or death may result.

A ground connection is located on the far right of the cam lock panel. The unit **MUST** be connected to a good earthen ground for proper operating safety. The generator neutral is bonded to ground when it is shipped from the factory. The bonding plate will need to be removed when the generator is used as a standby power source. **INSTALLATION SHOULD BE IN COMPLIANCE WITH THE NATIONAL ELECTRICAL CODE (NEC), STATE AND LOCAL REGULATIONS.**

⚠ WARNING

Some units are equipped with two sets of cam lock connections. Make sure all connections to the cam lock receptacles are made to one side only, below each corresponding breaker. *i.e.* DO NOT attach L1, L2 and L3 to the left side and Neutral and Ground to the right side.

FINE VOLTAGE ADJUSTMENT

Adjustment of the output voltage from the generator is necessary to provide the correct voltage to the end of the power line. Voltage adjustment can be carried out at any time on the Voltage Adjust screen.

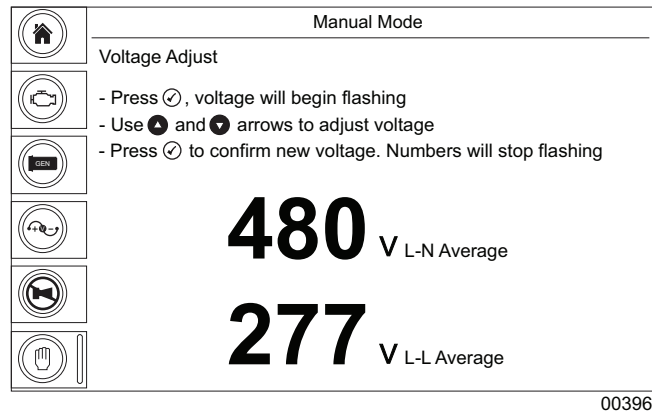



Figure 3-6. Fine Voltage Adjustment

1. With the unit running, press .
2. Press ✓. The voltages displayed will begin flashing.
3. Use ▲ and ▼ to adjust the voltage.
4. Press ✓ to confirm the new voltage. The voltages displayed will stop flashing.

VOLTAGE SELECTOR SWITCH

The voltage selector switch mechanically changes the connections between the generator output leads and the connection lugs on the main control panel. Voltage ranges are selected by rotating the handle on the switch to the desired voltage.

NOTICE

NEVER change the voltage selector switch while the engine is running or the controller is on. If the engine is running or starts while the setting is changed, severe arcing will occur causing damage to the switch and generator windings.

The voltage selector switch is equipped with a lockout mechanism. Once the proper voltage has been selected, insert a padlock through the lockout hole(s). By locking the handle in place, unauthorized changing of the voltage setting is prevented.

277/480V 3-PHASE

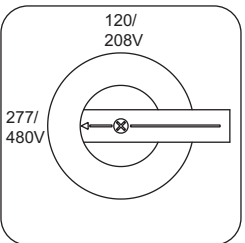

Switch styles vary by model.

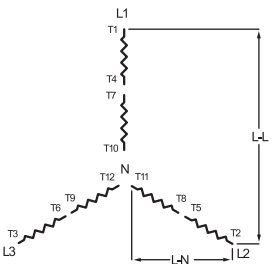

L1-L2 = 480V L1-N = 277V N = \perp

L2-L3 = 480V L2-N = 277V

L3-L1 = 480V L3-N = 277V

VOLTAGES AT RECEPTACLES		
RECEPTACLE	L-L	L-N
GFCI	-	139V
GFCI w/Buck	-	120V
Twist-locks	240V	139V

= Not recommended for normal use 00083

120/208V 3-PHASE

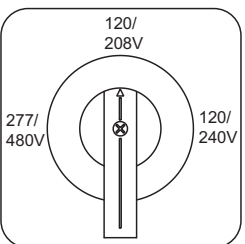

Switch styles vary by model.

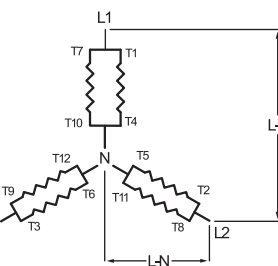

L1-L2 = 208V L1-N = 120V N = \perp

L2-L3 = 208V L2-N = 120V

L3-L1 = 208V L3-N = 120V

VOLTAGES AT RECEPTACLES		
RECEPTACLE	L-L	L-N
GFCI	-	120V
GFCI w/Buck	-	120V
Twist-locks	208V	120V

00085

120/240V 3-PHASE

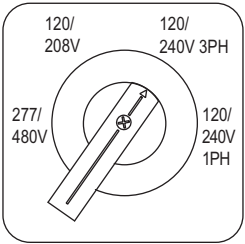

Switch styles vary by model.

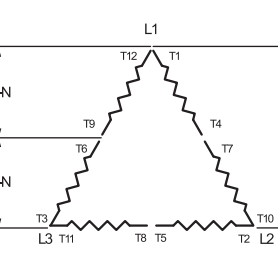

L1-L2 = 240V L1-N = 120V N = \perp

L2-L3 = 240V L2-N = 208V

L3-L1 = 240V L3-N = 120V

VOLTAGES AT RECEPTACLES		
RECEPTACLE	L-L	L-N
GFCI	-	120V
GFCI w/Buck	-	120V
Twist-locks	120V	0/120V

4 Position Voltage Selector Switch Option

= Not recommended for normal use 00086

120/240V 1-PHASE

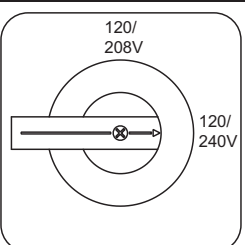

Switch styles vary by model.

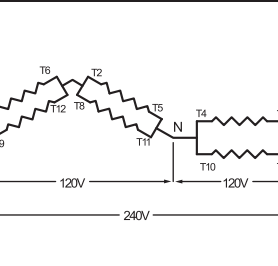

L1-L2 = - L1-N = 120V N = \perp

L2-L3 = - L2-N = -

L3-L1 = 240V L3-N = 120V

VOLTAGES AT RECEPTACLES		
RECEPTACLE	L-L	L-N
GFCI	-	120V
GFCI w/Buck	-	120V
Twist-locks	240V	120V

00087

= Not recommended for normal use.

Figure 3-7. Voltage Selector Switch

VOLTAGE REGULATOR

The electronic voltage regulator controls the output of the generator by regulating the current into the exciter field. The regulator has four screwdriver adjustable potentiometers that may be adjusted for U/F dip, under frequency protection (U/F), stability, and voltage. The voltage regulator on the unit is adjusted before shipment from the factory. Contact Generac Mobile Products LLC for additional information before attempting to adjust the voltage regulator.

Note: For units equipped with a Marathon DVR2000E+ digital voltage regulator, please refer to the Marathon operating manual provided with the unit.

CUSTOMER CONVENIENCE RECEPTACLES

The unit is equipped with five receptacles. The large receptacles are 240/120VAC twist-lock receptacles rated at 50A each. The smaller duplex receptacles are 120VAC rated at 20A each with ground fault circuit interrupt (GFCI) protection. These receptacles are not routed through the main circuit breaker. Each receptacle has its own circuit breaker, located directly above or next to the receptacle. Each breaker is sized to the maximum rating of the corresponding receptacle.

NOTICE

Power to the receptacles is available any time the generator is running, **EVEN IF THE MAIN CIRCUIT BREAKER IS OFF (O) VERIFY ANY EQUIPMENT CONNECTED TO THE RECEPTACLES IS TURNED OFF BEFORE TURNING THE BREAKERS ON.** Verify the voltage selector switch is in the proper position and that the output voltage is correct for the equipment that is connected to the receptacles. Improper voltage may cause equipment damage or malfunction.

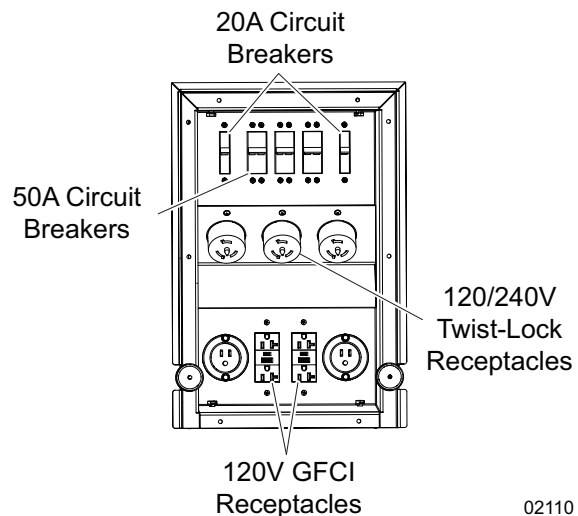

Figure 3-8. Receptacle and Breaker Locations

02110

Note: When the voltage selector switch is in position for 480/277V 3Ø, voltage at the two GFCI receptacles is 139 volts and the voltage at the three twist-lock receptacles is 240/139 volts. Generac Mobile Products LLC does not recommend using the receptacles in the 480V position. When the voltage selector switch is in position for 208/120V 3Ø, voltage at the three twist-lock receptacles and the two GFCI receptacles is 208/120 volts.

MAIN CIRCUIT BREAKER

The main circuit breaker is located on the main control panel. When the breaker is OFF (O), power is interrupted between the connection lugs, the optional cam lock receptacles, and the generator. Once the connections have been made to the connection lugs or the optional cam lock receptacles, and the unit has been started and allowed to reach normal operating temperature, the breaker may be switched ON (I).

The main circuit breaker will be tripped, disconnecting power to the connection lugs and the optional cam lock receptacles if any of the following items occur while the unit is running:

1. Overload of the generator circuits to the connection lugs or the optional cam lock receptacles (208/120V only).
2. The door covering the connection lugs or the optional cam lock receptacles is opened.
3. If the emergency stop switch is activated.
4. **LARGE MMG** - If the door to the reconnect box (link board) is removed.

Make sure any problems that cause the main circuit breaker to trip are corrected before turning the switch ON (I).

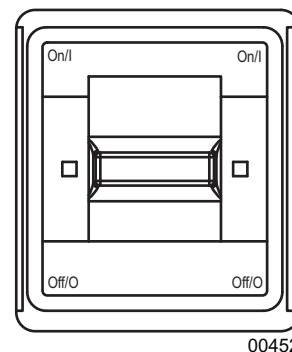

Figure 3-9. Main Breaker

NOTICE

The main circuit breaker interrupts power to the connection lugs and the optional cam lock receptacles only. The control panel receptacles have power even if the main circuit breaker is OFF (O). To disconnect power to these receptacles, use the individual circuit breakers located near each receptacle.

EXHAUST FILTER CLEANING OPERATIONS

When enabled, the exhaust filter system goes through an automatic cleaning process known as regeneration. Under normal circumstances, regeneration occurs without interruption of unit operation and with minimal operator involvement. In the event there are conditions requiring the operation of the unit with the auto exhaust filter cleaning disabled, the operator may be required to perform procedures to enable or disable the auto exhaust filter cleaning. The operator may also be required to perform a manual regeneration. The following procedures describe how to perform these functions.

▲ WARNING

The area above and surrounding the exhaust system during an auto or manual exhaust filter cleaning should be clear of any people and objects. Exhaust gases and components can reach temperatures hot enough to ignite and melt common materials.

Note: Always park the unit in a safe location for elevated exhaust temperatures and check for adequate fuel level before beginning the exhaust filter cleaning process. The cleaning cycle can take an extended period of time (approximately 45 minutes). Cleaning is complete when the Regeneration indicator remains off.

TRANSFER SWITCH

NOTICE

The generator neutral is bonded to ground when shipped from the factory. The bonding plate will need to be removed when the generator is used as a standby power supply. Installation should be in compliance with the National Electrical Code (NEC), state and local regulations.

When the generator is used as a standby power supply, it must be equipped with a transfer switch which isolates it from the utility's distribution system. A transfer switch is designed to transfer electrical loads from the normal power source (utility) to the emergency power source (generator) when normal voltage falls below a prescribed level. The transfer switch automatically returns the load back to the normal source when power is restored back to operating levels.

⚠ DANGER

FAILURE TO ISOLATE THE GENERATOR FROM THE NORMAL POWER UTILITY CAN CAUSE POTENTIALLY LETHAL VOLTAGE TO BACKFEED INTO THE UTILITY LINES. THIS MAY RESULT IN INJURY OR ELECTROCUTION OF UTILITY WORKERS NEARBY. MAKE SURE THE GENERATOR IS ISOLATED BY A TRANSFER SWITCH FROM ANY LOCAL UTILITY LINES. THIS ALSO APPLIES IF THE GENERATOR IS BEING USED AS A BACKUP TO SOME OTHER TYPE OF POWER SUPPLY.

Installation of a transfer switch or other type of remote starting device is the responsibility of the generator user. Installation of such devices must be performed by following all directions supplied by the manufacturer of the switch. If attaching the generator to a power supply normally serviced by a utility company, notify the utility company and check state and local regulations. Familiarize yourself with all instructions and warning labels supplied with the switch.

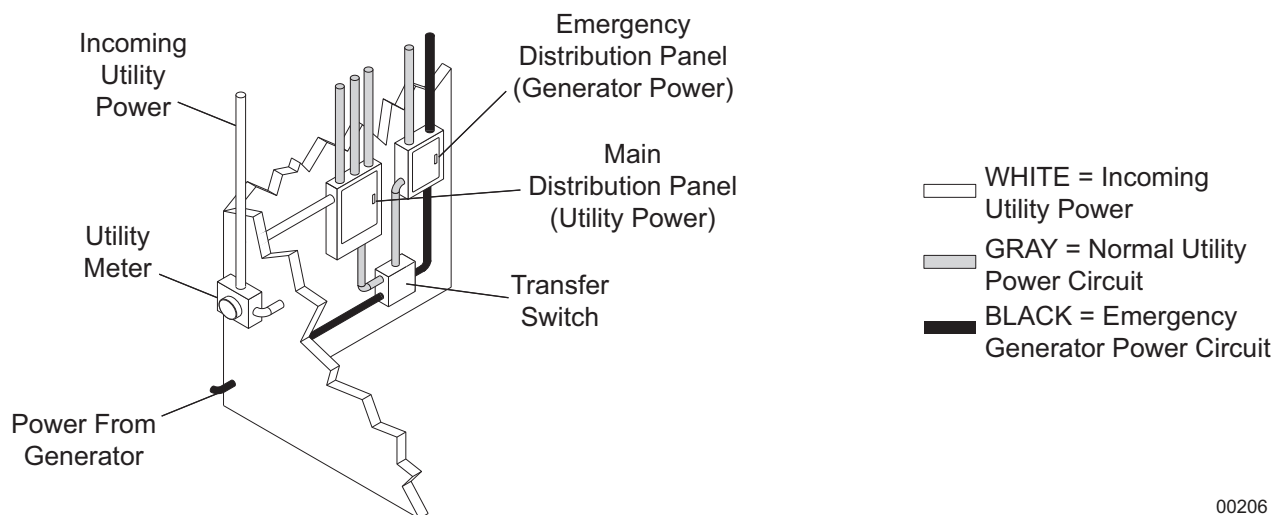

00206

Figure 3-10. Transfer Switch Operation

⚠ WARNING

ONLY a licensed electrician should perform wiring or related connections to the generator. Installation should be in compliance with the National Electrical Code (NEC), state and local regulations. Failure to follow these procedures could result in property damage, personal injury or death. Before any connections are attempted, verify the main circuit breaker and the Control Power switch are OFF (O) and that the negative (-) battery cable has been disconnected from the engine starting battery.

NOTICE

When using the generator as a standby or substitute power supply, make sure the output voltage and phase rotation of the generator match those of the local power utility. Improper voltage or phase rotation may cause equipment damage or malfunction.

AUTO EXERCISE TIMER

The Power Zone™ controller is capable of starting and stopping the unit automatically, based on a programmable schedule.

Units installed in a standby application should be exercised regularly to maintain operating condition and to ensure responsiveness in an emergency situation. Use the following procedures to operate the unit in Auto mode:

Accessing the Configuration Menu

1. With the unit stopped, press ▲, ►, ▼, or ◀ to navigate to the maintenance screens from any of the operator screens.
2. While on any maintenance screen, press ✓ and O simultaneously. The controller will display the Configuration menu.
3. To save any changes and exit the Configuration menu, press and hold ✓ for five seconds. To cancel any changes and return to the maintenance screen, press and hold O for five seconds.

Set the Controller Clock

The schedule runs based off the time set in the controller clock. Use the following procedure to set the controller clock **BEFORE** setting the schedule:

1. Navigate to the Maintenance group and press ► to access it.
2. Press ► to select the Time section.
3. Set the time and date to the correct local time.

Set the Schedule

1. Access the Scheduler group by pressing the ► button.

Note: The Scheduler group is made up of the Scheduler Options and Scheduler Setup sections. Each section can be accessed and exited using the ► and ◀ buttons.

2. Access the Scheduler Options section. Within this section, the scheduler can be enabled, run mode selected, and load mode selected.

Item	Values
Enable	Yes/No
Run Mode	Monthly/Weekly
Load	Idle, In Island, On Load, Off Load

3. Access the Scheduler Setup section. Within this section, each schedule entry can be modified by pressing the ✓ button to select the item and the ▲ and ▼ buttons to define them.

Item	Values
Schedule Entry	1-16
Start Time	00:00-23:59
Duration	00:00-99:59
Day	Monday-Sunday
Week (of month)	First, Second, Third, Fourth

Note: The controller must be in Auto mode to run at the programmed time. Use a trickle or solar battery charger to prevent the controller from draining the battery while in Auto mode.

Set the Unit To Auto Mode

1. From any operator or maintenance screen, press and hold the Auto/Manual Mode  button for five seconds, or until Auto mode is displayed at the top of the screen.

Note: If any of the scheduled time slots are currently active, the controller will begin the starting sequence and start the unit provided there are no shutdown conditions present.

SHUTTING DOWN THE UNIT

Check with personnel using power supplied by the generator and let them know that the power is going to be turned off. Verify the power shut down will not create any hazards by accidentally turning off equipment that needs to be kept on (pumps, compressors, lights, etc.).

1. Remove all loads from the generator by opening all circuit breakers (turn OFF (O)).
2. Let the engine run for approximately five minutes to allow it to cool down.
3. Push O. Pressing the red Engine Stop/Reset (O) button will result in the generator going into the shutdown cycle and starting a 15 second shutdown timer called stopping. If the unit does not shut down within 15 seconds, a stop fail alarm will be displayed on the LCD window.
4. After the unit shuts down, move the Control Power switch to OFF (O).

Note: For extended storage time, disconnect the battery. Refer to the engine operator’s manual for extended storage requirements.

EMERGENCY STOP SWITCH

The unit is equipped with one emergency stop switch. For location of the emergency stop switch, see **Component Locations**. The switch can be accessed and activated with all doors closed and locked.

Activate the emergency stop switch by pushing the button in until it locks down. This will trip the main circuit breaker which will open the contact, disconnecting the load to the connection lugs. This will also open the fuel circuit, shutting down the engine. The emergency stop fault will be displayed on the control panel. The switch will remain locked until it is pulled out.

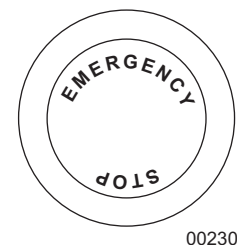

Figure 3-11. Emergency Stop Switch

NOTICE

Use the emergency stop switch only when the unit must be shut down immediately. For any other shut down, see *Shutting Down the Unit*.

TOWING THE UNIT

1. Use the jack to raise or lower the trailer onto the hitch of the towing vehicle. Lock the hitch coupling and attach the safety chains or cables to the vehicle. Raise the jack foot completely.
2. Connect any trailer wiring to the tow vehicle. Check for proper operation of the directional and brake lights.
3. Verify all doors are properly latched.
4. Check for proper inflation of the trailer tires. For maximum tire pressures, see *Specifications*.
5. Check the wheel lugs. Tighten or replace any that are loose or missing. If a tire has been removed for axle service or replaced, tighten the lugs in the order shown to the following specifications:
 - A. Start all lug nuts by hand.
 - B. First pass tighten to 20-25 ft-lbs (27-33 Nm).
 - C. Second pass tighten to 50-60 ft-lbs (67-81 Nm).
 - D. Third pass tighten to 90-120 ft-lbs (122-162 Nm).

Note: After the first road use, re-torque the lug nuts in sequence.

6. Maximum recommended speed for highway towing is 45 mph (72 km/h). Recommended off-road towing speed is not to exceed 10 mph (16 km/h).

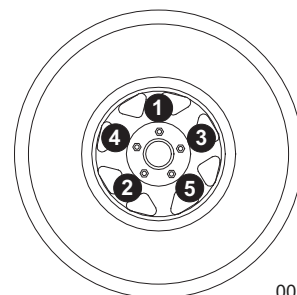

00204

Figure 3-12. Lug Sequence

LIFTING THE UNIT

A central lift point is located on the top of the unit. The central lift point is connected to a lift structure inside the unit. Attach a sling or hook directly to the central lift point only if the devices are in good condition and the equipment being used to raise the unit has sufficient capacity. For approximate weights, see *Specifications*. Always remain aware of others around you when moving or lifting the unit. Keep the doors closed and locked.

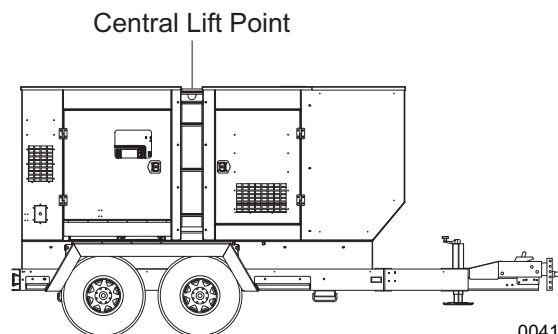

00419

Figure 3-13. Lift Point

This Page Intentionally Left Blank

Section 4 - Maintenance

EMISSIONS INFORMATION

For emissions information, see the engine OEM manual.

DAILY WALK AROUND INSPECTION

Look for conditions that could hinder performance or safety, such as (but not limited to) oil/coolant/fuel leakage, blocked vents, loose/missing hardware, and electrical connections.

Visually inspect the fan belt for cracks, fraying, stretching, and verify the belt is properly seated in the pulley grooves. Replace the belt according to the manufacturer's recommendations.

Note: *At the 500 hour/12 month service interval, it is recommended that the belt be removed and checked for wear. While the belt is removed, inspect pulleys and bearings. Rotate and feel for hard turning or unusual sounds. If pulleys or bearings need replacement, contact the engine manufacturer.*

NOTICE

Failure to perform a daily inspection may result in serious damage to the prime mover.

GENERAL MAINTENANCE

Normal maintenance service and replacement of parts are the responsibility of the owner and are not considered defects in materials or workmanship within the terms of the warranty. It is strongly recommended that the equipment be periodically checked by a Generac Mobile Products Authorized Dealer.

Poorly maintained equipment can become a safety hazard. In order for the equipment to operate safely and properly over a long period of time, periodic maintenance and occasional repairs are necessary. **DO NOT** perform routine service (oil/filter changes, cleaning, etc.) unless all electrical components are shut off. Before servicing the unit, always follow the instructions listed below.

- Verify the Control Power switch is OFF (O).
- Verify the circuit breakers are OFF (O).
- Activate (push in) the emergency stop switch.
- Disconnect the negative (-) terminal on the battery.
- Attach a "Do Not Start" sign to the control panel. This will notify everyone that the unit is being serviced and will reduce the chance of someone inadvertently trying to start the unit.
- Do not wash the unit with a high pressure hose or with any kind of power washer.
- Do not wash the engine block or fuel tank with a power washer or steam cleaner. Water may enter the cabinet and collect in the generator windings or other electrical parts, causing damage.
- If the unit is stored outside, check for water inside the cabinet and generator before each use. If wet, dry the unit thoroughly before starting.
- Inspect condition of electrical cords. **DO NOT** use the unit if insulation is cut or worn through.
- Check wheel lugs. See [Towing The Unit](#).
- Check coolant level daily. Refer to the engine operator's manual for coolant recommendations and proper mixture.
 - Coolant is checked visually by inspecting the level in coolant overflow jug located near the radiator.
 - Normal operating level is between the full and add markings on the overflow jug known as normal range.
 - **WHEN ENGINE IS STOPPED AND COMPLETELY COOL**, coolant may be added directly to the coolant overflow jug.

Maintenance

- Check oil level daily. See the engine operator's manual for the proper viscosity grade of oil, including special operating conditions such as a change in season or climate.
 - **DO NOT** start the unit if the engine oil level is below the add mark on the dipstick.
 - Normal operating level is in the cross-hatch pattern between the full and add markings on the dipstick.
 - Add oil only if the oil level is below the add mark on the bottom of the cross-hatch pattern on the dipstick. **DO NOT OVERFILL** the crankcase.
- Check fuel level.
- If the unit is connected to a remote start or transfer switch, make sure the remote switch is also off and tagged.

Note: If the engine was run out of fuel or the fuel tank was drained, it may be necessary to bleed the fuel lines. Refer to the engine operator's manual supplied with the unit.

BASIC MAINTENANCE SCHEDULE - JOHN DEERE ENGINE

NOTICE

Refer to the original equipment manufacturer's operating manual for a complete list of maintenance requirements. Failure to comply with the procedures as described in the engine operator manual will nullify the warranty, decrease performance and cause equipment damage or premature equipment failure. Maintenance records may be required to complete a warranty request.

Use the schedule in the following table as a guide for regular maintenance intervals. For additional or replacement copies of the engine operator's manual, contact an authorized dealer in your area.

Item	Daily	250 Hrs.	500 Hrs./12 Months	3000 Hrs./ 36 Months	As Required
Check Oil Level	◆				
Check Coolant Level	◆				
Check Fuel Level	◆				
Check Tire Pressure	◆				
Check All Electrical Connections	◆				
Inspect Radiator Fins For Debris, Clean As Required	◆				
Check Fuel Filter/Water Separator Bowl	◆				
Check Air Cleaner Dust Valve Restriction Indicator Gauge	◆*				
Perform Visual Walkaround Inspection	◆				
Check Oil Vapor Recirculation System/Non-Return Valve		◆			
Change Engine Oil and Replace Oil Filter			◆**		
Replace Oil Vapor Recirculation Filter			◆		
Service Battery			◆		
Replace Fuel Filter Elements			◆		
Check Engine Mounts			◆		
Check Air Intake Hoses, Connections, and System			◆		
Check Engine Electrical Ground Connection			◆		
Check Automatic Belt Tensioner and Belt Wear			◆		
Check Cooling System			◆		
Lubricate Leveling Jack(s)			◆		
Check Generator Drive Plate Torque (refer to <i>Checking Generator Drive Plate Torque</i>)			◆		
Test Thermostats				◆	

Item	Daily	250 Hrs.	500 Hrs./12 Months	3000 Hrs./ 36 Months	As Required
Replace Air Cleaner Elements					◆
Replace Alternator and Fan Belts					◆
Check Fuses					◆
Add Coolant					◆
Check Electrical Wiring and Connections					◆

* Replace primary air cleaner when dust valve restriction indicator gauge shows a vacuum of 25 in. H₂O.

** Change the oil and oil filter after the first 100 hours, then every 500 hours. If not using John Deere Plus 50 II engine oil, the interval must be decreased to every 250 hours.

ENGINE BREAK-IN REQUIREMENTS

Note: During the first 20 hours of operation, avoid long periods of no load or sustained maximum load operation. If the generator is to run for longer than five minutes without a load, shut the generator down.

John Deere engines are supplied with engine break-in oil from the factory. Extra care during the first 100 hours of engine operation will result in better performance and longer engine life. **DO NOT** exceed 100 hours of operation with the break-in oil. Operate the engine at heavy loads (60-90% of maximum) as much as possible. If the engine has spent significant time at idle, constant speed(s), and/or light load, or if makeup oil is required, a longer break in period may be needed. Refer to the engine operator's manual for a full description of necessary procedures on the addition of break-in oil and extension of the break-in period. For more information on regular maintenance intervals, refer to [Basic Maintenance Schedule - John Deere Engine](#).

RESETTING THE MAINTENANCE ALARMS

The Power Zone™ controller will display a warning message when the unit is due for maintenance or service. The maintenance or service interval is set at 250, 500 and 3000 hours of engine running time. Once the unit has been serviced, the appropriate maintenance alarm reminder needs to be reset. The following procedure demonstrates how to reset the maintenance alarms:

1. With the unit shut down, move the control power switch to ON (I). After initialization, the controller will toggle automatically to the Home screen.
2. Press any directional arrow (▲, ►, ▼, ◀) to enter the maintenance screens.
3. Press the Enter (✓) button and the Engine Stop/Reset (O) button simultaneously. The next screen will display the Configuration menu.
4. Press ▼ to move the cursor (blue highlighted text) down to the "Maintenance" group.
5. Press ► to access the sections. Press ▼ to highlight the "Maintenance" section.
6. Press ► to access the parameters and highlight the maintenance alarm that needs to be reset.
7. Press the Enter (✓) button to select the editable parameters. The cursor will highlight "Not Reset" under the selected maintenance alarm. Press ▲ to highlight "Reset".
8. Press the Enter (✓) button to reset the selected maintenance alarm.
9. To perform additional maintenance alarm resets, repeat steps 6 - 8.

Note: If the selected maintenance alarm does not need to be reset, press the ▼ button to highlight "Not Reset" and press the Enter (✓) button return to the parameters section.

10. To save changes, press and hold the Enter (✓) button for five seconds. To discard changes made, press and hold the Engine Stop/Reset (O) button for five seconds.

EXHAUST FILTER SERVICE REQUIREMENTS (FOR PZ UNITS WITH DPF ONLY)

The exhaust filter system contains a Diesel Particulate Filter (DPF). Over time, the DPF will require professional servicing to remove ash buildup. The expected service interval will be at least 3,000 or 4,500 hours, based on engine power and operating conditions. Actual service should take place when the indicator light appears on the Power Zone™ controller. The DPF should be cleaned or replaced by an authorized service provider only. The removal of DPF ash must be done by removing the DPF from the unit and placing it into specialized equipment.

▲ CAUTION

Do not remove ash by using water or other chemicals. Removing ash by these methods may cause equipment damage and create unsafe operating conditions.

▲ CAUTION

Only a qualified service provider should remove, handle and dispose of DPF ash. These materials may be considered hazardous under federal, state and local regulations, and must be handled and disposed of properly.

To avoid unnecessary buildup of diesel particulates or soot in the exhaust filter system:

1. Utilize the Automatic Exhaust Filter Cleaning mode.
2. Avoid unnecessary idling.
3. Use proper engine oil. Refer to the engine operator's manual.
4. Use only ultra low sulfur diesel fuel. Refer to the OEM engine operator's manual.

CHECKING GENERATOR DRIVE PLATE TORQUE

Follow the procedure below to check the torque of the generator drive plate bolts in accordance with the maintenance chart. Refer to [Basic Maintenance Schedule - John Deere Engine](#).

1. Disconnect engine starting battery.
2. Remove generator fan guard.
3. Tighten each of the drive plate bolts to the appropriate specification shown in the table below.

Unit	ft-lbs (Nm)
MMG130DI4	36 (49)
MMG175DI4	46 (63)
MMG205DI4	47 (64)

4. Reinstall generator fan guard.
5. Reconnect battery.

JACK MAINTENANCE

The following procedures should be performed at least annually.

Side-Wind Models

- The internal gearing and bushings of the jack must be kept lubricated. Apply a small amount of automotive grease to the internal gearing by removing the jack cover, or if equipped, use a needle nose applicator or

standard grease gun on the lubrication point found on the side of the jack near the crank. Rotate the jack handle to distribute the grease evenly.

- A lightweight oil must be applied to the handle unit at both sides of the tube.
- If equipped, the axle bolt and nut assembly of the caster wheel must also be lubricated with the same lightweight oil.

Top-Wind Models

- Apply a lightweight oil to the screw stem.

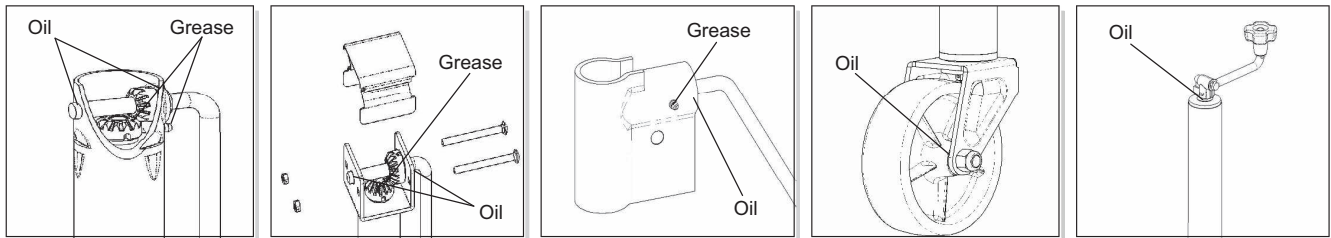

00243

Figure 4-1. Apply Oil

TRAILER WHEEL BEARINGS

The trailer axles are equipped with a grease fitting to allow lubrication of the wheel bearings without the need to disassemble the axle hub. To lubricate the axle bearings, remove the small rubber plug on the grease cap, attach a standard grease gun fitting to the grease fitting and pump grease into the fitting until new grease is visible around the nozzle of the grease gun. Use only a high quality grease made specifically for lubrication of wheel bearings. Wipe any excess grease from the hub with a clean cloth and replace the rubber plug when finished. The minimum recommended lubrication is every 12 months or 12,000 miles (19,312 km). More frequent lubrication may be required under extremely dusty or damp operating conditions.

This Page Intentionally Left Blank

Section 5 - Troubleshooting

GENERAL TROUBLESHOOTING

Some of the more common problems are listed in the table below. This information is intended to be a check or verification that simple causes can be located and fixed. It does not cover all types of problems. Refer to the OEM engine operator's manual for additional troubleshooting information. Procedures that require in-depth knowledge or skills should be referred to a trained technician.

Table 1 - General Troubleshooting Guide

Problem	Possible Cause	Solution
Low Fuel Level Shut-down	Low fuel level	Check fuel level in LCD window of controller.
	Unit not level	Verify unit is sitting level to ensure an accurate reading.
	Fuel tank leaking	Check tank for leaks.
	Damaged fuel sender or wiring	Check for continuity between sender and engine controller. (Refer to DC wiring diagram.)
Low Oil Pressure Shutdown	Low oil level	Check oil level on dipstick. Add oil, if needed.
	Oil leaking from engine	Visually inspect the engine for leaks. Restart unit and verify loss of pressure. Shut down immediately if pressure does not reach 5 psi (34 kPa) within five seconds.
	Oil pressure sender	See the OEM engine operator's manual to identify corrective action.
Low Coolant Level Shutdown	Low coolant level	Allow engine to cool, then check coolant level in radiator. Add coolant if needed.
	Coolant hoses leaking	Inspect hoses for leaks. Repair or replace as necessary.
	Engine block or water pump leaking	Visually inspect for leaks. Verify no coolant has mixed with the engine oil (oil will appear milky). See the OEM engine operator's manual for additional information.
High Coolant Temperature Shutdown	Low coolant level	Add coolant if needed. Allow engine to cool, then check coolant level in radiator. Restart engine and check coolant temperature (on controller). Stop engine immediately if coolant temperature is 210°F (99°C) or more.
	Blockage in radiator	Check radiator shroud and ducting for blockage and remove any foreign matter.
	Leakage in coolant hoses, engine block, or water pump	Inspect for visible leaks. Check tension of water pump serpentine drive belt. Remove load on generator and restart engine. Check coolant temperature and shut engine down immediately if it starts to overheat. See the OEM engine operator's manual for additional information on engine overheating.

Table 1 - General Troubleshooting Guide

Problem	Possible Cause	Solution
Overcrank Shutdown	Fuel level low	Check fuel level in tank. Check fuel pump operation. Check air filter for blockage. See the OEM engine operator's manual for additional information.
Overspeed or Under-speed Shutdown	Frequency setting incorrect	Disconnect all loads and restart unit. Read frequency (Hz) in the LCD window on controller. Frequency should read 60 Hz. If frequency is above 60 Hz, engine speed will need to be adjusted. Contact Generac Mobile Products to adjust voltage.

Section 6 - Wiring Diagrams

AC WIRING - 3 POSITION VOLTAGE SELECTOR SWITCH - MMG130DI4

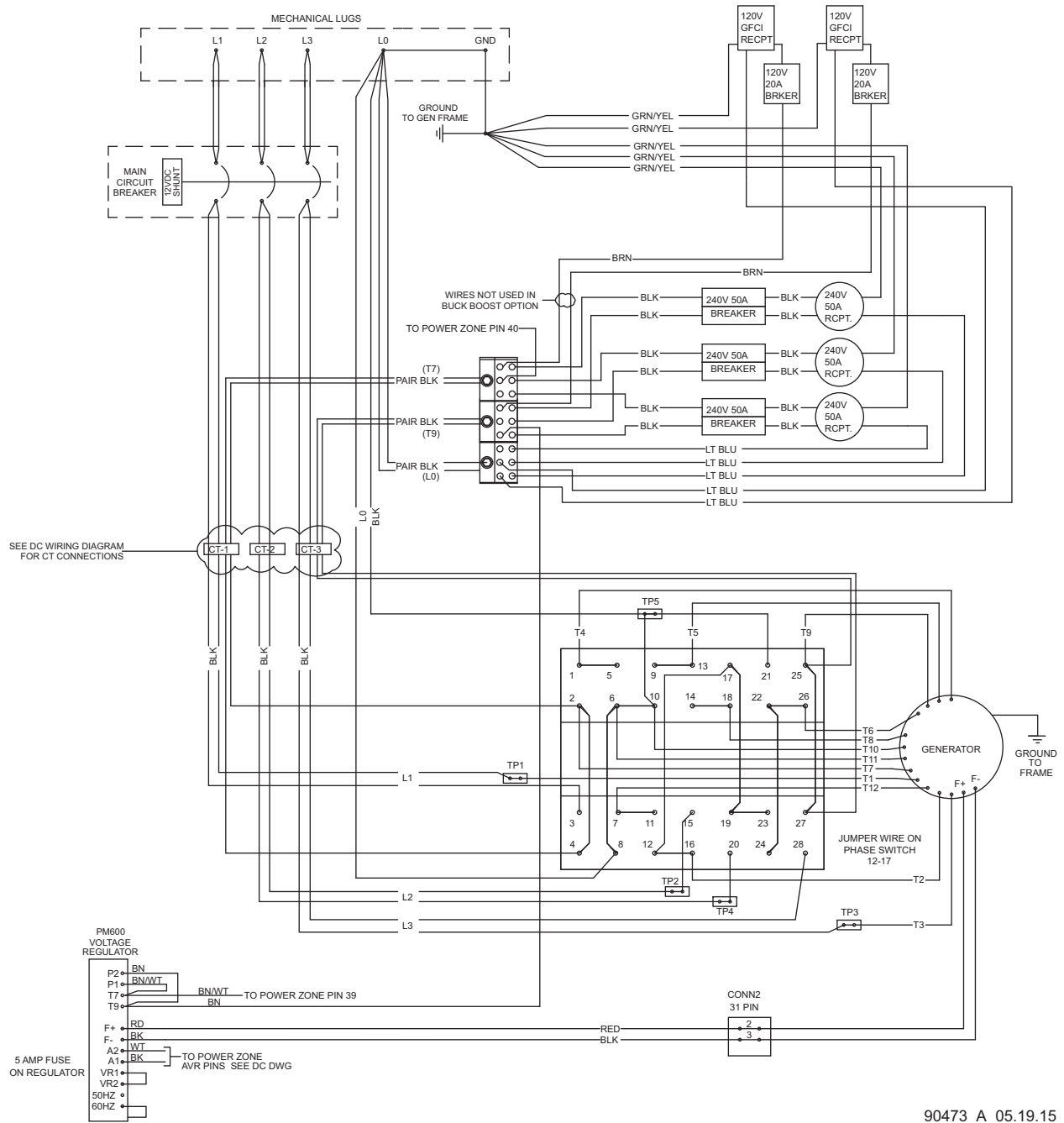

AC WIRING - 3 POSITION VOLTAGE SELECTOR SWITCH - MMG175DI4

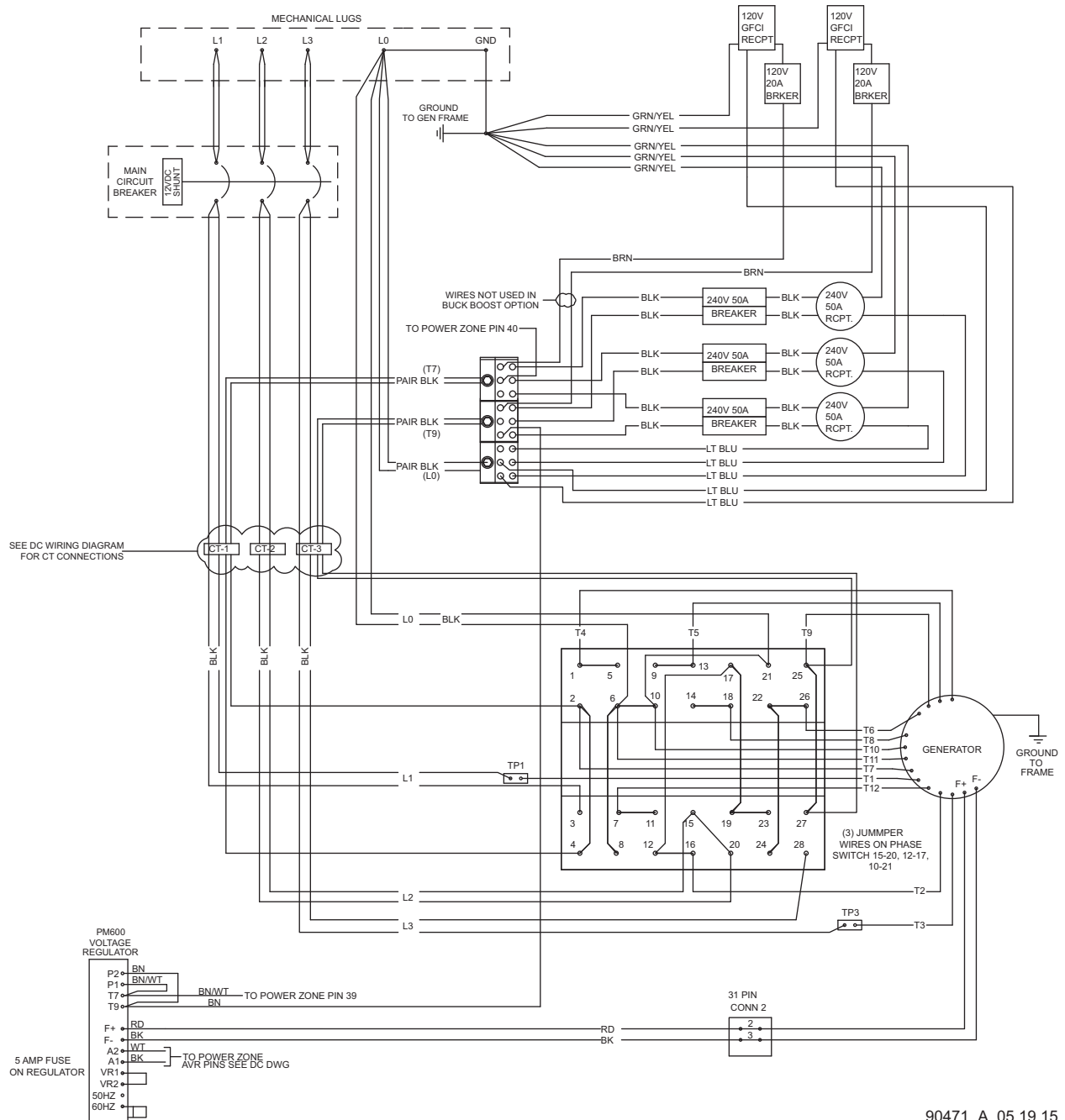

90471_A_05.19.15

AC WIRING - 3 POSITION VOLTAGE SELECTOR SWITCH - MMG205DI4

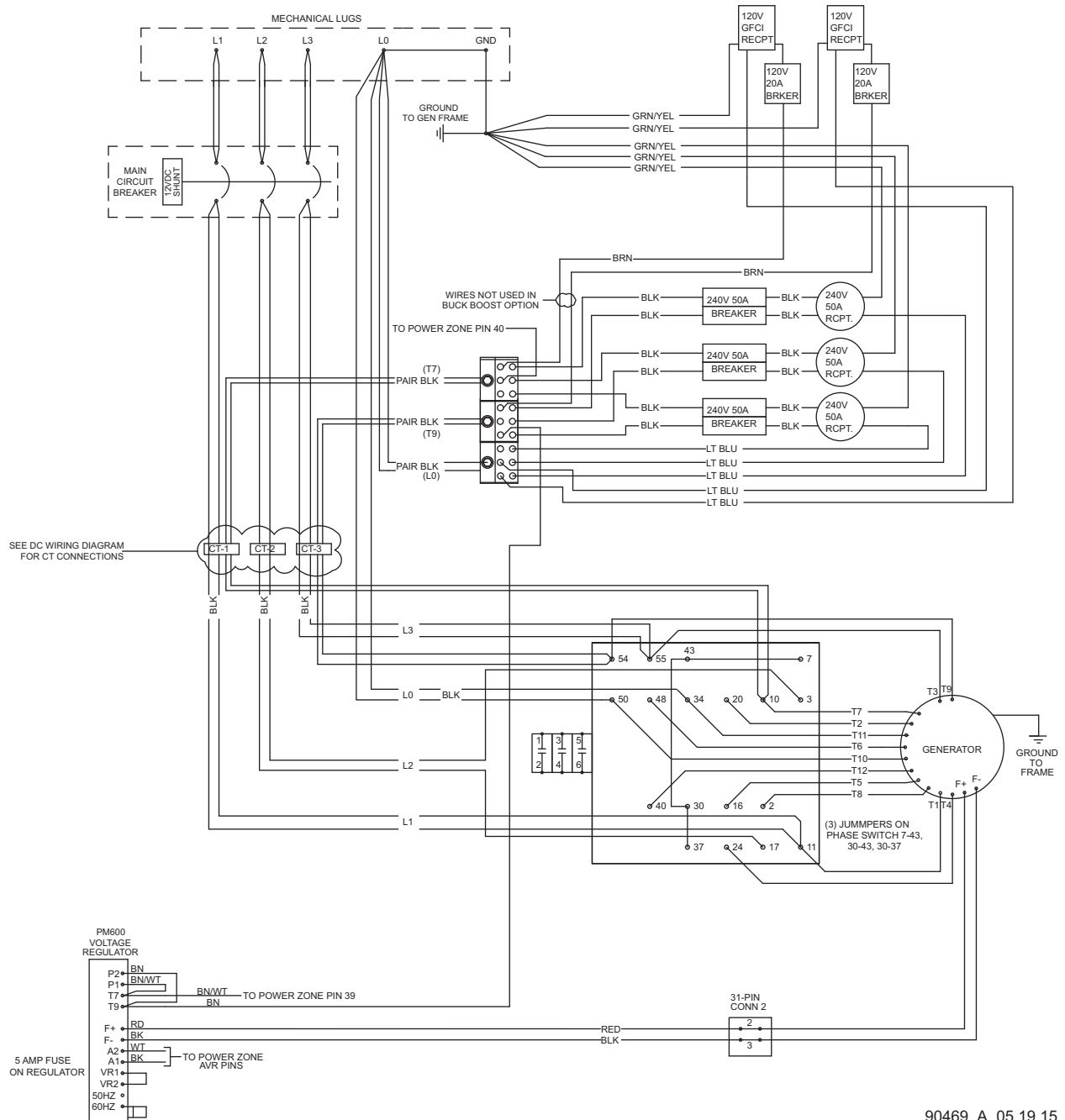

90469_A_05.19.15

AC WIRING - 4 POSITION VOLTAGE SELECTOR SWITCH OPTION - MMG130DI4, MMG175DI4

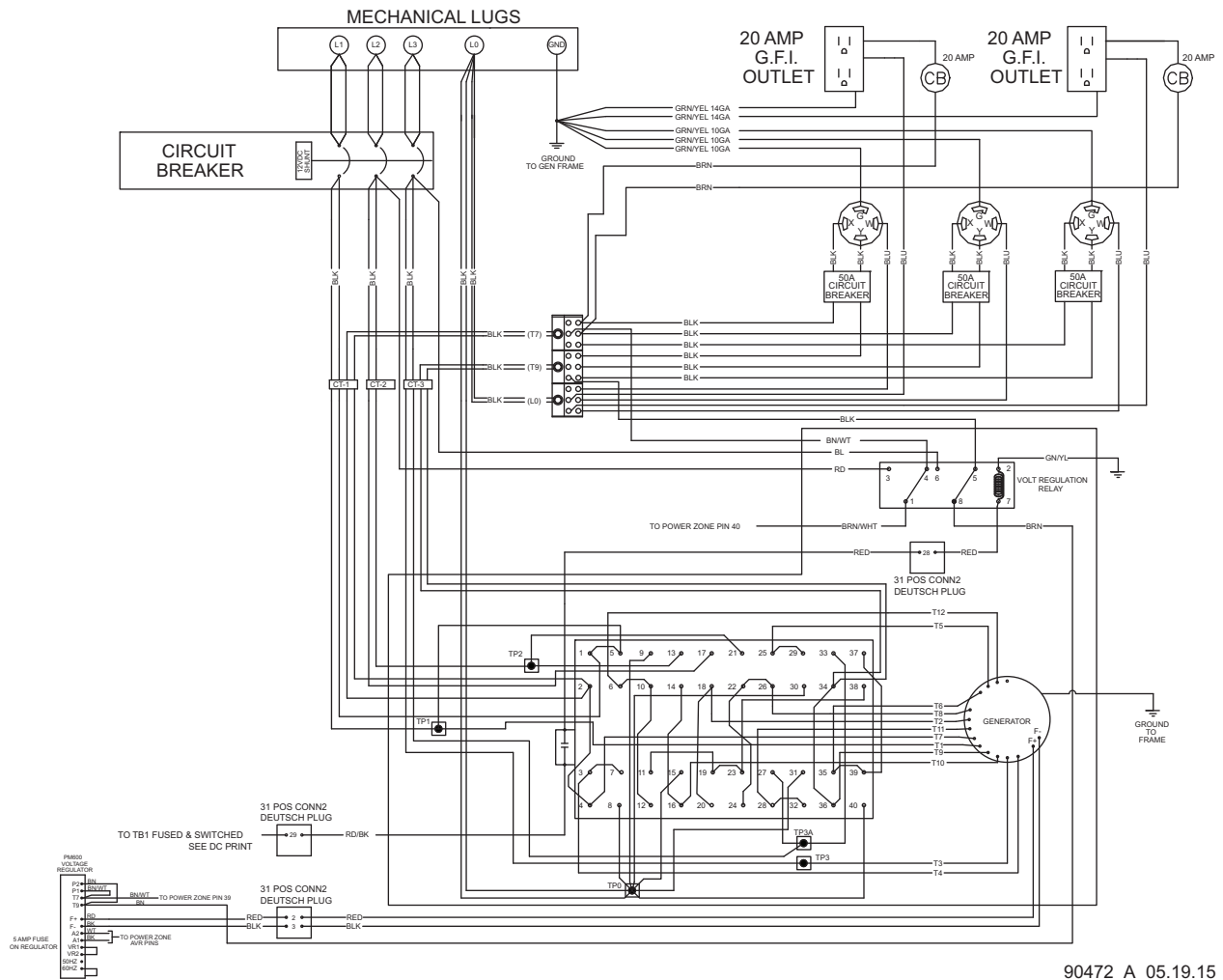

90472_A_05.19.15

AC WIRING - 4 POSITION VOLTAGE SELECTOR SWITCH OPTION - MMG205DI4

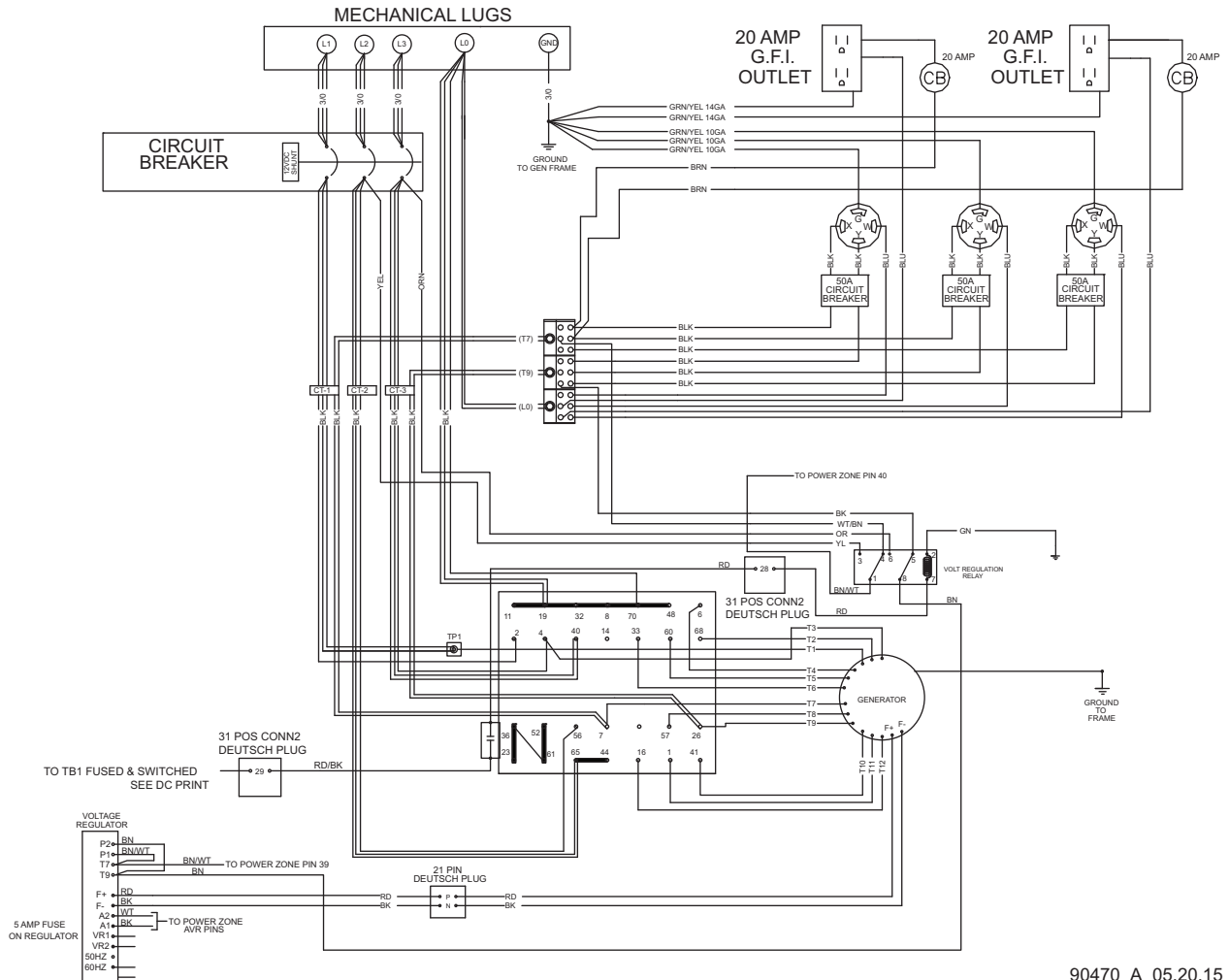

90470_A_05.20.15

DC WIRING

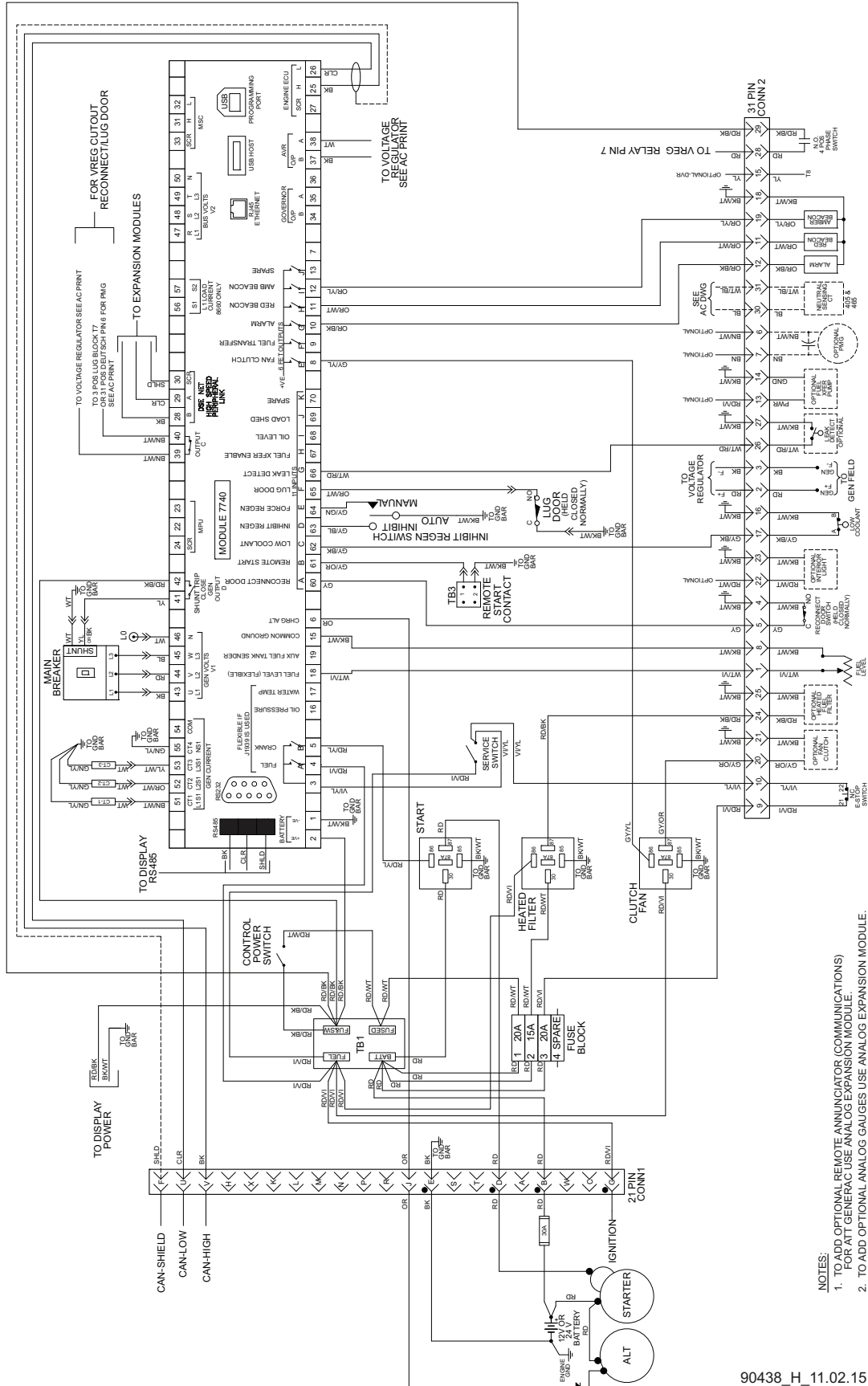

- NOTES:
1. TO ADD OPTIONAL REMOTE ANNUNCIATOR (COMMUNICATIONS) FOR AT GENERAC USE ANALOG EXPANSION MODULE.
 2. TO ADD OPTIONAL ANALOG GAUGES USE ANALOG EXPANSION MODULE.

90438_H_11.02.15

DC WIRING OPTIONS

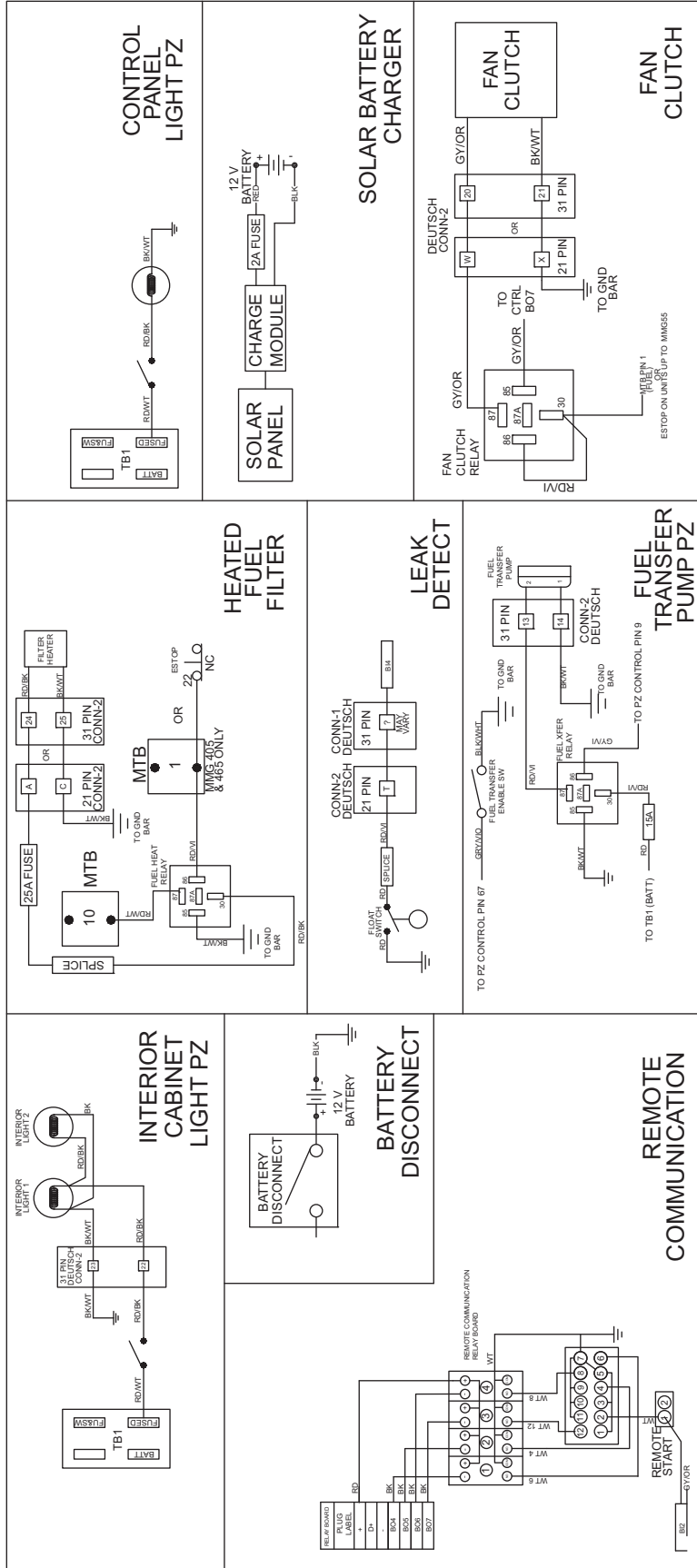

90416_N_11.20.14

WIRING BLOCK DIAGRAM - DEDICATED 12 LEAD GENERATORS OPTION

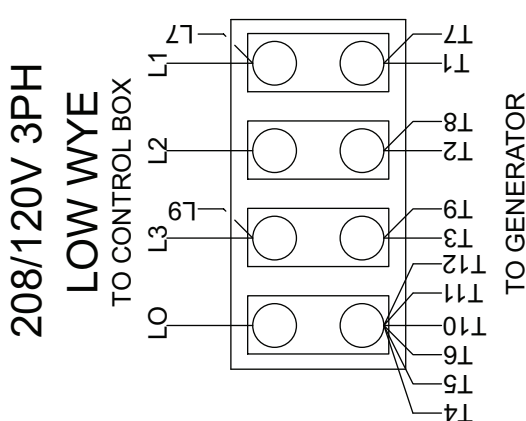
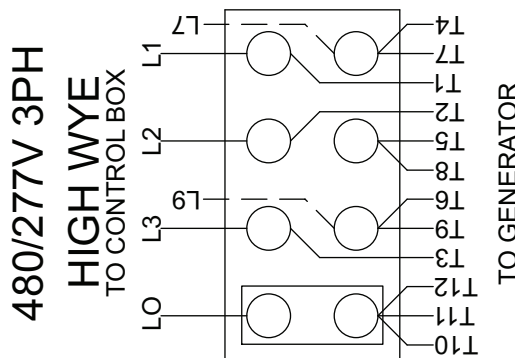
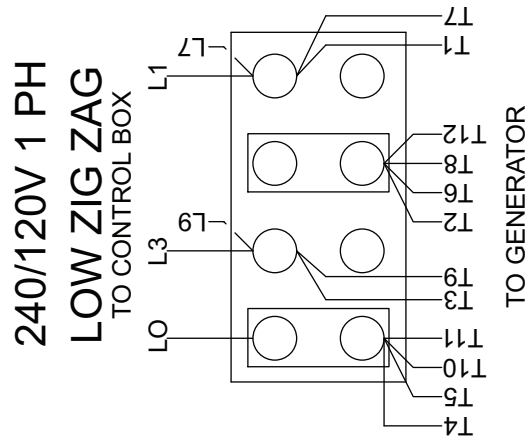
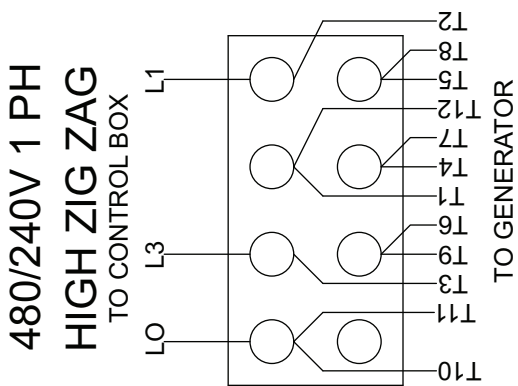
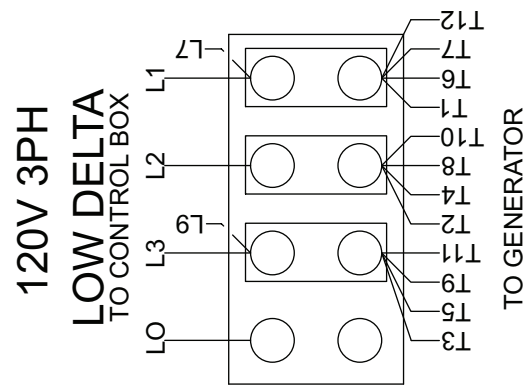
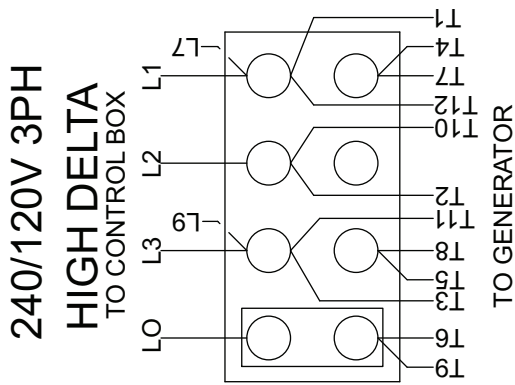

NOTE:
 1. CABLES TO CONTROL BOX MAY CONTAIN 1, 2 OR 3 WIRES DEPENDING ON THE MODEL AND VOLTAGE.
 2. APPLIES TO ALL 12 LEAD GENERATORS TO BE HARD WIRED IN GEN BOX.

90302_A_11.06.12

TRAILER LIGHTS WIRING

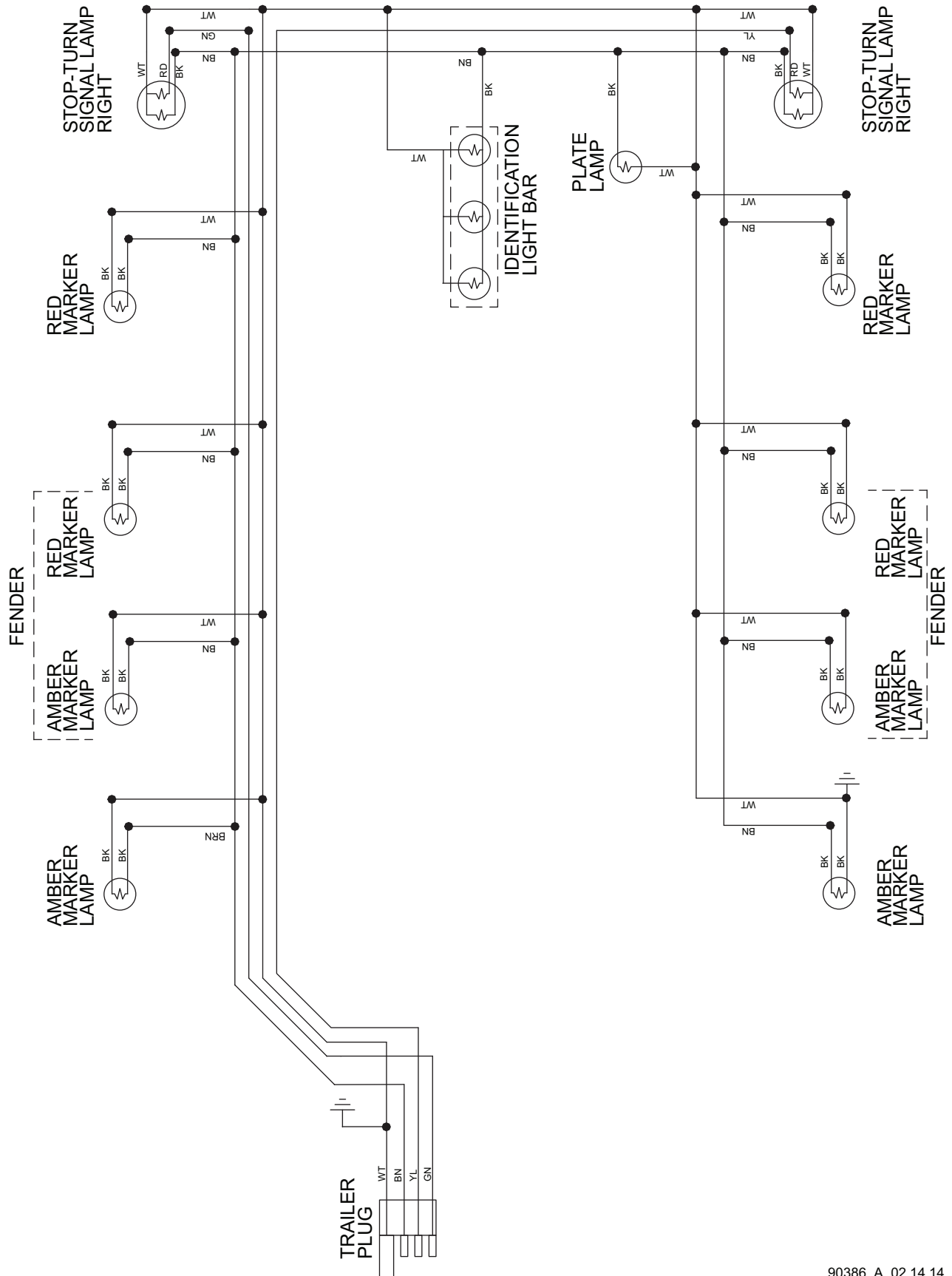

90386_A_02.14.14

WIRING HARNESS - ELECTRIC BRAKE OPTION

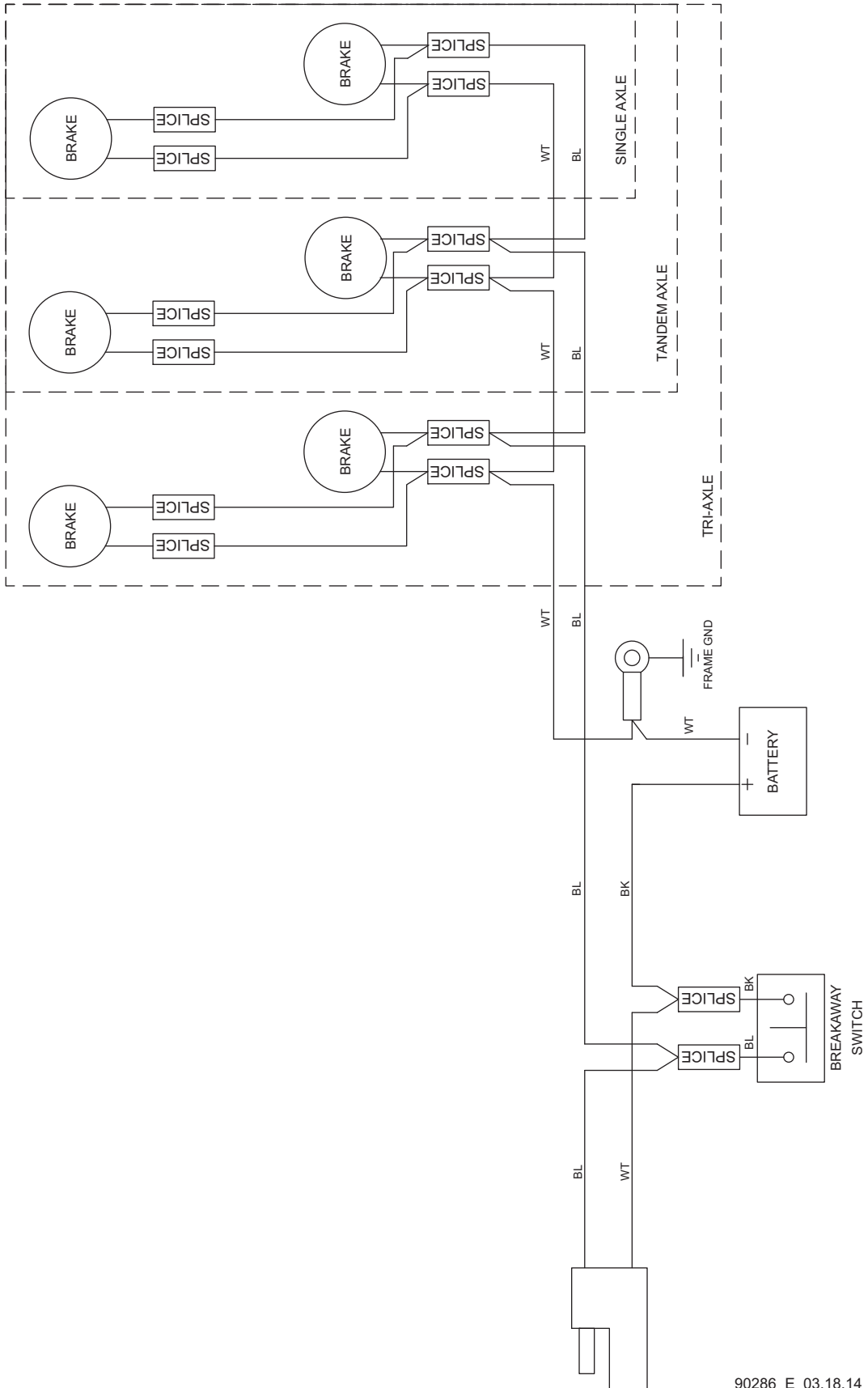

90286_E_03.18.14

This Page Intentionally Left Blank

Section 7 - Options & Accessories

GENERATOR CAM LOCK CONNECTIONS OPTION

The unit may be equipped with cam lock connections, located below the receptacles. These receptacles provide connection points for the attachment of external loads to the generator. A large decal on the inside of the connection lug door details the proper connections for selected voltages.

⚠ WARNING

It is **HIGHLY RECOMMENDED** that only a trained and licensed electrician perform any wiring and related connections to the generator. Installation should be in compliance with the National Electrical Code (NEC), state and local regulations. Failure to follow proper installation requirements may result in equipment or property damage, personal injury or death.

⚠ WARNING

Before any connections are made to the generator, make sure that the main circuit breaker and the Control Power switch are OFF (O) and that the negative (-) battery cable is disconnected. Potentially lethal voltages may be present at the generator connection lugs.

⚠ DANGER

IMPROPER OR INCORRECT CONNECTIONS TO A BUILDING'S ELECTRICAL SYSTEM CAN CAUSE POTENTIALLY LETHAL VOLTAGE TO BACKFEED INTO UTILITY LINES. THIS MAY RESULT IN INJURY OR ELECTROCUTION TO UTILITY WORKERS NEARBY. MAKE SURE THE GENERATOR IS SUPPLYING POWER TO AN ISOLATED OBJECT OR BUILDING THAT IS NOT CONNECTED TO ANY UTILITY LINES.

Connections should be made by plugging power cables equipped with series 16 taper nose 400A/600V cam lock plugs into the cam lock receptacles. Secure the connection by rotating the plug a 1/2 turn to the right. The lug door is equipped with safety interlock switches that will trip the main circuit breaker and disable the voltage regulator, dropping the generator output to residual voltage, if the door is opened while the unit is operating.

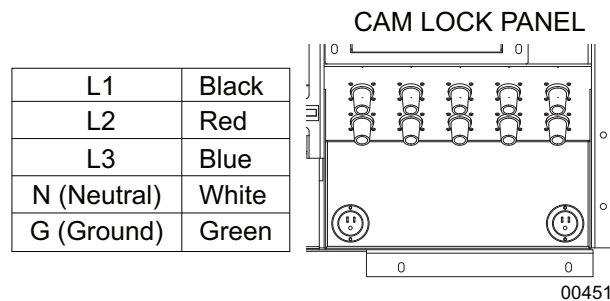

Figure 7-1. Cam Lock Connections

⚠ WARNING

DO NOT attempt to disable or modify the lug door safety switches. Equipment damage, personal injury or death may result.

A ground connection is located on the far right of the cam lock panel. The unit **MUST** be connected to a good earthen ground for proper operating safety. The generator neutral is bonded to ground when it is shipped from the factory. The bonding plate will need to be removed when the generator is used as a standby power source. **INSTALLATION SHOULD BE IN COMPLIANCE WITH THE NATIONAL ELECTRICAL CODE (NEC), STATE AND LOCAL REGULATIONS.**

VISCOUS FAN CLUTCH OPTION

The viscous fan clutch option allows the engine cooling fan to engage at lower speeds and disengage at higher speeds, increasing cooling system efficiency. The cooling fan will engage at full speed when the coolant temperature rises. When the fan is operating at full speed, it will switch to a slower speed when the coolant temperature drops. There will be an audible difference when the engine cooling fan switches speeds. Depending on unit model, the temperature ranges vary between 170°F and 200°F (77°C and 93°C).

