

Owner's Manual

Light Tower

MLT4060MVD

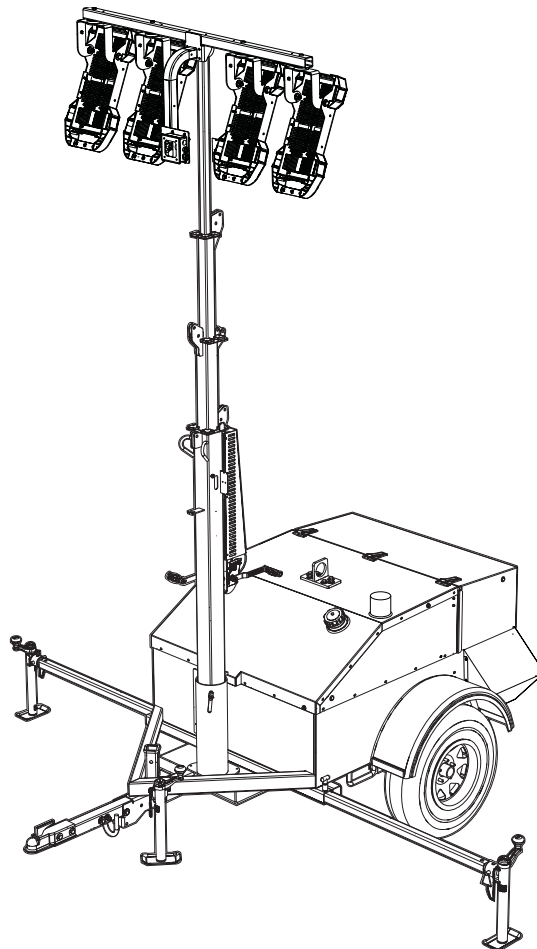

For technical assistance contact:

www.generacmobileproducts.com

Technical Support

1-800-926-9768

SAVE THIS MANUAL FOR FUTURE REFERENCE

Use this page to record important information about your Light Tower

Unit Model Number	
Unit Serial Number	
Engine Model Number	
Engine Serial Number	
Generator Model Number	
Generator Serial Number	

Record the information found on your unit data label on this page. See unit serial number location (***Unit Serial Number Locations***). The label plate is affixed to the inside partition, to the left of the control panel console.

Engine and generator serial numbers are located on separate data plates affixed to the engine and generator respectively.

When contacting a Generac Mobile Products Authorized Service Dealer (ASD) about parts and service, always supply the complete model number and serial number of the unit.

Operation and Maintenance: Proper maintenance and care of the Light Tower ensures a minimum number of problems and keeps operating expenses at a minimum. It is the operator's responsibility to perform all safety checks, to verify that all maintenance for safe operation is performed promptly, and to have the equipment checked periodically by an ASD. Normal maintenance, service and replacement of parts are the responsibility of the owner/operator and, as such, are not considered defects in materials or workmanship within the terms of the warranty. Individual operating habits and usage may contribute to the need for additional maintenance or service.

! WARNING

California Proposition 65. Engine exhaust and some of its constituents are known to the state of California to cause cancer, birth defects, and other reproductive harm. (000004)

! WARNING

California Proposition 65. This product contains or emits chemicals known to the state of California to cause cancer, birth defects, and other reproductive harm. (000005)

Table of Contents

Section 1: Safety Rules & General Information

Introduction	1
Read This Manual Thoroughly	1
How to Obtain Service	1
Safety Rules	1
Safety Symbols and Meanings	2
General Hazards	2
Explosion and Fire Hazards	3
Trailer Hazards	3
Electrical Hazards	3
Battery Hazards	4
Fuel Hazards	4
Engine Safety	4
Operating Safety	5
Positioning the Unit	5
Starting the Unit	5
Towing Safety	5
Hitch and Coupling	5
Running Lights	5
Wheels and Tires	5
Safe Towing Techniques	5
Tandem Towing Safety	5
Reporting Trailer Safety Defects	6
Safety and Operating Decals	6

Section 2: General Information

Specifications	11
Unit Dimensions	12
Unit Serial Number Locations	13
Component Locations	14
Control Panel	15
Control Panel Features and Functions	15
Keep Run Ambient Sensor (if equipped)	16
ECOSpeed™ Engine	16
Positive Air Shutdown (PAS) (if equipped)	16
Test the PAS	16
Reset the PAS	17
Lower Radiator Hose Heater (if equipped)	17
Use and Maintenance	17

Diesel Fired Block Heater (if equipped)	17
Heated Fuel Filter (if equipped)	18
Battery Disconnect (if equipped)	18
Telemetry (if equipped)	18
Spark Arrester (if equipped)	18
Power Zone—DLA	18
Controller Features and Functions	19
Operator Screens	19

Section 3: Operation

Light Tower Setup	25
Fuel Recommendations	26
Engine Oil Recommendations	26
Coolant Recommendations	26
Standard Units	26
Cold Climate / Arctic Package Units	26
Prestart Checklist	26
Raising the Mast—Manual Winch	27
Raising the Mast—Electric Winch (if equipped)	28
Preparing for Start-Up	29
Select AUTO Mode or MANUAL Mode	29
Configure for Intended Use	29
Start Sequences	29
Start Sequence—Standard Units	30
Start Sequence—Units with Diesel Fired Block Heaters	31
Manually Starting the Unit In Low Speed	32
Manually Starting the Unit In High Speed	32
Light Operation	32
Engine Derating	32
Wet Stacking	33
Dusk to Dawn Sensor	33
Fuel Level Warning Beacon	33
Customer Convenience Outlets	33
Shutting Down the Unit	33
Automatic Shutdown	34
Emergency Stop	34

Lowering the Mast—Manual Winch	34
Lowering the Mast—Electric Winch (if equipped)	35
Electrically Lowering the Mast	35
Manually Lowering the Mast	35
Towing the Unit	35
Tandem Tow	36
Tying the Unit Down	36
Lifting the Unit	36

Section 4: Maintenance

Emissions Information	37
Daily Walk-Around Inspection	37
General Maintenance	37
Preparing for Service	37
Cleaning the Unit	37
Inspecting the Unit	37
Resetting the Maintenance Alarms	39
Winch Use, Operation and Maintenance—Manual	39
Prior to Use	39
Operation	39
Maintenance	39
Winch Use, Operation and Maintenance—Electric	40
Winch Mechanical Brake	40
Jack Maintenance	41
Trailer Wheel Bearings	41

Section 5: General Troubleshooting

Section 6: Electrical Drawings

Wiring Diagrams	45
Legend / Components Located on Engine	45
Components Located on Engine (p. 2)	46
Components Located on Engine (p. 3)	47
Components Located on Engine (p. 4)	48
Accessories (Optional)	49
Accessories (Optional) (p. 2)	50
DC Components in Control Panel	51
AC Components in Control Panel	52
AC Components in Control Panel and Alternator Box	53
Components Located in Mast Box	54
Schematic Diagrams	55
Components Located in Mast Box	55
Components Located in LED Box	56
Engine Control Module Connections	57
A/C Schematic	58
Relays (p. 1)	59
Relays (p. 2)	60
Relays (p. 3)	61
DC Connections (p. 1)	62
DC Connections (p. 2)	63

Section 1: Safety Rules & General Information

Introduction

Thank you for purchasing a Generac Mobile Products LLC product. This unit has been designed to provide high performance, efficient operation, and years of use when maintained properly.

The information in this manual is accurate based on products produced at the time of publication. The manufacturer reserves the right to make technical updates, corrections, and product revisions at any time without notice.

Read This Manual Thoroughly



Consult Manual. Read and understand manual completely before using product. Failure to completely understand manual and product could result in death or serious injury. (000100a)

If any section of the manual is not understood, contact your nearest Generac Mobile Products Authorized Service Dealer (ASD), or contact Generac Mobile Products Technical Service at 1-800-926-9768 or www.generacmobileproducts.com with any questions or concerns.

The owner is responsible for proper maintenance and safe use of the equipment. Comply with regulations the Occupational Safety and Health Administration (OSHA) has established, or with equivalent standards. Also, verify that the unit is applied, used, and maintained in accordance with the manufacturer's instructions and recommendations. Do nothing that might alter safe application/usage and render the unit in noncompliance with the aforementioned codes, standards, laws, and regulations.

Save these instructions for future reference. This manual contains important instructions for the unit that should be followed during setup, operation and maintenance of the unit and battery. ALWAYS supply this manual to any individual that will use this machine.

How to Obtain Service

When the unit requires servicing or repairs, contact a Generac Mobile Products Authorized Service Dealer (ASD) for assistance. Service technicians are factory-trained and are capable of handling all service needs.

For assistance locating an ASD, go to:

www.generacmobileproducts.com/parts-service/find-service

When contacting an ASD about parts and service, always supply the complete model number and serial number of the unit as given on the data label located on the unit. Record the model number and serial numbers in the spaces provided on the inside front cover of this manual.

See [Unit Serial Number Locations](#) in Section 2.

Safety Rules

The manufacturer cannot anticipate every possible circumstance that might involve a hazard. The warnings in this manual, and on tags and decals affixed to the unit are, therefore, not all inclusive. If using a procedure, work method or operating technique that the manufacturer does not specifically recommend, verify that it is safe for others. Also make sure the procedure, work method or operating technique utilized does not render the equipment unsafe.

Safety Symbols and Meanings

Throughout this publication, and on tags and decals affixed to the unit, DANGER, WARNING, CAUTION and NOTE blocks are used to alert personnel to special instructions about a particular operation that may be hazardous if performed incorrectly or carelessly. Observe them carefully. Their definitions are as follows:

DANGER

Indicates a hazardous situation which, if not avoided, will result in death or serious injury.

(000001)

WARNING

Indicates a hazardous situation which, if not avoided, could result in death or serious injury.

(000002)

CAUTION

Indicates a hazardous situation which, if not avoided, could result in minor or moderate injury.

(000003)

NOTE: Notes contain additional information important to a procedure and will be found within the regular text of this manual.

These safety alerts cannot eliminate the hazards that they indicate. Common sense and strict compliance with the special instructions while performing the action or service are essential to preventing accidents.

General Hazards



DANGER

Asphyxiation. Running engines produce carbon monoxide, a colorless, odorless, poisonous gas. Carbon monoxide, if not avoided, will result in death or serious injury.

(000103)



WARNING

Hearing Loss. Hearing protection is recommended when using this machine.

Failure to wear hearing protection could result in permanent hearing loss.

(000107)



WARNING

Moving Parts. Keep clothing, hair, and appendages away from moving parts. Failure to do so could result in death or serious injury.

(000111)



WARNING

Hot Surfaces. When operating machine, do not touch hot surfaces. Keep machine away from combustibles during use. Hot surfaces could result in severe burns or fire.

(000108)

WARNING

Only qualified service personnel may install, operate, and maintain this equipment. Failure to follow proper installation requirements could result in death, serious injury, and damage to equipment or property.

(000182)

WARNING

Risk of injury. Do not operate or service this machine if not fully alert. Fatigue can impair the ability to service this equipment and could result in death or serious injury.

(000215)



WARNING

Risk of burns. Allow engine to cool before draining oil or coolant. Failure to do so could result in death or serious injury.

(000139)

Explosion and Fire Hazards



⚠ DANGER

Explosion and Fire. Fuel and vapors are extremely flammable and explosive. Add fuel in a well ventilated area. Keep fire and spark away. Failure to do so will result in death or serious injury. (000105)



⚠ WARNING

Risk of Fire. Unit must be positioned in a manner that prevents combustible material accumulation underneath. Failure to do so could result in death or serious injury. (000147)



⚠ WARNING

Risk of Fire. Hot surfaces could ignite combustibles, resulting in fire. Fire could result in death or serious injury. (000110)

Trailer Hazards

⚠ WARNING

Trailer must be securely coupled to the hitch and the chains correctly attached. Uncoupled or unchained towing could result in death or serious injury. (000233)

⚠ WARNING

Do not operate this unit while transporting. Doing so could result in death or serious injury. (000231)

⚠ WARNING

Crushing hazard. Verify unit is properly secured and on level ground. An unsecured unit can suddenly roll or move, causing death or serious injury. (000234a)

⚠ WARNING

Property or Equipment Damage. Tighten wheel lug nuts after first 50 miles to factory specifications. Failure to do so could result in death, serious injury, property or equipment damage. (000235)

Electrical Hazards



⚠ DANGER

Electrocution. In the event of electrical accident, immediately shut power OFF. Use non-conductive implements to free victim from live conductor. Apply first aid and get medical help. Failure to do so will result in death or serious injury. (000145)



⚠ DANGER

Electrocution. Water contact with a power source, if not avoided, will result in death or serious injury. (000104)



⚠ DANGER

Electrocution. Contact with bare wires, terminals, and connections while generator is running will result in death or serious injury. (000144)



⚠ DANGER

Electrocution. Verify electrical system is properly grounded before applying power. Failure to do so will result in death or serious injury. (000152)



⚠ DANGER

Electrocution. Do not wear jewelry while working on this equipment. Doing so will result in death or serious injury. (000188)



⚠ DANGER

Electrocution. DO NOT use the unit if electrical cord is cut or worn through. Doing so will result in death or serious injury. (000263a)

Battery Hazards



⚠ DANGER

Electrocution. Do not wear jewelry while working on this equipment. Doing so will result in death or serious injury.

(000188)



⚠ WARNING

Explosion. Batteries emit explosive gases while charging. Keep fire and spark away. Wear protective gear when working with batteries. Failure to do so could result in death or serious injury.

(000137a)



⚠ WARNING

Explosion. Do not dispose of batteries in a fire. Batteries are explosive. Electrolyte solution can cause burns and blindness. If electrolyte contacts skin or eyes, flush with water and seek immediate medical attention.

(000162)



⚠ WARNING

Risk of burn. Do not open or mutilate batteries. Batteries contain electrolyte solution which can cause burns and blindness. If electrolyte contacts skin or eyes, flush with water and seek immediate medical attention.

(000163a)

⚠ WARNING

Environmental Hazard. Always recycle batteries at an official recycling center in accordance with all local laws and regulations. Failure to do so could result in environmental damage, death or serious injury.

(000228)

Always recycle batteries in accordance with local laws and regulations. Contact your local solid waste collection site or recycling facility to obtain information on local recycling processes. For more information on battery recycling, visit the Battery Council International website at: <http://batteryCouncil.org>

Fuel Hazards



⚠ DANGER

Explosion and fire. Fuel and vapors are extremely flammable and explosive. No leakage of fuel is permitted. Keep fire and spark away. Failure to do so will result in death or serious injury.

(000192)



⚠ DANGER

Risk of fire. Allow fuel spills to completely dry before starting engine. Failure to do so will result in death or serious injury.

(000174)

- **DO NOT** fill fuel tank near an open flame, while smoking, or while engine is running. **DO NOT** fill tank in an enclosed area with poor ventilation.
- **DO NOT** operate with the fuel tank cap loose or missing.

Engine Safety

Internal combustion engines present special hazards during operation and fueling. Failure to follow the safety guidelines described below could result in severe injury or death. Read and follow all safety alerts described in the engine operator's manual. A copy of this manual was supplied with the unit when it was shipped from the factory.

- **DO NOT** run engine indoors or in an area with poor ventilation. Make sure engine exhaust cannot seep into closed rooms or ventilation equipment.
- **DO NOT** clean air filter with gasoline or other types of low flash point solvents.
- **DO NOT** operate the unit without a functional exhaust system.
- Shut the engine down if any of the following conditions exist during operation:
 - Abnormal change in engine speed.
 - Loss of electrical output.
 - Equipment connected to the unit overheats.
 - Sparking occurs.
 - Engine misfires or there is excessive engine/ generator vibration.
 - Protective covers are loose or missing.
 - Ambient air temperature is above 120°F (49°C).

Operating Safety

Positioning the Unit



⚠ DANGER

High Voltage. Verify area above unit is clear of overhead wires and obstructions. Contact with high-voltage power lines will result in death or serious injury. (000260a)

- The area immediately surrounding the unit should be dry, clean, and free of debris.
- Position and operate the unit on a firm, level surface.
- If the unit is equipped with a frame grounding stud, follow any local, state, and National Electrical Code (NEC) guidelines when connecting.

Starting the Unit



⚠ DANGER

Electrocution. DO NOT use the unit if electrical cord is cut or worn through. Doing so will result in death or serious injury. (000263a)

- **DO NOT** start a unit in need of repair.

Towing Safety

Towing a trailer requires care. Both the trailer and vehicle must be in good condition and securely fastened to each other to reduce the possibility of an accident. Some states require that large trailers be registered and licensed. Contact your local Department of Transportation office to check on license requirements for your particular unit.

Hitch and Coupling

- Verify the hitch and coupling on the towing vehicle are rated equal to, or greater than, the trailer's Gross Vehicle Weight Rating (GVWR).
- Verify the trailer hitch and the coupling are compatible. Make sure the coupling is securely fastened to the vehicle.
- **DO NOT** tow trailer using defective parts. Inspect the hitch and coupling for wear or damage.
- Connect safety chains in a crossing pattern under the tongue.
- Before towing the trailer, verify the weight of the trailer is equal across all tires. On trailers with adjustable height hitches, adjust the angle of the trailer tongue to keep the trailer as level as possible.

Running Lights

Verify directional and brake lights on the trailer are connected and working properly.

Wheels and Tires

- Check trailer tires for wear and proper inflation.
- Verify wheel lug nuts are present and tightened to the specified torque.

Safe Towing Techniques

- Practice turning, stopping and backing up in an area away from heavy traffic prior to transporting the unit.
- Maximum recommended speed for highway towing is 45 mph (72 km/h). Recommended off-road towing speed is 10 mph (16 km/h) or less, depending on terrain.
- When towing, maintain extra space between vehicles and avoid soft shoulders, curbs and sudden lane changes.

Tandem Towing Safety

This unit is equipped with a tandem tow hitch. This feature allows the operator to tow a second MLT4060MVD Light Tower behind the unit.

- Do not use the tandem tow hitch to tow any other equipment other than a second MLT4060MVD.
- Local regulations may limit or prohibit tandem towing. There may be restrictions on towing speed, overall vehicle length, the types of roads on which the units can be towed, and which road lanes are permissible for towing vehicles. Check with the local authority having jurisdiction (for example, the state Department of Transportation) before using the tandem tow hitch.
- Connect the second MLT4060MVD using the same procedures and preventative safety measures as required for a single unit.

Reporting Trailer Safety Defects

If you believe your trailer has a defect which could cause a crash or could cause injury or death, you should immediately inform the National Highway Traffic Safety Administration (NHTSA) in addition to notifying Generac Mobile Products LLC.

If NHTSA receives similar complaints, it may open an investigation; and if it finds that a safety defect exists in a group of vehicles, it may order a recall and remedy campaign. However, NHTSA cannot become involved in an individual problem between you, your ASD, or Generac Mobile Products LLC.

To contact NHTSA, you may either call the Auto Safety Hotline toll-free at 1-888-327-4236 (TTY:1-800-424-9153), go to <http://www.safercar.gov>; or write to:

Administrator
NHTSA
1200 New Jersey Avenue S.E.
Washington, DC 20590

You can also obtain other information about motor vehicle safety from <http://www.safercar.gov>.

Safety and Operating Decals

See [Figure 1-1](#) and [Figure 1-2](#). This unit features numerous safety and operating decals. These decals provide important operating instructions and warn of dangers and hazards. The following diagrams illustrate decal locations and descriptions.

Replace any missing or hard-to-read decals and use care when washing or cleaning the unit. Decal part numbers can be found in the parts manual at www.generacmobileproducts.com.

ID	Description
A	Dangers: General Transport and Operating Safety
B	Electric Shock Hazard
C	Engine Safety
D	Ultra Low Sulfur Diesel
E	Forklift and Tie-Down Location
F	Towing Instructions
G	Cable Winding Instruction
H	Lifting Point
J	Hot Surface
K	Tie-Down Location
L	Owner's Manual Storage Location
M	Light Tower Setup Instructions
N	Rear Jack Storage
P	Position of Stowed Mast
Q	Outrigger Retraction Warning
R	Not A Step
S	Pressurized Coolant Hazard
T	Entanglement Hazard
U	Cutting Hazard
V	Hot Surface Warning: Do Not Remove Grille
W	Neutral Bonded To Frame
X	Electrical Ground
Y	Read Manual Before Operating
Z	Disconnect Battery Before Servicing

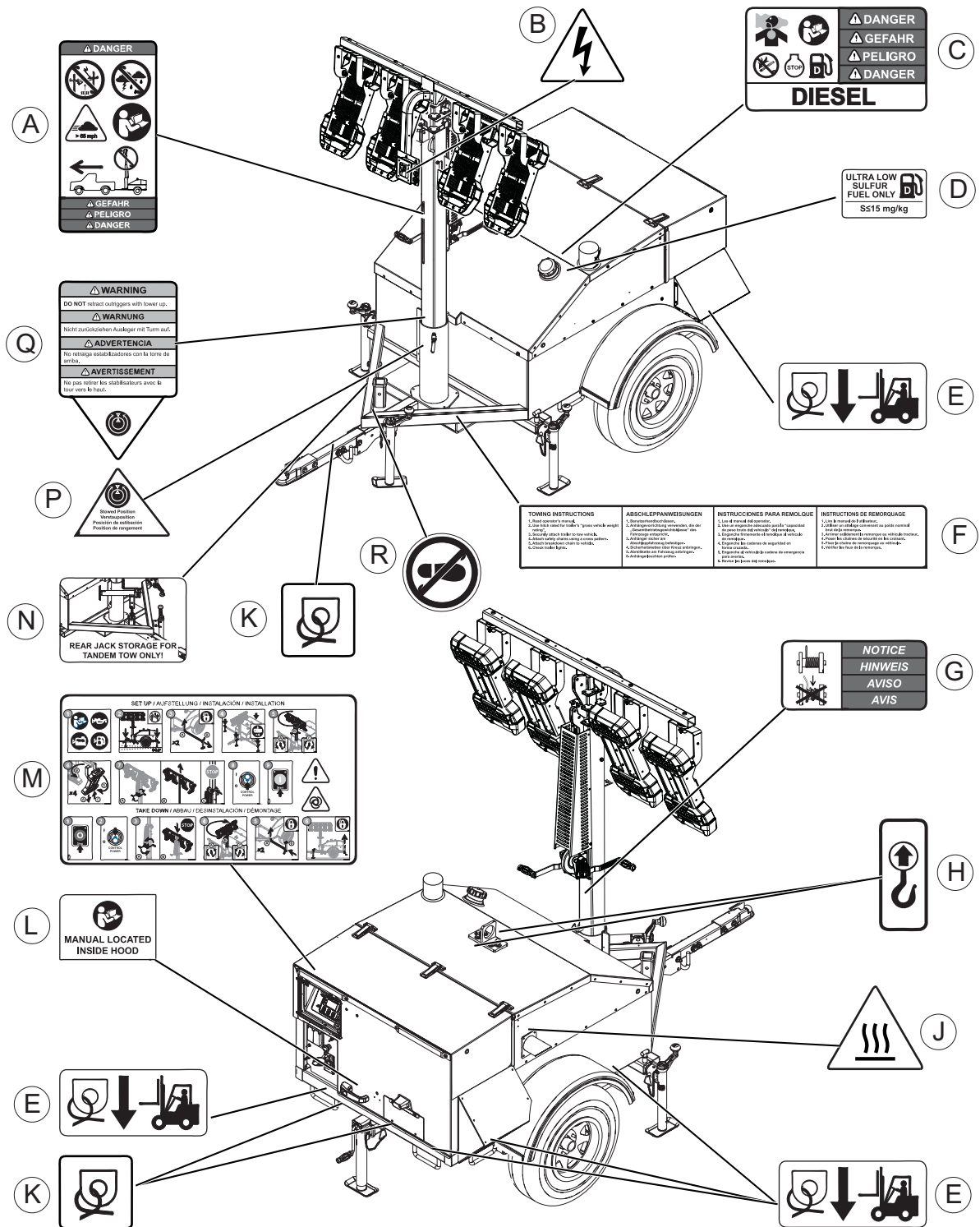

002324

Figure 1-1. External Decals

ID	Description
A	Dangers: General Transport and Operating Safety
B	Electric Shock Hazard
C	Engine Safety
D	Ultra Low Sulfur Diesel
E	Forklift and Tie-Down Location
F	Towing Instructions
G	Cable Winding Instruction
H	Lifting Point
J	Hot Surface
K	Tie-Down Location
L	Owner's Manual Storage Location
M	Light Tower Setup Instructions
N	Rear Jack Storage
P	Position of Stowed Mast
Q	Outrigger Retraction Warning
R	Not A Step
S	Pressurized Coolant Hazard
T	Entanglement Hazard
U	Cutting Hazard
V	Hot Surface Warning: Do Not Remove Grille
W	Neutral Bonded To Frame
X	Electrical Ground
Y	Read Manual Before Operating
Z	Disconnect Battery Before Servicing

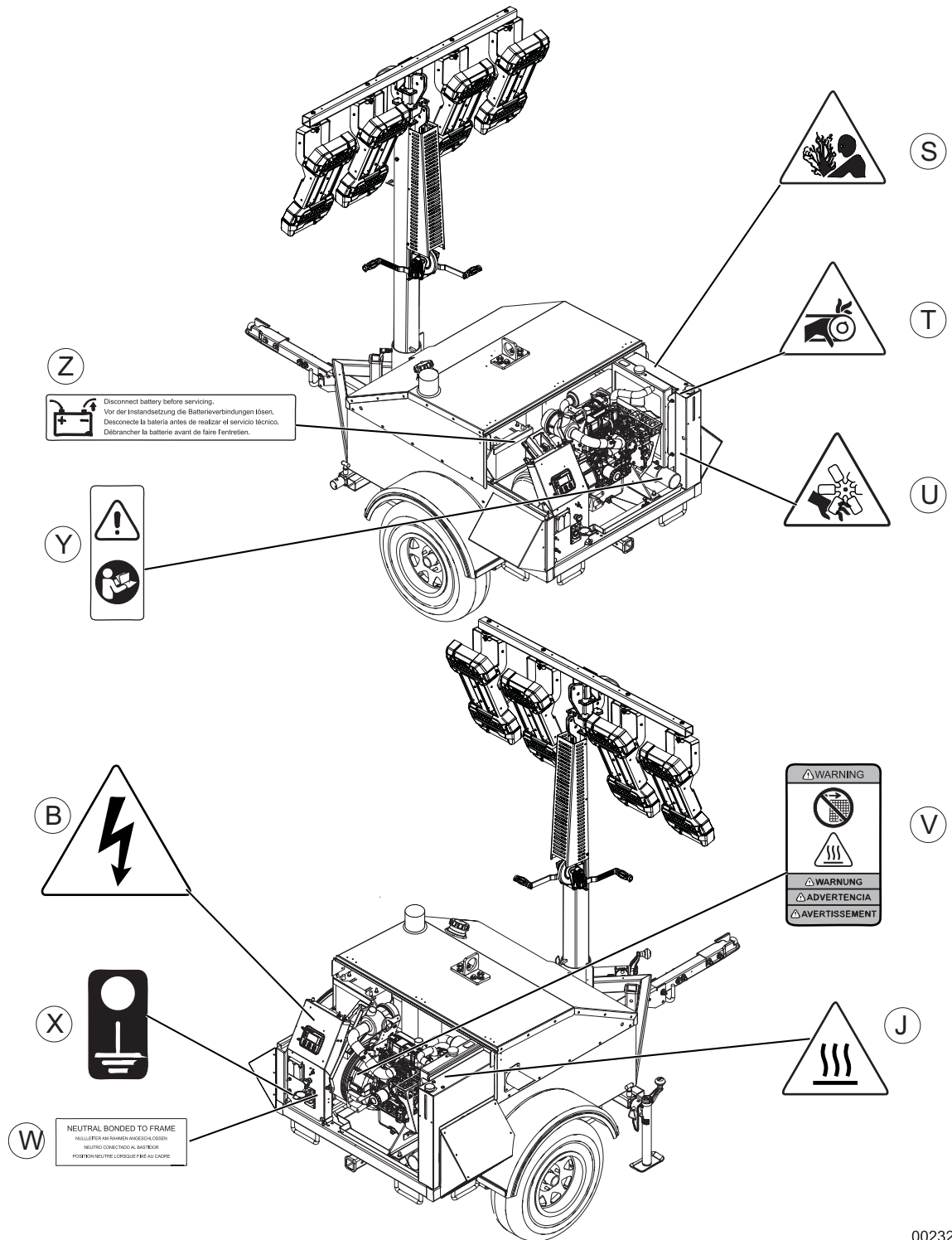

Figure 1-2. Internal Decals

002325

This page intentionally left blank.

Section 2: General Information

Specifications

DESCRIPTION	MLT4060MVD
Engine	
Manufacturer and Model	Mitsubishi L3E T4 NTE
EPA Tier	4f
Recommended Fuel	Ultra-Low Sulfur Diesel (ASTM 2-D)
Fuel Consumption—100% Prime	0.50 gph (1.89 Lph)
Fuel Consumption—75% Prime	0.35 gph (1.32 Lph)
Fuel Consumption—50% Prime	0.20 gph (0.76 Lph)
Battery Type—Group Number	24
Battery Voltage	12V (1)
Battery Rating	440 CCA (optional 720 CCA)
Generator	
Output - Standby	6.0 kW (6.0 kVA)
Output Voltage	120/240V, single phase
Output Amperes— 120V outlet Main (240V)	20A 30A (2-pole)
Frequency Hz	60 Hz
Weights	
Dry Weight	1694 lbs (768 kg)
Operating Weight	2770 lbs (1256 kg)
Capacities	
Fuel Tank Volume	117 gal (443 L)
Usable Fuel Volume	114 gal (431.5 L)
Coolant (including engine)	4.5 qt (4.3 L)
Oil (including filter)	5.0 qt (4.7 L)
Maximum Run Time	580 hr
AC Distribution	
Circuit Breaker Size	30A
Trailer	
Hitch—Standard	2 in. ball
Hitch—Optional	2 in. ball (“Bulldog” hitch)
Maximum Tire Pressure	50 psi (345 kPA)
<i>Specifications are subject to change without notice.</i>	

Unit Dimensions

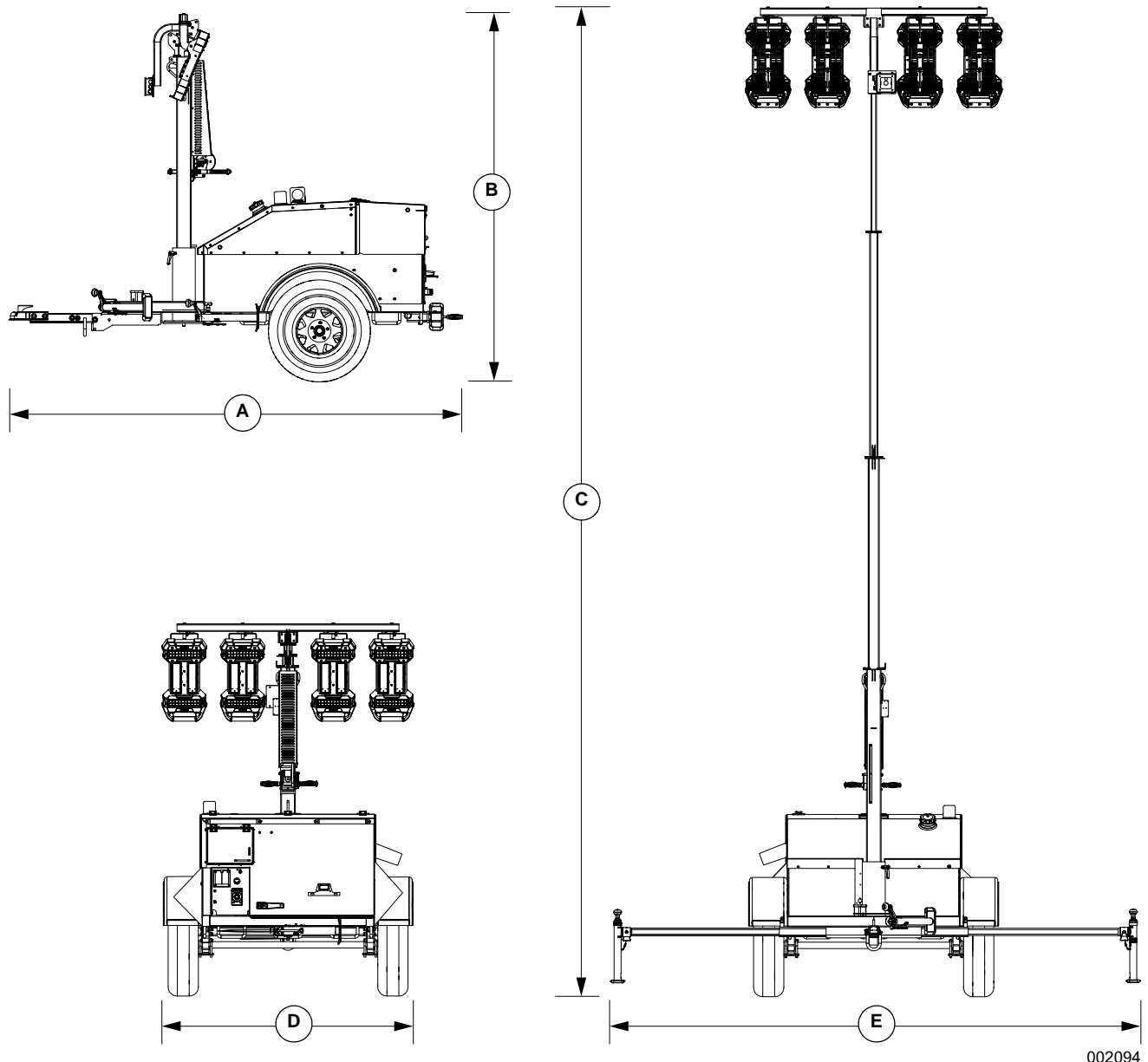

002094

Figure 2-1. Unit Dimensions

	A	B	C	D	E
MLT4060MVD	124.5 in (316.23 cm)	101.2 in (257.05 cm)	23 ft (7 m)	68.2 in (173.23 cm)	144.8 in (367.80 cm)

Specifications are subject to change without notice.

Unit Serial Number Locations

Refer to the illustration to locate the unit ID tag and Vehicle Identification Number (VIN) tag on the unit. Important information, such as the unit serial number, model number, VIN and tire loading information are found on these tags. Record the information from these tags so it is available if the tags are lost or damaged. When ordering parts or requesting assistance, you may be asked to provide this information.

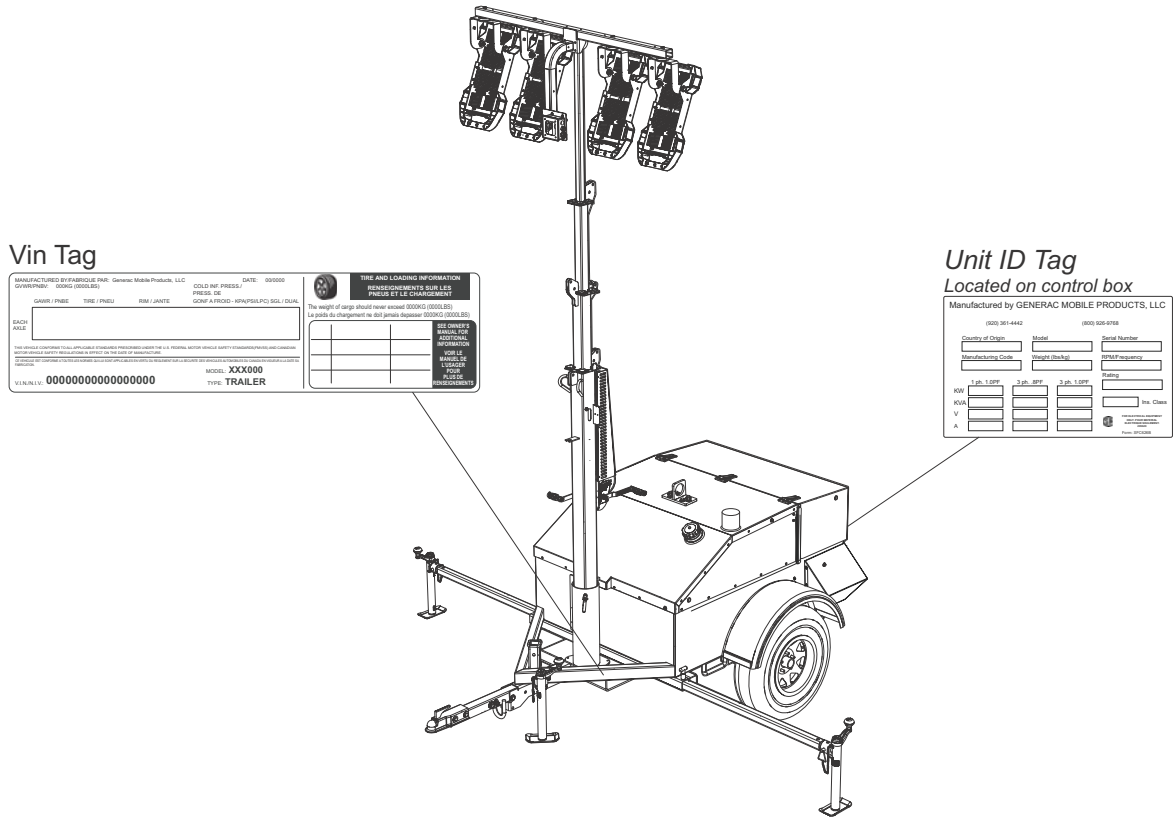
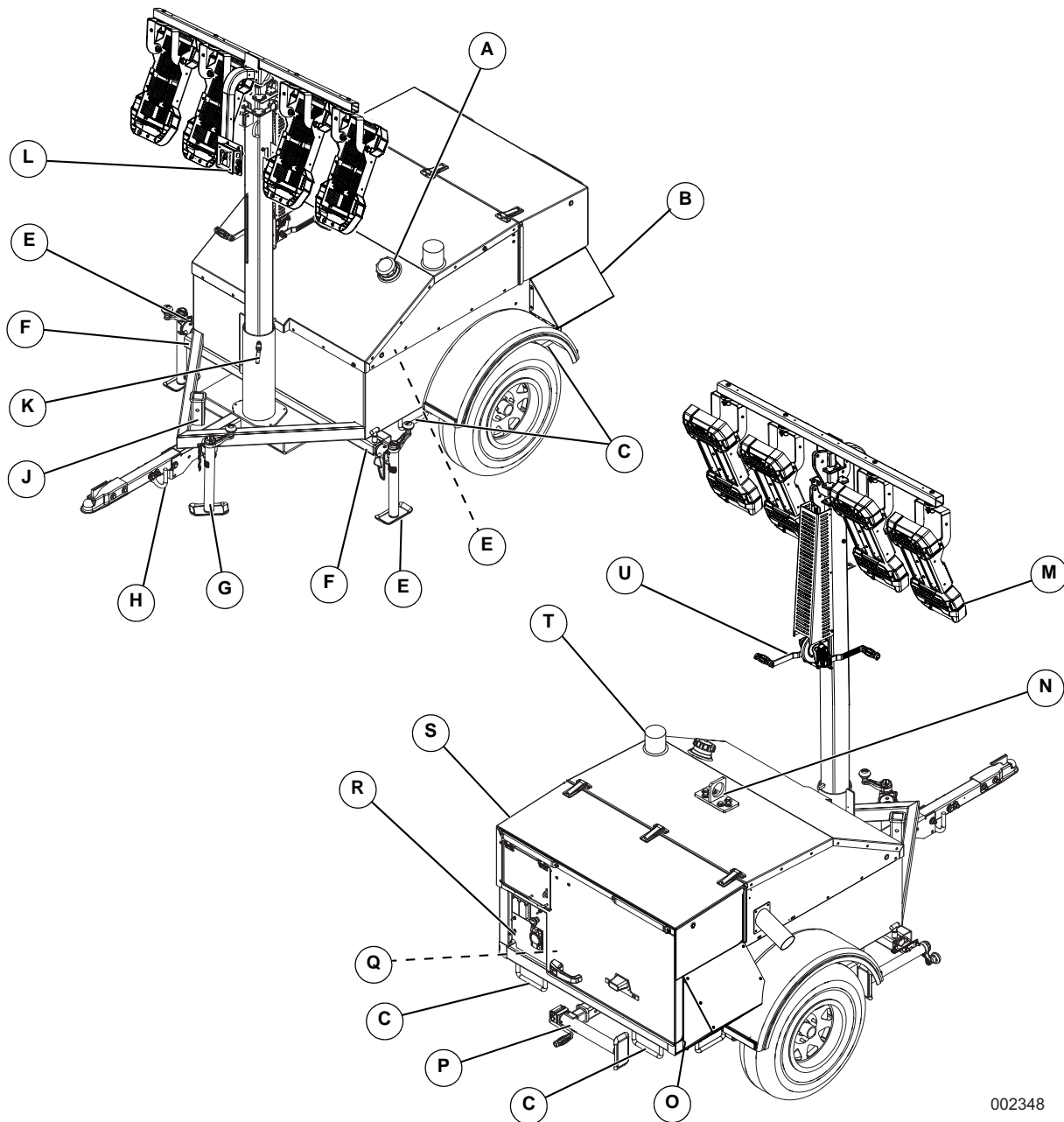

Figure 2-2. Serial Number Locations

003774

Component Locations



002348

Figure 2-3. Component Locations

- | | | | |
|---|---|---|--|
| A | Fuel fill | L | Junction box |
| B | Block heater (beneath cover) | M | Lights (4) |
| C | Forklift pocket and tie-down point | N | Central lift point |
| D | Battery charger (if equipped—not shown) | O | Snow hood |
| E | Outrigger jack (2) | P | Rear jack / Tandem tow hitch receiver |
| F | Outrigger (2) | Q | Battery disconnect (if equipped—not shown) |
| G | Tongue jack | R | Control box |
| H | Tie-down point | S | Engine access |
| J | Rear jack storage | T | Fuel level warning beacon |
| K | Mast rotation knob | U | Winch |

Control Panel

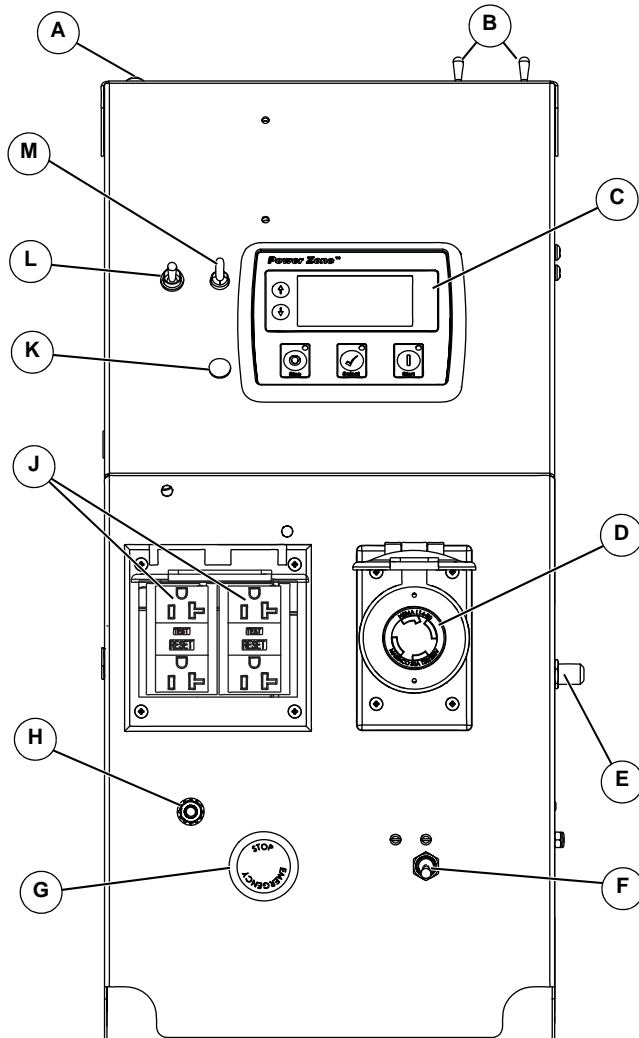

002349

Figure 2-4. Control Panel

Control Panel Features and Functions

(A) DC Circuit Breaker

Resets the DC electrical circuit that powers the control panel and engine components.

(B) Mast Light Circuit Breakers (2)

Circuit breakers for the LED light fixtures.

(C) PowerZone®-DLA

This controller serves as the main control unit for the Light Tower. See the following pages for details.

(D) 240V/30A Twist-Lock Receptacle (or 240V/30A RV Receptacle, if equipped)

Customer convenience outlet for connecting auxiliary equipment such as fans, pumps and drills.

(E) 120V Breakers (2)

Provides circuit protection for the 120V/20A GFCI outlet.

(F) 240V Breaker

Main disconnect and circuit protection for the 240V/30A twist-lock and 120V GFCI receptacles.

(G) Emergency Stop Button

Stops the engine immediately in an emergency. For more information, see [Emergency Stop](#).

(H) Ground Stud

An electrical grounding stud for connecting an earth ground to the unit if required. Follow local, state, or National Electric Code (NEC) guidelines.

(J) 120V/20A GFCI Receptacle

Customer convenience receptacle for use in connecting auxiliary equipment such as fans, pumps, drills. Includes a GFCI test and reset button.

(K) Mast Switch (electric winch units only)

Raises and lowers the mast on units equipped with an electric winch.

(L) Automatic Load Sense Switch

Automatic Load Sense works in tandem with the ECOSpeed engine to adjust engine operating speed according to lighting and export power requirements. The 240VAC receptacle breaker (F) must be ON to enable Automatic Load Sense.

- **Turning Automatic Load Sense switch ON** enables Automatic Load Sense—the default setting for normal export power operation.
- **Turning Automatic Load Sense switch OFF** disables Automatic Load Sense and allows the engine to run at high speed when the 240VAC outlet breaker (H) is ON. Use this setting when connecting equipment that requires a higher starting amperage, such as air conditioners, air compressors, or submersible pumps.

(M) Control Power Switch

Enables power supply to the Power Zone-DLA.

Keep Run Ambient Sensor (if equipped)

See [Figure 2-5](#) The unit may be equipped with a “keep run” ambient sensor (A).

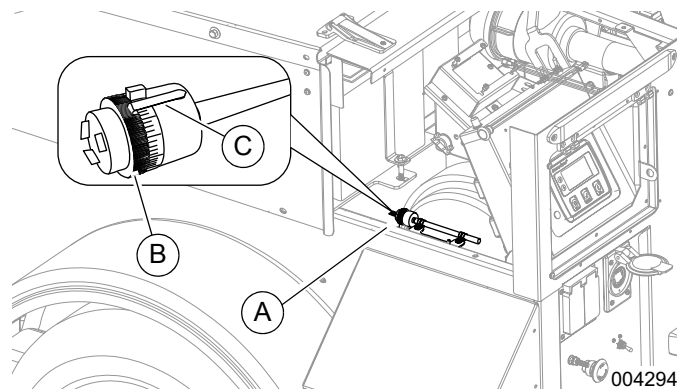

Figure 2-5. Keep Run Ambient Sensor

This adjustable thermostat allows continuous engine operation based on a user-selected low temperature threshold. The “keep run” feature starts the unit if the ambient temperature falls below the user-selected set point. If the unit is running and the low ambient set point is reached, it will continue to run until the ambient temperature rises above the set point.

The Keep Run Ambient Sensor is set to -10°F (-23°C). To adjust the sensor, unscrew the knurled ring (B). Move the pointer (C) left or right until it is directly above the desired temperature set point on the scale. Tighten the knurled ring to lock the pointer in place.

ECOSpeed™ Engine

This unit is equipped with an ECOSpeed engine that runs at variable speeds depending on the applied operational load. Operating temperature remains constant regardless of engine speed or applied loads.

- The engine runs at low speed when 1) the main breaker is open, or 2) if main breaker is closed, load sense switch is ON, and there is no electrical load on export power receptacles. The lower speed conserves fuel, reduces emissions and sound output, and extends total run time.
- The engine runs at high speed when the LED lights are turned on and the 240VAC/30A outlet breaker is ON. The higher speed maximizes export of clean 60 Hz power to the convenience outlets.

Refer to [Operation](#) for more information.

Positive Air Shutdown (PAS) (if equipped)

See [Figure 2-6](#). This unit may be equipped with a positive air shutdown (A) on the air intake. The PAS system automatically stops the engine if speed exceeds 2100 rpm. Engine overspeed can occur if the atmosphere contains elevated levels of combustible propane or natural gas.

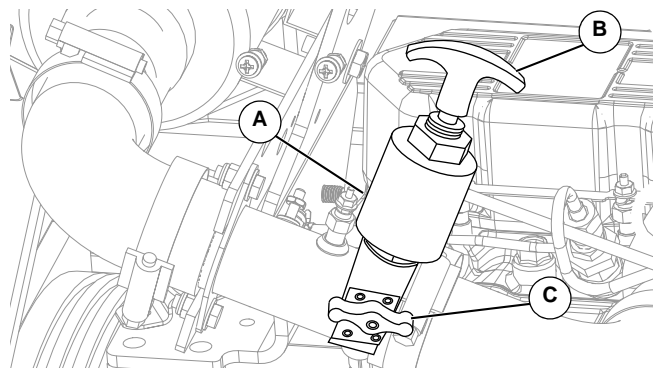

Figure 2-6. Positive Air Shutdown

The PAS system stops the engine by closing an internal valve and obstructing intake air. Shutdown is triggered automatically by an output from the controller, manually by pulling the T-handle (B), or by pressing the emergency stop button on the control panel.

The reset knob (C) rotates 90 degrees to block airflow. If the knob is parallel to the pipe centerline (as shown), the valve is open. If the knob is perpendicular to the pipe centerline, the valve is closed and airflow is blocked.

Test the PAS

Test the PAS at least once a month to ensure optimal valve performance.

Verify the engine is OFF before testing the PAS.

There are two methods of testing. **NOTE:** The main power and controller must be ON for each method.

1. Pull the T-handle. (**NOTE:** The valve must be open before testing.)
2. Press the emergency stop button. Testing the PAS triggers an actuator, closing the butterfly valve inside the valve body. An audible click can be heard when the actuator engages. Confirm that the valve is closed by verifying that the knob has rotated perpendicular to the pipe centerline. If valve does not close, contact Generac Mobile Products Technical Support.

Reset the PAS

IMPORTANT NOTE: Before resetting the PAS, turn the Control Power switch OFF (O). This will prevent unexpected engine start-up during the procedure.

1. Rotate the reset knob (C) and hold it in place while pulling the T-handle until knob rotates counter-clockwise into plunger detent. An audible “click” indicates the knob has seated properly
2. Verify that the knob is parallel to the intake pipe centerline.
3. Release T-handle, and then release knob. Knob should remain parallel to the intake pipe centerline.

Lower Radiator Hose Heater (if equipped)

Use and Maintenance

The lower radiator hose heater is designed to enable engine start-up in extreme cold weather conditions by warming the engine coolant. While the heater is designed to be operated overnight if necessary, two to five hours of heating just prior to starting is usually sufficient for proper engine starting.

NOTE: Use the lower radiator hose heater only in its designated location. Improper use can damage the engine.

Perform the following steps when operating a unit equipped with a lower radiator hose heater.

1. Verify the unit is level so as to maintain proper orientation of the heater while it is in operation.
2. Verify the cooling system is full of the proper mixture of water and engine coolant before each heater use.
3. Use only an undamaged, outdoor rated, three-prong grounded 120VAC extension cord with a minimum amperage rating of 10A. Connect the cord to a properly grounded 120VAC, GFCI outlet.
4. Before starting the engine, unplug the extension cord from the power first, then unplug the heater cord set from the extension cord.

Diesel Fired Block Heater (if equipped)

See [Figure 2-7](#). A diesel fired block heater (A) is located at the rear of the unit beneath a protective cover. Coolant is drawn through the heater by an internal electric pump, and warmed by a diesel-fueled burner. Heated coolant is then circulated through the engine block and returned to the heater where the cycle is repeated.

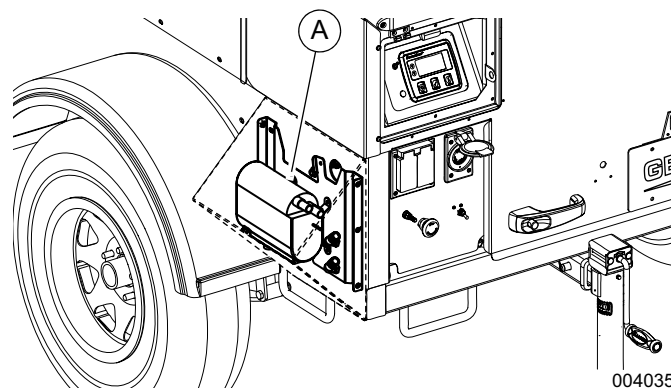

Figure 2-7. Diesel Fired Block Heater

The diesel fired block heater operates automatically when the unit is set to “dusk to dawn” mode. The heater does NOT operate when the unit is manual mode unless the unit is equipped with a Keep Run Ambient Sensor. See [Preparing for Start-Up](#) for more information about unit operating modes.

NOTE: The controller initiates the start sequence when the heater reaches a coolant temperature of 86°F (30°C). The sequence begins with a 3 minute start delay, followed by a 15 second preheat and crank delay period during which the fuel pump and glow plugs are energized.

NOTE: Ten consecutive failed start attempts will trigger a lockdown condition. The unit will not operate until reset by a GMP ASD. Contact Technical Support at 1-800-926-9768 for assistance.

Heated Fuel Filter (if equipped)

See **Figure 2-8**. An optional heated fuel filter (A) prevents diesel fuel from gelling in extremely cold temperatures. Heating cycles are automatically controlled by the Power Zone–DLA.

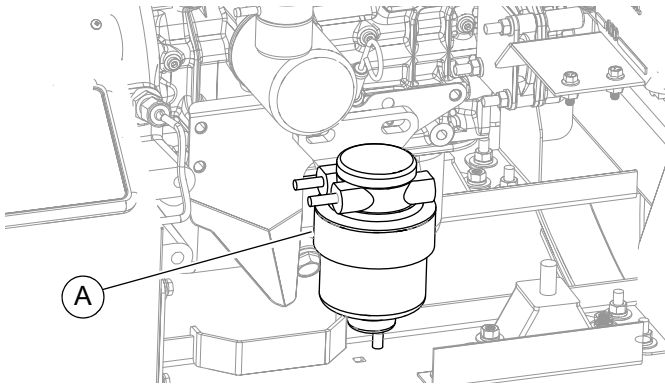

Figure 2-8. Heated Fuel Filter

Battery Disconnect (if equipped)

See **Figure 2-9**. This unit may be equipped with a battery disconnect switch (A). This lockable switch temporarily removes the battery from the unit electrical circuit without actually disconnecting the battery cables.

NOTE: A padlock is not included with this unit and must be supplied by the customer.

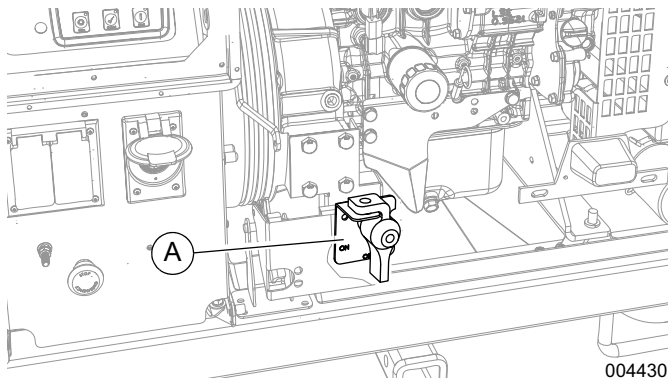

Figure 2-9. Battery Disconnect

Telemetry (if equipped)

The digital telemetry option enables the operator to remotely monitor the unit fuel level. A transmitter inside the engine compartment sends a text message to the operator when the fuel level falls below a preset volume. At the same time, a beacon mounted atop the hood flashes to indicate that the fuel level is low.

Spark Arrester (if equipped)

A spark arrester, installed on the engine exhaust, may be required by code in certain municipalities. Check with the local authority having jurisdiction to determine whether or not a spark arrester must be installed on the unit before operation.

Power Zone–DLA

See **Figure 2-10**. The Power Zone–DLA (Digital Light Tower Autolight) is an auto start controller that monitors the unit and indicates operational status and fault conditions. The controller can be programmed to automatically start or stop based on time schedule, fault condition, or load demand.

The controller constantly monitors vital generator and engine functions for a number of preprogrammed alarm and fault conditions. When a fault condition occurs, the engine will be shut down automatically and the LCD window will show the fault that caused the shutdown. To resume operation, the fault condition must be corrected.

This controller also records a history of unit performance, which may be viewed at any time and will not be lost when the controller is powered down.

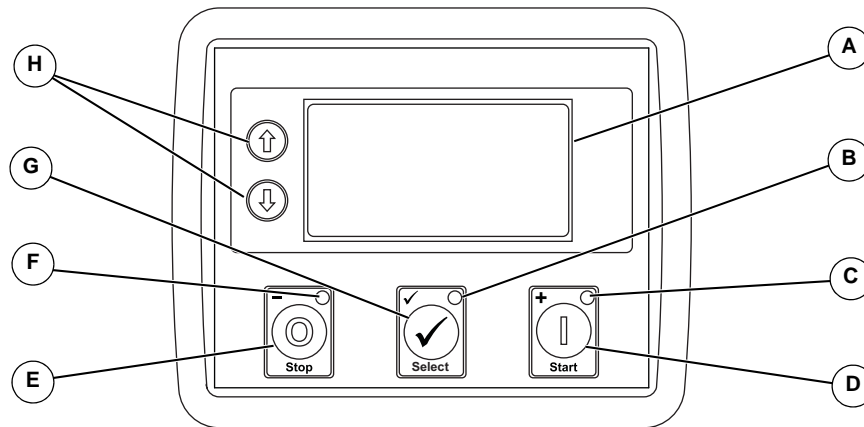

Figure 2-10. Power Zone-DLA Layout

Controller Features and Functions

(A) The Liquid Crystal Display (LCD) Window

This window displays the various operating screens. By viewing these screens, the operator can monitor both the engine and generator status while the unit is running.

(B) Select LED

This LED illuminates when the unit is running in AUTO mode.

(C) Start LED

This LED illuminates when the unit is running in MANUAL mode.

(D) Start Button

This button starts the engine if there are no shutdown errors and the engine is in “ready to start” status.

(E) Stop Button

This button shuts down the unit and puts the controller into STOP mode, whether in MANUAL mode or AUTO mode.

NOTE: To prevent damage to the generator and connected equipment, remove all loads from the generator by opening all circuit breakers (turn to the OFF [O] position) before pressing the stop button.

(F) Stop LED

This LED illuminates when the unit is in STOP mode and flashes when an Electrical Trip and Shutdown Fault has occurred.

(G) Select Button

This button confirms entries chosen in the various edit menus and screens.

(H) Menu Navigation

These buttons (↑, ↓) are used to navigate through the various operator screens.

Operator Screens

See [Figure 2-11](#). The operator screens display the most relevant and critical information an operator will need to properly configure and use the unit. From these six screens, the operator can access information necessary to operate the unit under normal conditions.

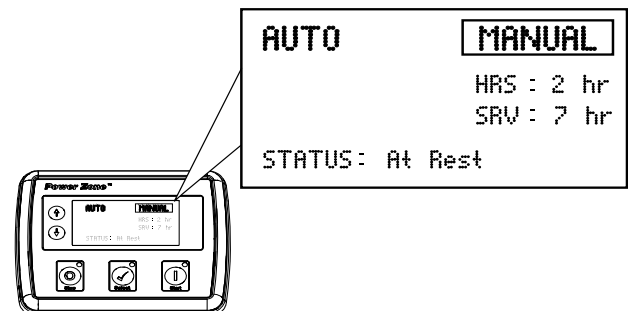

Figure 2-11. Operator Screens Location

Home Screen

See [Figure 2-12](#). The Home screen is the default screen of the controller and displays after the controller is powered up and the unit management software is loaded. It displays the controller mode, total operating hours, hours left until the next service interval, engine operating status, and engine RPM. If the unit is in AUTO mode, the Home screen may also display whether the scheduler or “dusk to dawn” are enabled.

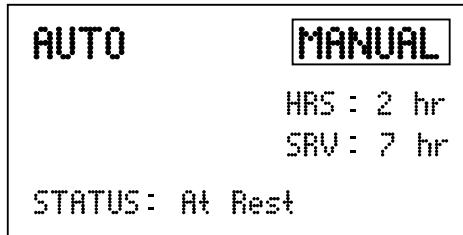

Figure 2-12. Home Screen

Engine Screen

- See [Figure 2-13](#). The Engine screen displays battery voltage, oil pressure, coolant temperature and fuel level.

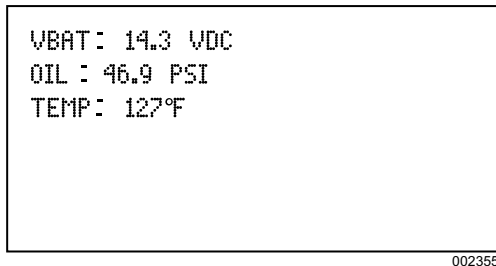

Figure 2-13. Engine Screen

- VBAT: Displays the engine battery voltage. A normal reading is 12-14V on 12 volt systems and 24-26V on 24V systems (with the engine running).
- OIL: Displays engine oil pressure. Normal operating pressure is between 35-80 psi (241-552 kPa).
- TEMP: Displays engine coolant temperature. Normal operating temperature of the unit is between 100-230°F (38-110°C).

Lights Screen

See [Figure 2-14](#). The Lights screen enables the operator to turn the lights on and off. Refer to [Light Operation](#) for more information.

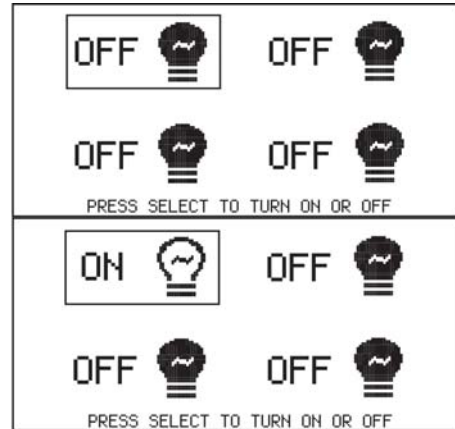

Figure 2-14. Lights Screen

Dusk to Dawn Screen

NOTE: This feature will only work in AUTO mode.

See [Figure 2-15](#). The Dusk to Dawn screen enables or disables the “dusk to dawn” function. This function uses a photo sensor to detect the surrounding light level, automatically starting the engine and turning the lights on at dusk. The engine will run and the lights will remain illuminated until dawn.

For instructions on using the Dusk to Dawn feature, see [Dusk to Dawn Sensor](#).

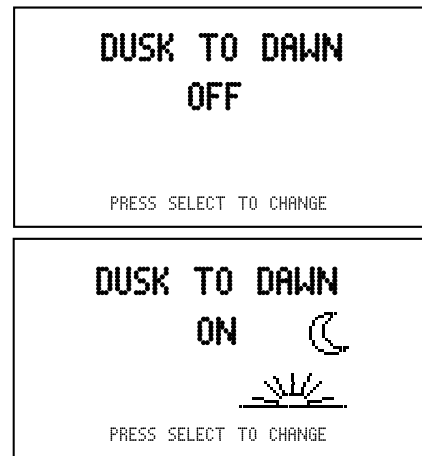
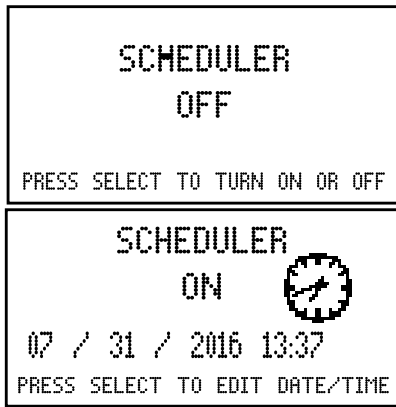

Figure 2-15. Dusk to Dawn Screen

NOTE: This feature will only work in AUTO mode and with a photo sensor.

Scheduler Screen

See [Figure 2-16](#). The Scheduler screen enables the operator to program specific times for the lights to turn on and off. Once programmed, the Scheduler will start the engine and illuminate the lights until the designated shutdown time.



002329

Figure 2-16. Scheduler Screen

NOTE: This feature will only work in AUTO mode.

Maintenance Screens

See [Figure 2-17](#). The information displayed on the maintenance screens can be used to identify, diagnose and troubleshoot unit shutdown conditions and poor unit performance.

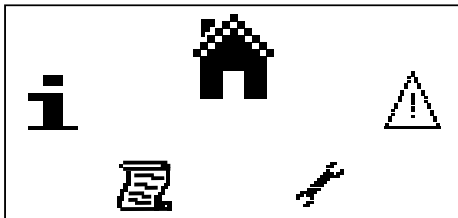

Figure 2-17. Maintenance Screens

Icon	Description
	Home screen
	Alarms screen
	Maintenance screen
	Event log screen
	About screen

To enter the navigation menu, use the following procedure:

1. Press both the ↑ and ↓ buttons simultaneously.

2. To select the required icon, press the ↑ button to cycle right and the ↓ button to cycle left until the desired operator screen section is reached.
3. Once the desired icon is at the top, press the Select (✓) button to enter that operator screen section.

NOTE: Every time the operator screens are entered, the home icon will be located at the top of the screen.

Alarms Screen

See [Figure 2-18](#). The Alarms () screen displays all the alarms, warnings, and engine Diagnostic Trouble Code (DTC) faults. When an alarm occurs, the controller automatically switches to this screen and remains there until the alarm is cleared. The Stop LED also flashes.

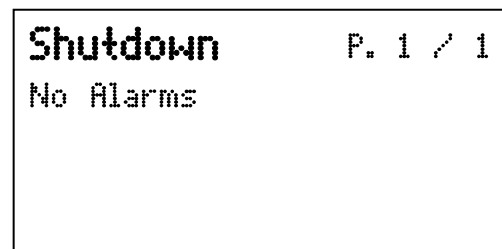

Figure 2-18. Alarms Screen

- **Warnings** are non-critical alarm conditions and do not affect the operation of the generator system. They serve to draw the operator’s attention to an undesirable condition. By default, warning alarms are self-resetting when the fault condition is removed.
- **Electrical trips** stop the generator in a controlled manner. On initiation of the electrical trip condition, the controller de-energizes all the outputs, including the lights, to remove the load from the generator. Once this has occurred, the controller starts the cooling timer and allows the engine to cool off-load before shutting down the engine.
- **Shutdown alarms** stop the generator immediately. On initiation of the shutdown condition, the controller de-energizes all the outputs, including the lights, to remove the load from the generator. Once this has occurred, the controller shuts the generator set down immediately to prevent further damage.

DTC faults are displayed by the controller.

Table 2-1. Possible DTC Faults

Fault	DTC Description
Check Engine Fault	A fault not recognized by the controller has been detected. Contact the engine manufacturer for support.
Low Oil Pressure	Engine oil pressure has fallen below its configured low oil pressure alarm level.
Underspeed	Engine speed has fallen below its configured underspeed alarm level.
Overspeed	Engine speed has risen above its configured overspeed alarm level.
Low Fuel Level	Engine's fuel level has fallen below its configured low fuel level alarm.
Battery Under/Over Voltage	Engine's DC supply has fallen below or risen above its configured alarm level.

To view the active alarms, repeatedly press the ↑ and ↓ buttons until the LCD window displays the alarm.

Continue to press the ↑ and ↓ buttons to cycle through the alarms.

To exit the alarm screen, press the ↑ and ↓ buttons simultaneously to enter the navigation menu. Once entered, cycle to the desired operator screen.

NOTE: The alarm condition must be corrected before a reset will take place. If the alarm condition remains, it is not possible to reset the unit. The exception to this is the Low Oil Pressure alarm and similar 'active from safety on' alarms, as the oil pressure is low with the engine at rest.

To clear alarms that stop the generator, refer to [Resetting the Maintenance Alarms](#).

NOTE: The LCD backlight is on if the unit has sufficient voltage while the unit is turned on, unless the unit is cranking. In this case, the backlight is turned off.

If the controller is left in STOP mode for a period of inactivity, the controller enters POWER SAVE mode. To 'wake' the controller, press the Stop (O) button.

Maintenance Screen

See [Figure 2-19](#). The Maintenance screen (🔧) displays the maintenance alarms configured into the controller. The three alarms are for servicing the fuel filter, oil filter, and air filter.

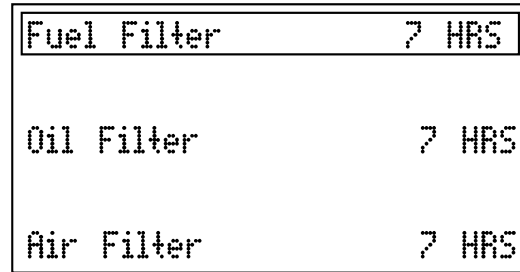

Figure 2-19. Maintenance Screen

Event Log Screen

See [Figure 2-20](#). The controller's event log (📖) displays a list of the last 15 recorded electrical trips or shutdown events and the engine hours at which they occurred. Once the log is full, any subsequent electrical trip or shutdown alarm overwrites the oldest entry in the log. Therefore, the log always contains the most recent shutdown alarms.

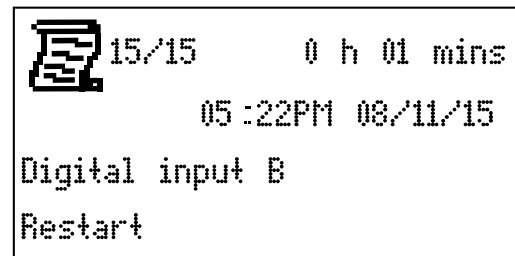

Figure 2-20. Event Log Screen

To view the event log:

1. Press both ↑ and ↓ buttons simultaneously to display the navigation menu.
2. Cycle to the event log section and press the Auto button to enter.
3. Repeatedly press the ↑ or ↓ buttons until the LCD window displays the desired event.

Continuing to press down the ↑ or ↓ buttons will cycle through past alarms. Eventually the most recent alarm will display and the cycle begins again.

To exit the event log, press the ↑ and ↓ buttons simultaneously to enter the navigation menu. Once entered, cycle to the desired operator screen.

About Screen

See [Figure 2-21](#). The About () screen contains information about the controller such as the controller's date and time, the product and USB identification number, and the application and engine version.

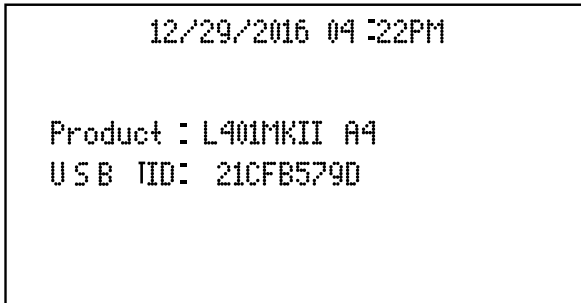

Figure 2-21. About Screen

This page intentionally left blank.

Section 3: Operation

Light Tower Setup

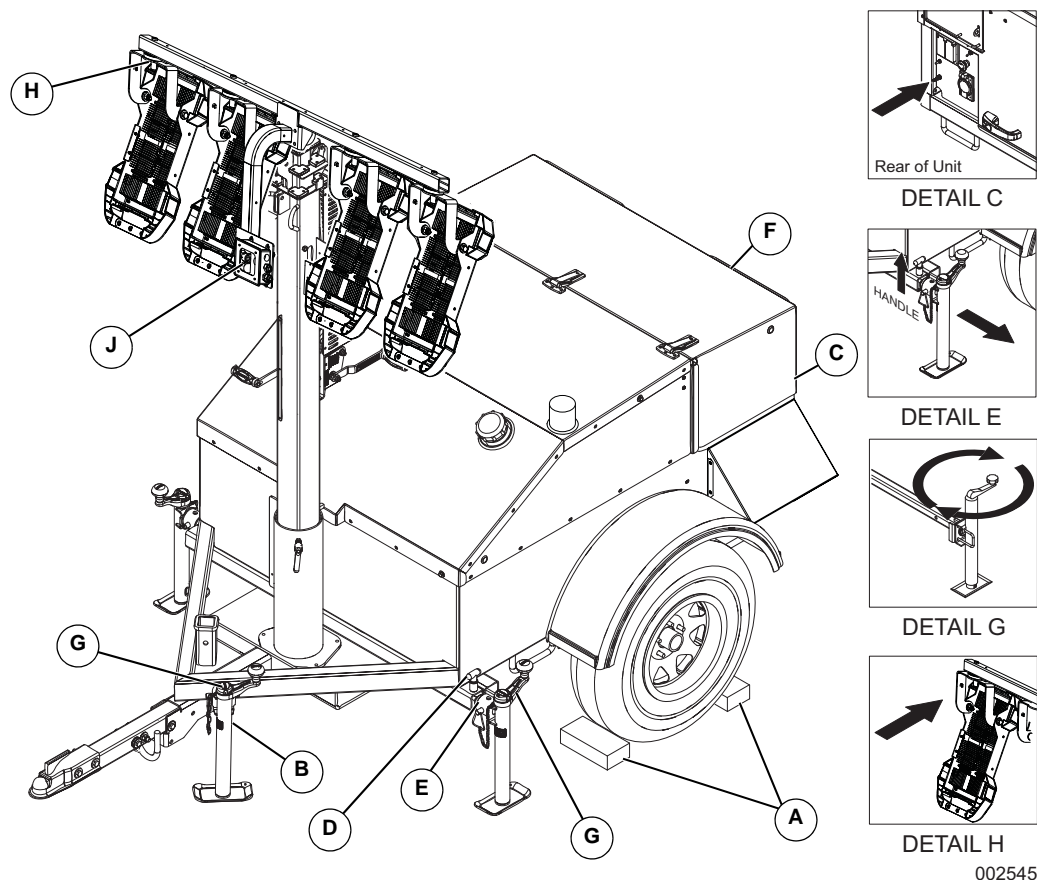

Figure 3-1. Set Up Outriggers and Jacks



⚠ DANGER

High Voltage. Verify area above unit is clear of overhead wires and obstructions. Contact with high-voltage power lines will result in death or serious injury.

(000260a)

1. For maximum light coverage, position the unit at ground level or in a spot higher than the area being illuminated by the lamps.

NOTE: The mast extends up to 23 ft (7 m).

2. See **Figure 3-1**. Place the unit on firm ground that is relatively flat, and then block the wheels (A) to keep it from moving. This will make it easier to level the unit.
3. Pull the locking pin (B) on the tongue jack and rotate the jack 90°. Reinstall the locking pin. Turn the jack handle clockwise to raise the trailer tongue off of the towing vehicle.

4. A grounding stud (C) is located on the control box. For grounding requirements, follow any local, state, or National Electrical Code (NEC) guidelines.
5. See Detail E. Pull the locking pin (D) on the outrigger (E) and pull each outrigger out until the spring loaded locking pin snaps back into place. Pull the locking pin on the outrigger jack and rotate each jack 90° so the jack pad is facing down. Reinstall the locking pin.
6. Pull the locking pin on the rear jack (F) and rotate the jack 90°. Reinstall the locking pin. Rotate the jack handle clockwise to start leveling the trailer (see Detail G). Adjust all four jacks by rotating their handles (G) clockwise until they are firmly in contact with the ground and the trailer is as level as possible.
7. See Detail H. Before raising the mast, it may be necessary to adjust the lamps. The lamps may be adjusted up, down, left or right by simply aiming them in the desired direction.

Fuel Recommendations

IMPORTANT: DO NOT use home heating oil or bio-diesel fuel.

Use No. 2D diesel fuel when temperatures are above freezing. When temperatures are below freezing, blend No. 1D diesel fuel and No. 2D diesel fuel together (50/50 ratio) to adjust for the ambient temperature.

Diesel fuel must also meet the following requirements:

- Sulfur content of 15 parts per million (ppm) maximum
- Minimum Cetane index of 40.

NOTE: Low ambient temperatures as well as operation at high altitudes may require the use of fuels with higher Cetane ratings.

Engine Oil Recommendations

To maintain the product warranty, the engine oil should be serviced in accordance with the recommendations of this manual. Refer to [Figure 3-2](#).



Engine damage. Verify proper type and quantity of engine oil prior to starting engine. Failure to do so could result in engine damage.

(000135)

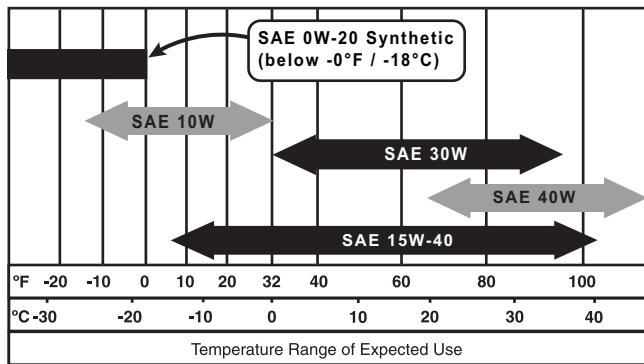

Figure 3-2. Engine Oil Recommendations

Coolant Recommendations



Engine damage. Use approved coolant only. Failure to do so could result in equipment damage.

(000323)

Improper coolant can damage the engine cooling system. Use demineralized water or distilled water for best results. Hard water causes scale deposits, which reduces cooling efficiency and raises internal temperatures, possibly leading to engine damage. Use an anti-corrosive to prevent rot in summer and anti-freeze to prevent freezing in winter.

Standard Units

The use of a long-life ethylene glycol coolant (LLC) at 60% concentrate. (40% water) is recommended. When operating in ambient temperatures above 0°F (-18°C), use a 50/50 ratio.

Cold Climate / Arctic Package Units

The cooling system is pre-filled with extended-life ethylene glycol coolant blend (60/40) rated for heavy duty use to a maximum freezing point of -62°F (-52°C).

Prestart Checklist

Before starting the unit, all items in the prestart checklist must be completed. This checklist applies to both manual and remote starting of the unit.



Consult Manual. Read and understand manual completely before using product. Failure to completely understand manual and product could result in death or serious injury.

(000100a)

- Verify all maintenance procedures are up to date. For more information, refer to [General Maintenance](#) and [Table 4-1](#).
- Level the unit.
- Verify the unit is dry. Look for water inside or near the unit; dry if needed.
- For grounding requirements, follow any local, state, or National Electrical Code (NEC) guidelines.
- Verify the Control Power switch is OFF (O).
- Verify all circuit breakers are OFF (O).
- Verify that the Emergency Stop Switch is pulled out.
- Verify that the [Positive Air Shutdown \(PAS\) \(if equipped\)](#) is reset.
- Inspect all electrical cords; repair or replace any that are cut, worn, or bare.

- Verify all winch cables are in good condition and centered on each pulley. Do not use if cables are kinked or beginning to unravel.
- Check oil, coolant, and fuel levels. For more information, refer to **General Maintenance**.
- Verify battery connections are secure.
- Check the engine fan belt tension and condition.
- Check the engine fan belt guard.
- Check the engine exhaust system for loose or rusted components.
- Verify all covers are in place and secure.
- Turn the battery disconnect switch ON (if equipped).

Raising the Mast—Manual Winch

IMPORTANT NOTE: The mast is intended for use **ONLY** to support the LED fixtures. Do not use the mast as a hoist or for any other purpose.

1. Set up and level the unit. See **Light Tower Setup**.



⚠ DANGER

Electrocution. DO NOT use the unit if electrical cord is cut or worn through. Doing so will result in death or serious injury.

(000263a)

⚠ WARNING

Tipping hazard. Extend the outriggers and level the unit before raising the mast. Keep the outriggers extended while the mast is up. Failure to do so could cause the unit to tip and fall and could result in death or serious injury.

(000266)

2. See **Figure 3-3**. Check the mast cables for excessive wear or damage. Make sure the cables are properly centered in each pulley (A). Check the coiled electrical cord for damage.
3. Rotate the mast by loosening the mast rotation knob (C) at the bottom of the mast. Turn the mast until the lights face in the desired direction, and then tighten the mast rotation knob to secure the mast in position.
4. See **Figure 3-3**. Use the winch (B) to slowly extend the mast, making sure that the coiled electrical cord is extending at the top sections of the mast. STOP extending the mast when the colored mark on the second mast section is visible as seen in Detail B.

IMPORTANT NOTE: Contact an ASD immediately if the mast hangs up or the winch cable develops slack.

⚠ WARNING

Machine damage. Do not extend the mast beyond the colored mark. Overextension can stretch or break electrical cables or winch cables, and may damage mast hardware.

(000372)

⚠ WARNING

Tipping hazard. Do not extend the mast beyond the colored mark on the second mast section. The unit can become unstable and tip or fall, causing injury.

(000262)

⚠ WARNING

Personal Injury. Stop immediately if the mast hangs up or the winch cable develops slack. Excess slack could cause the mast to collapse, resulting in personal injury or equipment damage.

(000265)

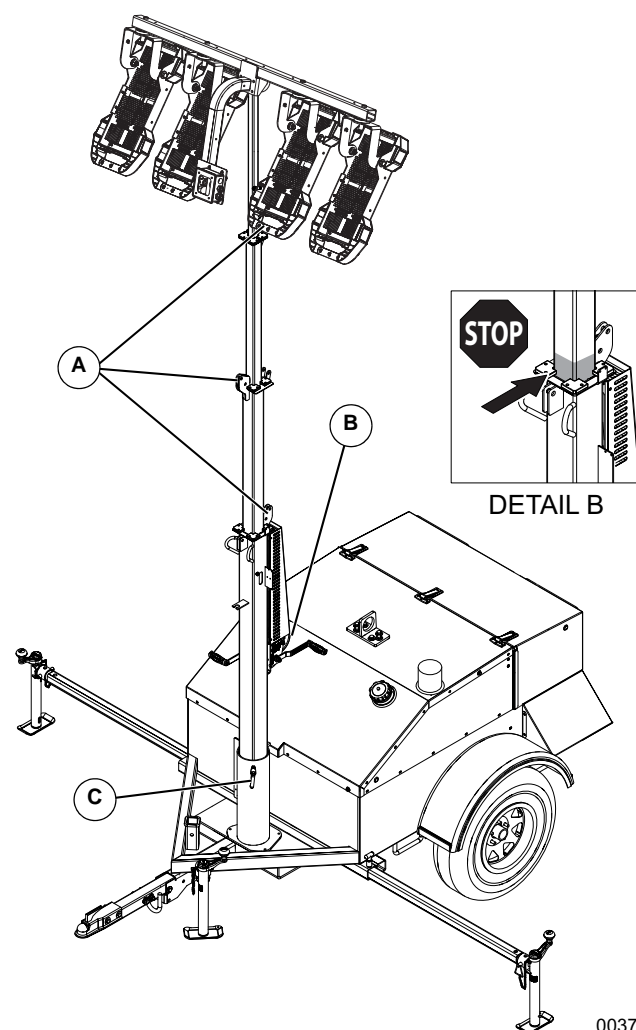

003776

Figure 3-3. Winch and Pulley Locations—Manual

Raising the Mast—Electric Winch (if equipped)

IMPORTANT NOTE: The mast is intended for use **ONLY** to support the LED fixtures. Do not use the mast as a hoist or for any other purpose.

1. Set up and level the unit. See [Light Tower Setup](#).



DANGER

Electrocution. DO NOT use the unit if electrical cord is cut or worn through. Doing so will result in death or serious injury.

(000263a)

WARNING

Tipping hazard. Extend the outriggers and level the unit before raising the mast. Keep the outriggers extended while the mast is up. Failure to do so could cause the unit to tip and fall and could result in death or serious injury.

(000266)

2. See [Figure 3-4](#). Check the mast cables for excessive wear or damage. Verify the cables are properly centered in each pulley (A). Check the electrical cord for damage.
3. Rotate the mast by loosening the mast rotation knob at the bottom of the mast (D). Turn the mast until the lights face in the desired direction and then tighten the mast rotation knob to secure the mast in position.
4. Press and hold the winch control switch (C) upward to telescope the mast to the desired height. Extend the mast slowly, and verify the coiled electrical cord is extending at the top sections of the mast.

IMPORTANT NOTE: A limit switch on the main mast section will disconnect power to the upper electric winch to prevent overextending the mast.

WARNING

Machine damage. Do not extend the mast beyond the colored mark. Overextension can stretch or break electrical cables or winch cables, and may damage mast hardware.

(000372)

WARNING

Tipping hazard. Do not extend the mast beyond the colored mark on the second mast section. The unit can become unstable and tip or fall, causing injury.

(000262)

WARNING

Personal Injury. Stop immediately if the mast hangs up or the winch cable develops slack. Excess slack could cause the mast to collapse, resulting in personal injury or equipment damage.

(000265)

IMPORTANT NOTE: Contact an ASD immediately if the mast hangs up or the winch cable develops slack.

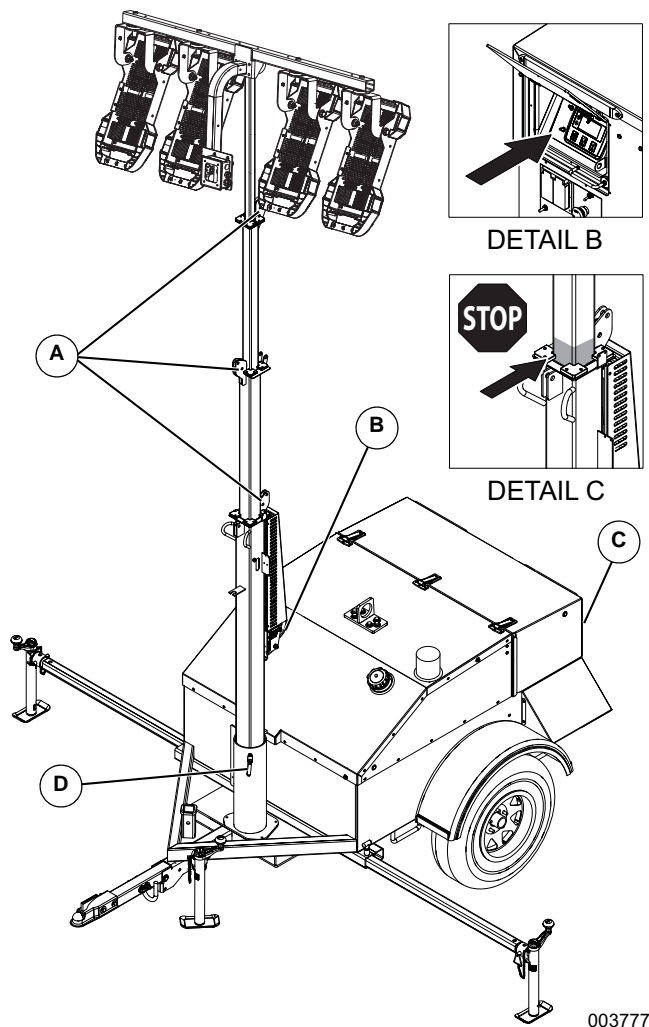

003777

Figure 3-4. Switch & Pulley Locations - Electric Winch

Preparing for Start-Up

NOTE: If the engine was run out of fuel or the fuel tank was drained, it may be necessary to bleed the fuel lines before starting. Refer to the engine manual supplied with the unit.

NOTE: On initial start-up, or if the engine was run out of fuel, it may be necessary to cycle the diesel fired block heater for a few minutes. before starting. See *Diesel Fired Block Heater (if equipped)* in Section 2.

Select AUTO Mode or MANUAL Mode

See *Figure 3-5*. Using the arrows on the PowerZone–DLA, select either AUTO or MANUAL on the Home screen.

- AUTO mode is required for programming automatic start and stop times (see *Scheduler Screen*), or enabling the “Night Watchman” sensor (see *Dusk to Dawn Screen*.)
- MANUAL mode is used for on-demand control of the lights and convenience outlets.

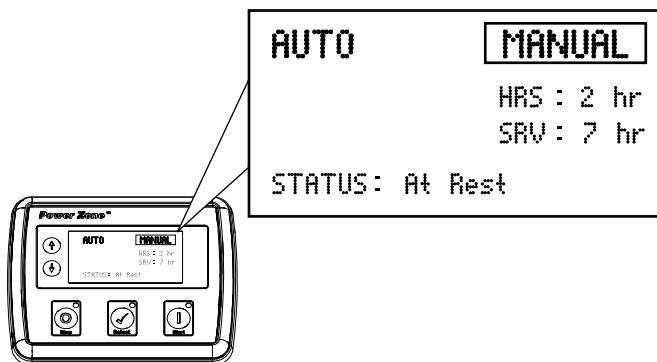

Figure 3-5. Selecting MANUAL or AUTO Mode

Configure for Intended Use

As described in “General Information”, the engine in this unit runs at low speed when the LED lights are operating and no loads are connected to the 120 or 240V convenience outlets. The engine runs at high speed when the LED lights are turned off. Therefore, before starting, determine if auxiliary equipment will be connected to the convenience outlets. Then set up the unit based on the intended use:

LED Lights Only

Turn the 240V outlet breaker OFF. The engine will run at low speed while operating, greatly reducing sound emissions and fuel consumption.

LED Lights and Export Power

Turn the 240V outlet breaker ON and Load Sense OFF. The engine will run at high speed for powering high amperage equipment.

LED Lights and Export Power with Load Sense

Turn the 240V outlet breaker ON and Load Sense ON. The engine will run at high speed when detecting applied load(s) such as hand tools and low amperage equipment.

Table 3-1 illustrates the four possible combinations of 240V outlet breaker and Load Sense switch positions.

		Load Sense Switch	
		ON (I)	OFF (O)
240VAC Outlet Breaker	ON (i)	Load dependent—variable speed*	High speed 1800 rpm
	OFF (O)	Low speed	Low speed 1350 rpm
<i>*Engine will speed up automatically when more power is drawn from receptacles.</i>			

Start Sequences

The following pages contain flowchart diagrams of the start sequences for standard units and those equipped with diesel fired block heaters.

Start Sequence—Standard Units

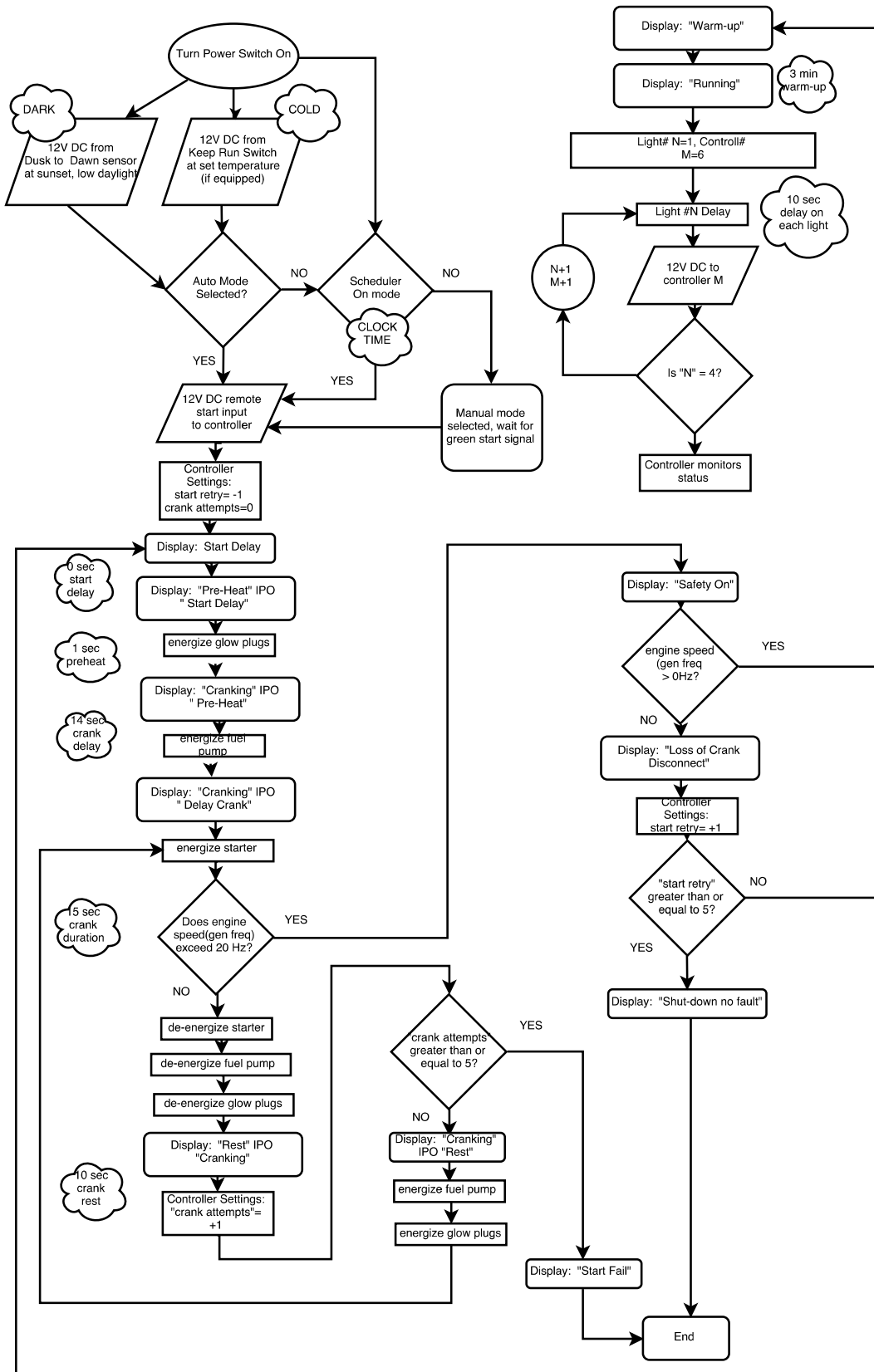

Start Sequence—Units with Diesel Fired Block Heaters

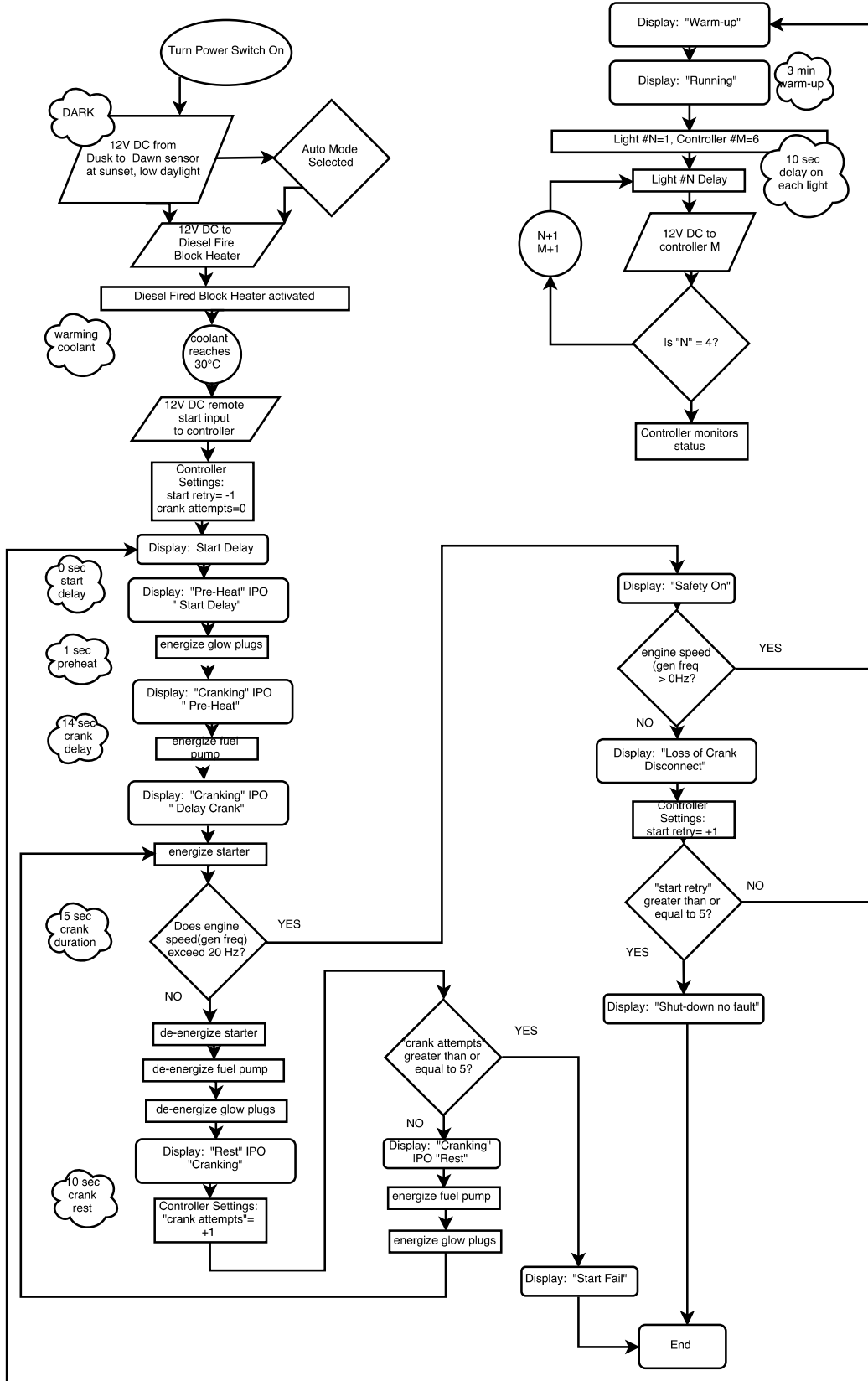

Manually Starting the Unit In Low Speed

STOP mode is the default start-up setting for all units equipped with the PowerZone–DLA. Use the following procedure to start the generator in MANUAL mode.

1. Check that the 240VAC outlet breaker is in the OFF (O) position.
2. Move the Control Power switch to the ON (I) position.
3. Verify that the Load Sense switch is OFF.
4. When the controller powers up, the Home screen displays on the LCD screen and the Stop LED illuminates to indicate that the controller is in STOP mode. Press the Start button to initiate the startup procedure. Assuming there are no existing engine faults, the engine will start and the Start LED will illuminate.

NOTE: The engine can be started from any screen. It may take a few seconds for the engine to run smoothly and reach its governed operating speed.

5. If the engine does not start after the first cranking attempt, the engine will pause for 15 seconds to allow the starter to cool. The controller backlight will go out. The engine will make two more attempts to start for a total of three crank cycles.

NOTE: UR units only—engine will attempt five crank cycles.

6. If the engine does not start and run within three starting cycles, the LCD screen will display the “Fail to Start” alarm. The starting sequence can be repeated after the starter cools for at least two minutes. Pressing the Stop (O) button will clear the alarm and reset the controller.
7. The engine may hunt or change speeds until low operating speed (1350 rpm) is reached. After a few minutes at operating speed, the Home screen will display the mode of the unit, the engine status, the engine RPM, and any active program (Scheduler or Dawn to Dusk) in AUTO mode.
8. Check the generator for excessive noise or vibration and any leaking coolant, oil, or fuel before applying loads.
9. Once the engine is running, turn ON (I) both the outlet breaker and Load Sense Switch to allow engine to run at high speed when load is applied to the unit.

Manually Starting the Unit In High Speed

At ambient temperatures below 30°F (-1°C), it may be desirable to start at high speed to reduce crank attempts.

1. Switch the 240VAC outlet breaker to the ON (I) position.
2. Follow steps 2 through 6 from [Start Sequences](#).

Light Operation

See [Figure 3-6](#). The lights are turned on and off using the PowerZone–DLA. To view the light screen, press the ↑ button three times from the Home screen.

NOTE: The lights can only be turned on and off while the unit is running in MANUAL mode. They operate automatically in AUTO mode.

1. Once the engine is up to temperature and running smoothly, switch the main circuit breaker to the ON (I) position.

To turn the light(s) on, press the Select (✓) button. To turn the light(s) off, press the Select (✓) button.

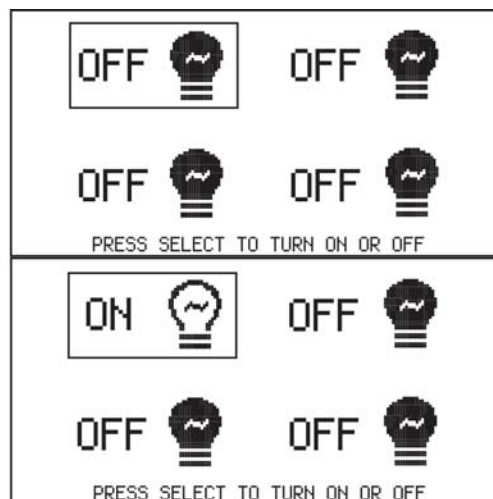

002383

Figure 3-6. Lights Screen

Engine Derating

All units are affected by derating for altitude and temperature. Derating reduces the available power for operating tools and accessories connected to the receptacles. Typical reductions in performance are 2-4% for every 1000 ft (305 m) of elevation and 1% per 10°F (5.6°C) increase in ambient air temperature over 72°F (22°C).

Wet Stacking

The ECOSpeed engine in this unit eliminates the adverse effects of “wet stacking” caused by prolonged operation of a cold, lightly-loaded diesel engine. These include:

- fuel dilution
- sooting with heavy, black exhaust
- moisture accumulation

Engine temperature and speed are continuously managed to avoid developing a wet stack condition.

Dusk to Dawn Sensor

This unit is equipped with a “dusk to dawn” photo sensor to detect the surrounding light level, automatically starting the engine and turning the lights on at dusk. The engine will run and the lights will remain illuminated until dawn. (See [Dusk to Dawn Screen](#) in “General Information”.)

To prepare the sensor for use, perform the following procedure at the time of day you want the lights to turn on:

1. Verify the Power Zone–DLA is set up and the unit is ON.
2. Slide the light shield bracket up, decreasing the sensor’s exposure to light, until the lights turn ON.
3. Tighten screws on shield.

Fuel Level Warning Beacon

An internal fuel level sensor detects the usable amount of fuel in the tank. When the fuel level drops to 10% or below of maximum usable fuel capacity, the fuel level warning beacon illuminates and flashes. The beacon will remain illuminated until the fuel level is raised to at least 15% of maximum usable fuel capacity.

Customer Convenience Outlets

See [Figure 3-7](#). The unit is equipped with convenience outlets for powering accessories or tools from the generator. Power is supplied to the outlets any time the engine is running and the 240VAC outlet breaker is switched to the ON (I) position. Each outlet has an individual circuit breaker, located on the control box. Refer to [Control Panel](#).

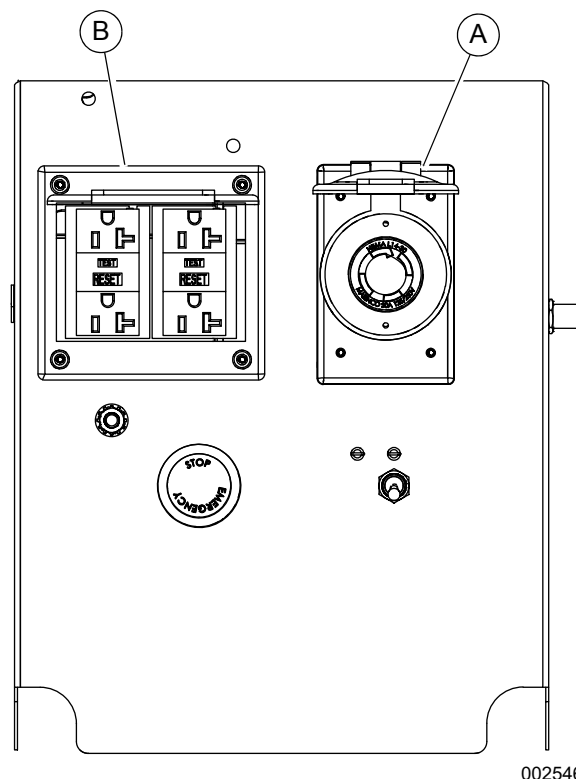

Figure 3-7. Location of Receptacles

See [Figure 3-7](#). The circuit breakers are labeled with the corresponding voltage for the receptacle they protect. The standard receptacle panel is equipped with the following receptacles:

- One 240V/30A Twist-lock (A)
(or RV receptacle, if equipped)
- Two 120V/20A GFCI (B)

With all of the lights OFF, full generator power output is available to the receptacles.

NOTE: All equipment or load panels connected to the generator **MUST** be properly grounded. If these appliances do not have grounded plugs, a ground wire **MUST** be added between the equipment and the grounding stud on the receptacle panel per the National Electrical Code (NEC), state and local regulations.

Shutting Down the Unit

Check with personnel using power supplied by the unit and let them know the power is going to be turned off. Verify the power shutdown will not create any hazards by accidentally turning off equipment that needs to remain running (pumps, compressors, lights, etc.).

1. Remove all loads from the outlets.
2. Switch the lights off using the controller.
3. Switch the outlet breaker to the OFF (O) position.
4. Press the Stop (O) button.

- After the unit shuts down, move the Control Power switch to the OFF (O) position.

NOTE: Disconnect the battery if the unit is to be stored for an extended period. Refer to the engine operator's manual for additional extended storage procedures.

Automatic Shutdown

This unit is equipped with a low oil pressure and high coolant temperature automatic shutdown system. This system will automatically shut off the fuel supply to stop the engine if oil pressure drops too low or the engine exceeds normal operating temperature. Return the Control Power switch to the STOP position to reset the unit after the cause of shutdown has been determined.

Emergency Stop



Equipment Damage. The emergency stop switch is not to be used to power down the unit under normal operating circumstances. Doing so will result in equipment damage. (000246)

See **Figure 3-8**. The unit is equipped with one emergency stop button, clearly labeled "EMERGENCY STOP." The button can be accessed and activated with all doors closed and locked.

Activate the emergency stop button by pushing it in until it locks down. This trips the main circuit breaker, which will open the contact and disconnect the load to the connection lugs. An emergency stop also opens the fuel circuit, shutting down the engine. The emergency stop fault will be displayed on the control panel.

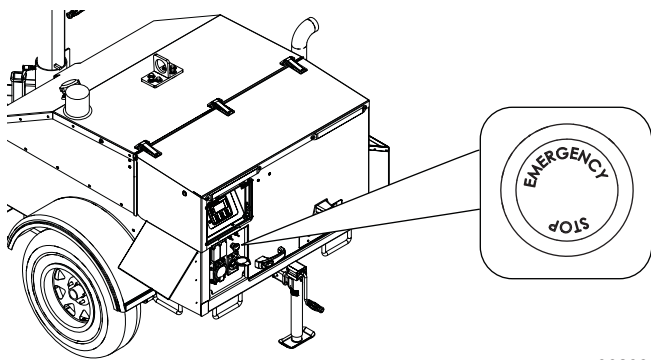

002330

Figure 3-8. Emergency Stop Switch

The emergency stop button will remain locked until it is pulled out.

NOTE: To shut down the unit under any other circumstances, refer to **Shutting Down the Unit**.

Lowering the Mast—Manual Winch

- Shut down the lights and engine. See **Shutting Down the Unit**.
- Lower the mast.
- Use the winch handles to collapse the mast to its lowest position. Verify that the electrical cord does not get caught in, or pinched by, the mast while it is being lowered.



Personal Injury. Stop immediately if the mast hangs up or the winch cable develops slack. Excess slack could cause the mast to collapse, resulting in personal injury or equipment damage. (000265)

IMPORTANT NOTE: Contact an ASD immediately if the mast hangs up or the winch cable develops slack.

- See **Figure 3-9**. If the unit is going to be moved, rotate the mast so the lights face the rear of the unit.

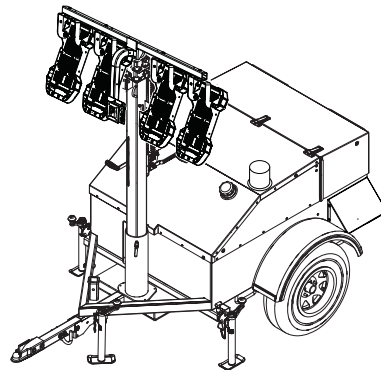

003785

Figure 3-9. Stowed (Travel) Position

To rotate the mast:

- Loosen the mast rotation knob.
- Rotate the mast until the white arrows are aligned and the metal stop tabs are touching.
- Tighten the mast rotation knob.

Lowering the Mast—Electric Winch (if equipped)

Electrically Lowering the Mast

1. Shut down the lights and engine. See [Shutting Down the Unit](#).
2. Press and hold the winch control switch downward to collapse the mast to its lowest position. Verify the electrical cord does not get caught in, or pinched by, the mast while it is being lowered.
3. If the unit is going to be moved, rotate the mast so the lights face the rear of the unit. To rotate the mast:
 - a. Loosen the mast rotation knob.
 - b. Rotate the mast until the white arrows are aligned and the metal stop tabs are touching.
 - c. Tighten the mast rotation knob.

WARNING

Personal Injury. Stop immediately if the mast hangs up or the winch cable develops slack. Excess slack could cause the mast to collapse, resulting in personal injury or equipment damage.

(000265)

IMPORTANT NOTE: Contact an ASD immediately if the mast hangs up or the winch cable develops slack.

NOTE: If the generator is not operational, and the batteries do not have enough power to lower the mast, it may be necessary to lower the mast manually.

Manually Lowering the Mast

IMPORTANT NOTE: Do not use this procedure unless it is absolutely necessary. Frequent use of this procedure could damage the motor shaft.

1. See [Figure 3-10](#). Remove the motor cover (A).

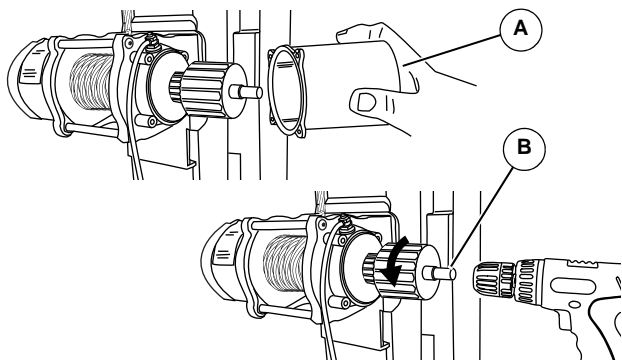

Figure 3-10. Manually Lowering the Mast

2. Attach a drill chuck firmly to the exposed motor shaft (B).
3. Using the drill, slowly rotate the motor shaft counterclockwise to lower mast.

4. Detach the drill chuck and install the motor cover after the mast is completely lowered.

Towing the Unit

Once the engine is shut down and the mast and lights are properly stowed, follow these steps to prepare the unit for towing.

1. Raise the outrigger jacks completely and release the locking pins to rotate them up into the travel position. Make sure the locking pins snap into place. Release the outrigger locking pins and slide the outriggers into the trailer frame until the locking pins snap into place.
2. Use the tongue jack to raise or lower the trailer onto the hitch of the towing vehicle. Lock the hitch coupling and attach the safety chains or cables to the vehicle. Remove the tongue jack locking pin and rotate the jack into the travel position. Replace the locking pin.
3. To ensure proper operation of the jacks, lubricate the grease fittings located on the leveling jacks. Refer to [Jack Maintenance](#). For maintenance interval information, refer to [Table 4-1](#).
4. Connect any trailer wiring to the tow vehicle. Check for proper operation of the directional and brake lights.
5. Verify the enclosure is properly latched.
6. Check for proper inflation of the trailer tires. For maximum tire pressures, refer to [Specifications](#).
7. See [Figure 3-11](#). Check the wheel lugs. Tighten or replace any lugs that are loose or missing. If a tire has been removed for axle service or replaced, tighten the lugs, in the order shown, to the following specifications:

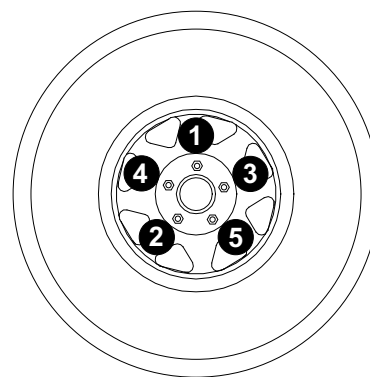

Figure 3-11. Tightening Wheel Lugs

- a. Start all lug nuts by hand.
- b. First pass: tighten to 20-25 ft-lbs (27-33 Nm).
- c. Second pass: tighten to 50-60 ft-lbs (67-81 Nm).
- d. Third pass: tighten to 90-120 ft-lbs (122-162 Nm).

NOTE: After the first road use, re-torque the lug nuts in sequence.

Maximum recommended speed for highway towing is 45 mph (72 km/h). Recommended off-road towing speed is not to exceed 10 mph (16 km/h) or less, depending on the terrain.

Tandem Tow

See [Figure 3-12](#). The tandem tow hitch (A) allows the operator to tow a second MLT4060MVD Light Tower in series behind the unit. See [Tandem Towing Safety](#) in Section 1 for more information.

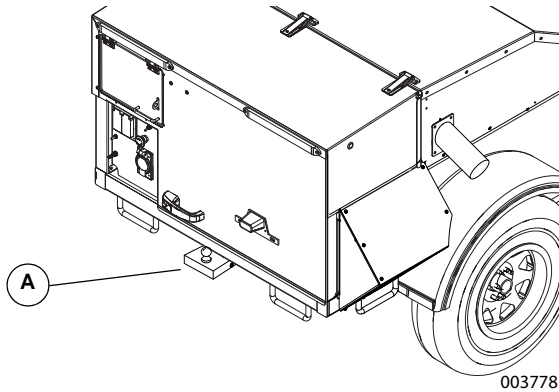

Figure 3-12. Tandem Tow Hitch

Tying the Unit Down

When securing the unit for transportation, verify the equipment being used to fasten the unit is in good condition and has sufficient strength to hold the unit in place during transport.

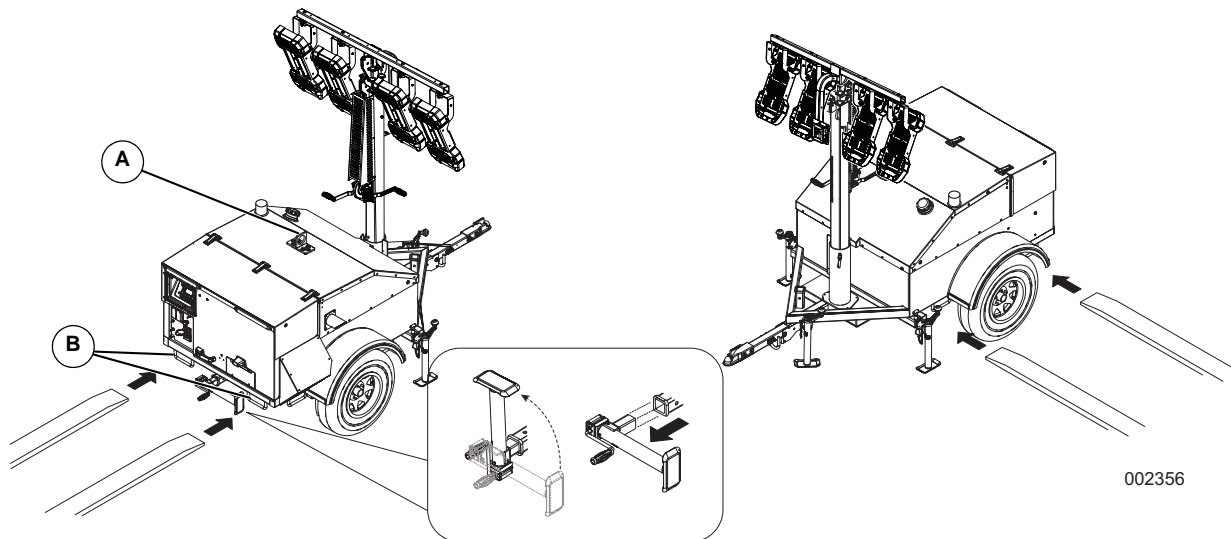
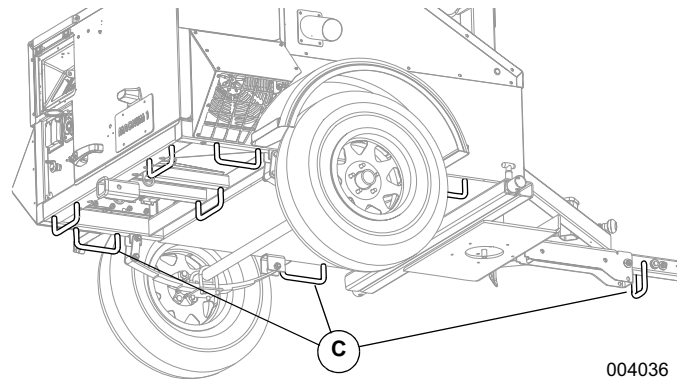

Figure 3-14. Lift Points

See [Figure 3-13](#). Use the tie-down points (C) as shown.



004036

Figure 3-13. Tie-Down Points

Lifting the Unit

Follow these steps to prepare the unit for lifting:

1. Verify the equipment being used to lift the unit is in good condition and has sufficient capacity. For approximate weights, refer to [Specifications](#).
2. Close and lock all hoods and doors.
3. See [Figure 3-14](#). Stow the mast and lights in the travel position as shown.
4. Always remain aware of people and objects around the unit while preparing, maneuvering, and lifting the unit.
 - When lifting the unit, attach any slings, chains or hooks directly to the central lift point (A).
 - Use the forklift pockets (B) with care. Lift only from the side or the rear. Avoid approaching the unit at

Section 4: Maintenance

Emissions Information

For warranty information, please refer to the diesel engine manual supplied with this unit.

Daily Walk-Around Inspection

Perform a walk-around inspection of the unit every day before starting the unit. Look for conditions that could hinder performance or safety, such as (but not limited to):

- Oil, coolant and fuel leakage
- Standing water inside the cabinet
- Blocked vents
- Loose or missing hardware
- Loose or broken electrical connections.

Inspect the fan belt for cracks, fraying, or stretching. Verify the belt is properly seated in the pulley grooves. Replace the belt according to the manufacturer's recommendations.



Equipment Damage. Failure to perform a daily inspection could result in damage to the unit.

(000306)

General Maintenance

Poorly maintained equipment can become a safety hazard. In order for the equipment to operate safely and properly over a long period of time, periodic maintenance and occasional repairs are necessary. **DO NOT** perform routine service (oil and filter changes, cleaning, etc.) unless all electrical components are shut off.

Regular maintenance will improve performance and extend engine/equipment life. Generac Mobile Products LLC recommends that all maintenance work be performed by a Generac Mobile Products Authorized Service Dealer (ASD). Regular maintenance, replacement or repair of the emissions control devices and systems may be performed by any repair shop or person of the owner's choosing. However, to obtain emissions control warranty service free of charge, the work must be performed by an ASD or authorized Mitsubishi engine dealer depending on the repair. See the emissions warranty.

Preparing for Service

Before servicing the unit, always follow the instructions listed below.

1. Verify the Control Power switch is OFF.
2. Verify the circuit breakers are OFF.
3. Disconnect the negative (-) terminal on the battery.
4. Attach a "Do Not Start" sign to the control panel. This will notify everyone that the unit is being serviced and will reduce the chance of someone inadvertently trying to start the unit.

Cleaning the Unit

Always clean the Light Tower after each use to remove dust, grease, mud, or spilled fuel or oil. Use soft, clean rags to wipe the cabinet exterior and control panel. Low-pressure compressed air (less than 40 PSI [276 kPa]) can also be used to remove dust and debris from the cabinet interior.

This unit contains sensitive electronic components that can be damaged by high pressure and heat. Therefore:

- Do not wash the unit with a high pressure hose or power washer.
- Do not wash the engine block or fuel tank with a power washer or steam cleaner. Water may enter the cabinet and collect in the generator windings or other electrical parts, causing damage.

Inspecting the Unit

- If the unit is stored outside, check for water inside the cabinet and generator before each use. If wet, dry the unit thoroughly before starting.
- Inspect condition of electrical cords. **DO NOT** use the unit if insulation is cut or worn through.
- Verify winch cables are in good condition and centered on each pulley. **DO NOT** use a cable that is kinked or starting to unravel.
- Verify the safety pins for the mast lock rod and mast lock bar are present and secured with a chain. Check that the spring located in the mast lock bar is not broken or missing. Check the operation of the mast lock bar.
- Verify the wheel lugs are present and properly tightened. Refer to [Towing Safety](#).
- Check the coolant level daily by inspecting the level in coolant overflow jug located near the radiator. Refer to the engine operator's manual for coolant recommendations and proper mixture. Normal operating level is between the 'full' and 'add' markings on the overflow jug.

- **AFTER ENGINE IS STOPPED AND COMPLETELY COOL**, coolant may be added directly to the coolant overflow jug.
 - Check the oil level daily. Refer to the engine operator’s manual for the appropriate oil specification. Make sure that the oil is correct for special operating conditions such as a change in season or climate.
 - **DO NOT** start the unit if the engine oil level is below the add mark on the dipstick.
 - Normal operating level is in the cross-hatch pattern between the full and add markings on the dipstick.
 - Add oil only if the oil level is below the add mark on the bottom of the cross-hatch pattern on the dipstick. **DO NOT OVERFILL** the crankcase.
 - Check the fuel level.
 - If the unit is connected to a remote start or transfer switch, make sure the remote switch is also off and tagged.
- NOTE:** If the engine was run out of fuel or the fuel tank was drained, it may be necessary to bleed the fuel lines. Refer to the engine operator’s manual supplied with the unit.

Table 4-1. Basic Maintenance Schedule

Item	Daily	750 Hours	As Required
Perform a daily walk-around inspection; see <i>Inspecting the Unit</i>	◆		
Check Oil Level	◆		
Check Coolant Level	◆		
Check Fuel Level	◆		
Check Tire Pressure	◆		
Check All Electrical Connections	◆		
Inspect Radiator Fins For Debris, Clean As Required	◆		
Inspect Light Tower Winch For Proper Operation	◆		
Replace Engine Oil and Oil Filter		◆*†	
Belt And Belt Tension— Inspect, Adjust, and Replace if Necessary		◆*	
Replace Fuel Filter		◆	
Check Battery Condition		◆	
Replace Air Cleaner Element		◆	
Lubricate Leveling Jacks			◆
Fuel System— Bleed Air			◆
Drain Residual Water From Fuel Filter			◆

* Perform after the initial 50 hours of operation ONLY, then on the regularly scheduled interval as indicated in the table above.

† Generac Mobile Products recommends that oil change intervals on the ECOSpeed engine be extended to 750 hours after initial break-in. The engine comes from the factory with a larger sump that holds 5.5 quarts (5.2 L) of engine oil. After the initial 50 hour break-in and oil change, the sump, coupled with the larger oil filter (P/N 70124), allows the engine to operate up to 750 hours between routine oil changes.

Hot, humid or dusty conditions can shorten engine oil service life, regardless of suggested oil change intervals. In extreme conditions, determine oil life and change intervals through regular oil sampling and analysis.

Always follow the recommendations of the OEM engine manual that was shipped with the unit for specific operating instructions. If further technical assistance is required, contact Generac Mobile Products Technical Service at 1-800-926-9768.

Resetting the Maintenance Alarms

The Power Zone–DLA will display a warning message when the unit is due for maintenance or service. The maintenance or service interval is set at 750 hours of engine running time. Once the unit has been serviced, the appropriate maintenance alarm reminder needs to be reset. The following procedure demonstrates how to reset the maintenance alarms:

1. With the unit shut down, move the control power switch to the ON (I) position. After initialization, the controller will toggle automatically to the Home screen.
2. Press \uparrow and \downarrow simultaneously to enter the navigation menu.
3. See Press \uparrow or \downarrow to move to the top of the screen. Press \checkmark to enter the Maintenance screen.
4. Press \uparrow or \downarrow to highlight the desired alarm that needs to be reset. Press \checkmark to start reset.
5. Enter the pin 4444. To do this, press \checkmark and then \uparrow or \downarrow to adjust the first number of the maintenance pin. Press \checkmark to continue to the next number.

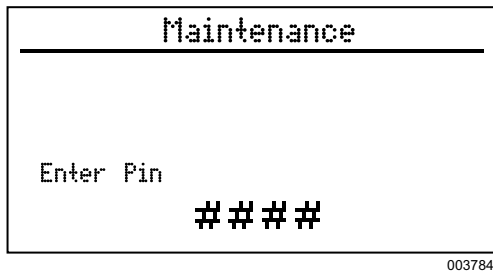

Figure 4-1. Entering Maintenance Pin

Winch Use, Operation and Maintenance—Manual

Prior to Use

- Inspect rope or cable and replace if damaged.
- Check mounting hardware for proper tightness and re-torque if necessary.
- Gears, ratchet pivot point and shaft bushings must be kept lubricated with a thin film of oil or grease.

Operation

Raising the Lights:

1. The cable must be securely fastened to the object being lifted and to the winch drum.
2. Verify the cable and cable attachments are not damaged. Contact Generac Mobile Products to order a replacement cable if necessary.
3. Referring to the “Lift / Let Down” decal on the winch, turn handle according to the specified direction to lift. The ratchet **MUST** make a loud clicking sound while winding the cable.

Lowering the Lights:

Referring to the “Lift / Let Down” decal on the winch, turn handle according to the specified direction to lower. No clicking will be heard because the brake system is activated.

Maintenance

The following procedures should be performed at least annually:

1. The gears and bushings of the winch must be kept lubricated. Apply a thin film of grease to the gear teeth, and oil the bushings as needed.
2. The ratchet pawl pivot point must be kept lubricated with a thin oil.

NOTE: Do not get oil or grease on the brake mechanism.

Winch Use, Operation and Maintenance—Electric

- Keep the winch free of dirt, oil, grease, water and other substances.
- Check all mounting bolts and verify they are tightened to the recommended torque values. Replace any damaged fasteners.
- Periodically check all connections to verify they are tight and free of corrosion.
- Check the cable for visible damage every time the winch is operated. Examples of damage are: cuts, knots, crushed or frayed portions, and broken strands. Replace cable immediately if damaged. Failure to replace a damaged cable could result in breakage.
- Regularly check the brake for slippage or drift. This is detected visually when winch is under load. If winch drum continues to turn after controls are released, the brake may need to be replaced.

- Periodically clean and grease the brake assembly. This will ensure proper performance and extend the life of the winch. If winch seems to labor or get excessively hot during the lowering of loads, the brake will need to be serviced or replaced.
- Check motor brushes periodically and replace when necessary.

NOTE: Only the motor brushes and brake assembly require periodic replacement.

Winch Mechanical Brake

The mechanical brake generates heat when loads are lowered and the wire cable is powered out. Care must be taken to avoid overheating the mechanical brake.

Whine or chatter associated with a new mechanical brake is normal and typically disappears with use.

Overheating the mechanical brake may result in permanent damage to, or failure of, the brake. Replace any damaged brake components before resuming use of the winch.

Table 4-2. Winch Preventive Maintenance Schedule

Maintenance Activity	After First Operation	Before Each Use	Semi-Annually
Check Fasteners	◆		◆
Check Electrical Connections	◆		◆
Check Condition of Cables		◆	
Clean And Grease Brake Assembly			◆
Check Motor Brushes			◆
Visually Check Winch And Control	◆	◆	◆

Jack Maintenance

Before each use, check each jack foot for damage and remove any mud or debris. The jacks must be clean and in good operating condition to properly support the unit.

Trailer Wheel Bearings

The trailer axles are equipped with grease fittings to allow lubrication of the wheel bearings without the need to disassemble the axle hub. Use only a high quality grease made specifically for lubrication of wheel bearings, such as Valvoline W615 or equivalent.

See [Figure 4-2](#). To lubricate the wheel bearings:

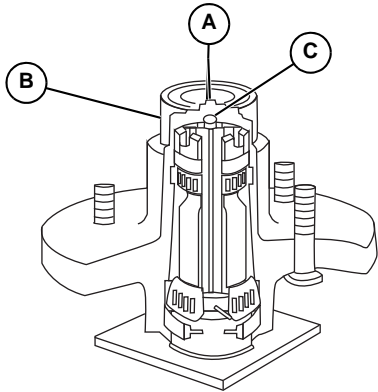

002540

Figure 4-2. Wheel Bearing Cross Section

1. Remove the small rubber plug (A) from the metal end cap (B).
2. Attach a standard grease gun fitting to the grease fitting (C).
3. Pump grease into the fitting until fresh grease is visible around the nozzle of the grease gun.
4. Wipe any excess grease from the axle hub with a clean cloth and replace the rubber plug.

The minimum recommended lubrication is every 12 months or 12,000 miles (19,312 km). More frequent lubrication may be required under extremely dusty or damp operating conditions.

Every six months, or depending on usage, check for play in each bearing by jacking up the trailer, then trying to rock the wheel. If further assistance is required, contact Generac Mobile Products Technical Service at 1-800-926-9768.

This page intentionally left blank.

Section 5: General Troubleshooting

**WARNING**

Risk of burns. Allow engine to cool before draining oil or coolant. Failure to do so could result in death or serious injury.

(000139)

**WARNING**

Electrocution. Potentially lethal voltages are generated by this equipment. Render the equipment safe before attempting repairs or maintenance. Failure to do so could result in death or serious injury.

(000187)

WARNING

Only qualified service personnel may install, operate, and maintain this equipment. Failure to follow proper installation requirements could result in death, serious injury, and damage to equipment or property. (000182)

Some of the more common problems are listed in [Table 5-1](#). This information is intended to be a check or verification that simple causes can be located and fixed. It does not cover all types of problems. Refer to the OEM engine operator's manual for additional troubleshooting information. Procedures that require in-depth knowledge or skills should be referred to an ASD.

Table 5-1. General Troubleshooting Guide

Problem	Possible Cause	Solution
Unit cranks, but will not start	Fuel level low.	Check fuel level in tank.
	Fuel flow obstructed.	Check fuel pump operation.
		Inspect fuel supply hose from tank to fuel filter for cracks and abrasion.
		Check for gelled fuel in fuel system in cold weather, especially at fuel filter.
	Air in fuel system.	Bleed air from fuel system.
	Restricted air filter.	Inspect air filter for blockage.
	Glow plug(s) inoperable.	Refer to OEM engine operator's manual for additional information.
Unit starts, but stumbles and dies	Ambient temperature too low.	Check if ambient temperature is within unit limits.
	Intake heater inoperable.	Check engine air inlet heater functionality.
High coolant temperature shutdown	Low coolant level.	Allow engine to cool, then check coolant level in radiator. Add coolant if needed.
	Blockage in radiator.	Inspect radiator surroundings for blockage and remove any foreign matter.
	Debris on radiator face.	
	Broken coolant pump belt.	Inspect for visible leaks. Check tension of water pump drive belt.
	Cooling fan inoperable.	Remove load on generator and restart engine.
Check coolant temperature and shut engine down immediately if it starts to overheat.		
Low oil pressure shutdown	Oil level low.	Check oil level. Add oil if necessary.
	Oil pump inoperable.	Contact an ASD.
Unit stalls when export power is used	Load exceeds unit rating.	Turn outlet breaker ON and load sense switch OFF, confirm generator output is 60hz + or - 2hz. Reapply load.
One or more lights do not turn on	Light breaker tripped.	Check light breakers.
	Lights not turned on.	Check electronic control to see if lights are on. Turn lights on.
The lights are flashing	Dusk-to-dawn sensor adjustment needed.	Adjust the dusk-to-dawn sensor according to <i>Dusk to Dawn Sensor</i> .
	Generator frequency too low.	Check if AC frequency is >40hz.

If problems persist, contact Generac Mobile Products at 1-800-926-9768 for assistance.

Section 6: Electrical Drawings

Wiring Diagrams

Legend / Components Located on Engine

GROUP G

LEGEND		
3OAR - 30 AMP RECEPTACLE	GS - GROUND STUD	PAS - POSITIVE AIR SHUTDOWN
ACC - ACCESSORY CONNECTOR	HFF - HEATED FUEL FILTER	PASR - PAS RELAY
ACT - ALTERNATOR CURRENT TRANSFORMER	HLLS - HIGH/LOW LOAD SWITCH	PH - PRE-START HORN
AHC - ACCESSORY HARNESS CONNECTOR	IH_ - INTAKE HEATER	PS - POWER SWITCH
ALT - DC CHARGE ALTERNATOR	IHFS - INTAKE HEAT/FAN SWITCH	R - RESISTOR
APS - ATMOSPHERIC PRESSURE SENSOR	IHR - INTAKE HEATER RELAY	R_ - RELAY
ATB - ALTERNATOR TERMINAL BLOCK	KRS - KEEP RUN SWITCH	RTMR_ - REAR TERMINAL MINI FUSE & RELAY PANEL
AVR - AUTOMATIC VOLTAGE REGULATOR	LB - LIGHT BREAKER	STR - STARTER
BATT - BATTERY (12V)	LCCC - LED COIL-CORD CONNECTOR	STTR - STATOR
BD - BATTERY DISCONNECT	LD - LED DRIVER	TCC - TEMPERATURE CONTROL CONNECTOR
CBGB - CONTROL BOX GROUND BAR	LEBC - LED EXTENSION BOX-CONNECTOR	
CL_ - CONTROL LIGHTS	LECC - LED EXTENSION COIL-CONNECTOR	
CTS - COOLANT TEMPERATURE SWITCH	LED - LIGHT-EMITTING DIODE	
D - DIODE	LR - LED RELAY	
DCB - DC BREAKER	LRHC - LIGHTS RELAY HARNESS CONNECTOR	
EHC - ENGINE HARNESS CONNECTOR	LSC - LIGHT SIGNAL CONNECTOR	
ENG - ENGINE CONNECTOR	LSCT - LOAD SENSE CURRENT TRANSFORMER	
FAN - FAN	LSM - LOAD SENSE MODULE	
FFBH - FUEL FIRED BLOCK HEATER	LTB - LED TERMINAL BLOCK	
FLS - FUEL LEVEL SENSOR	MAB - MAIN ALTERNATOR BREAKER	
FLSC - FEMALE LIGHTS SIGNAL CONN.	MAC - MAST ACCESSORY CONNECTOR	
FLWB - FUEL LEVEL WARNING BEACON	MC - MAIN CONTROLLER	
FP_ - FUEL PUMP	MLSC - MALE LIGHTS SIGNAL CONNECTOR	
FPJ - FUEL PUMP JUMPER	MPU - MAGNETIC PICKUP	
FR - FAN RELAY	MS - MAST SWITCH	
GCR - GOVERNOR CONTROL RESISTORS	MS_ - MAST STUD	
GFCIB - GFCI BREAKER	MWC - MAST WINCH CONTACTOR	
GFCIR - GFCI RECEPTACLE	NCNOS - NORMALLY CLOSED/NORMALLY OPEN SWITCH	
GND_ - GROUND	NCS - NORMALLY CLOSED SWITCH	
GOV - GOVERNOR	NTB - NEUTRAL TERMINAL BLOCK	
GP - GLOW PLUG	NW - NIGHT WATCHMAN	
GPR - GLOW PLUG RELAY	OPS - OIL PRESSURE SWITCH	

COMPONENTS LOCATED ON ENGINE

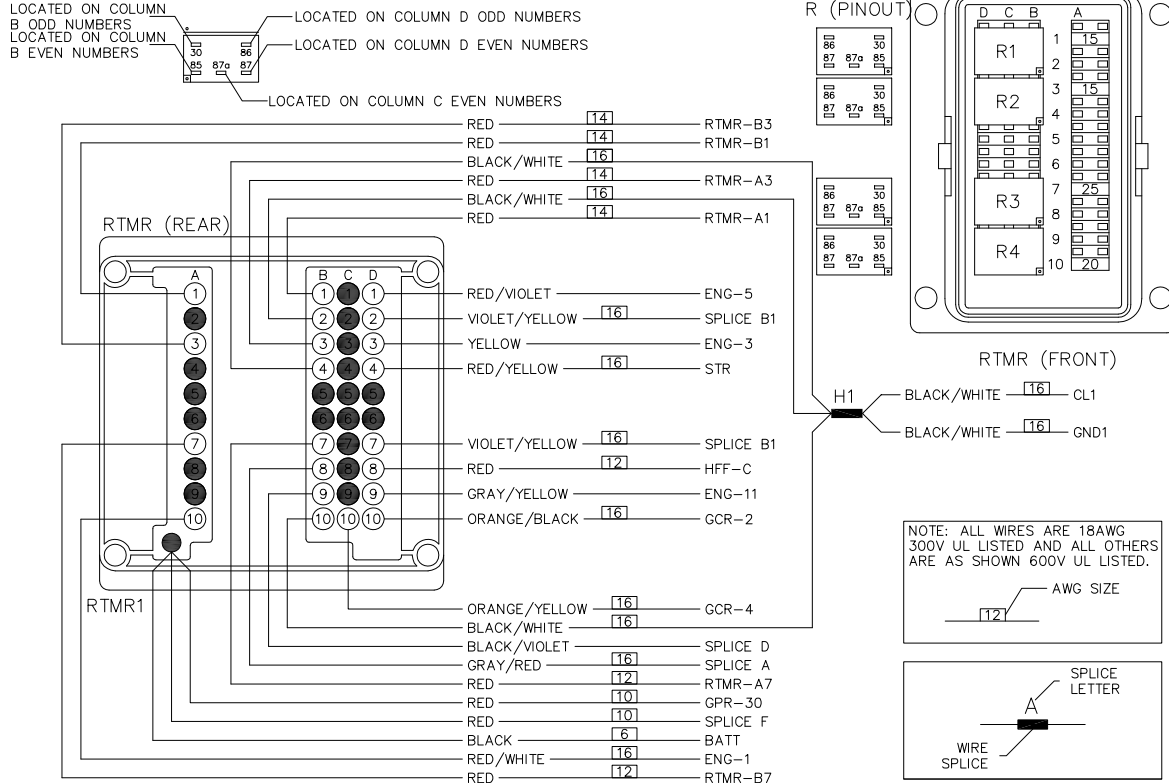

PAGE 1 OF 20

WIRING - DIAGRAM
MLT4060xVD
DRAWING #: 90681

REVISION: D
DATE: 3/28/17

PAGE 1 OF 20

Components Located on Engine (p. 2)

GROUP G

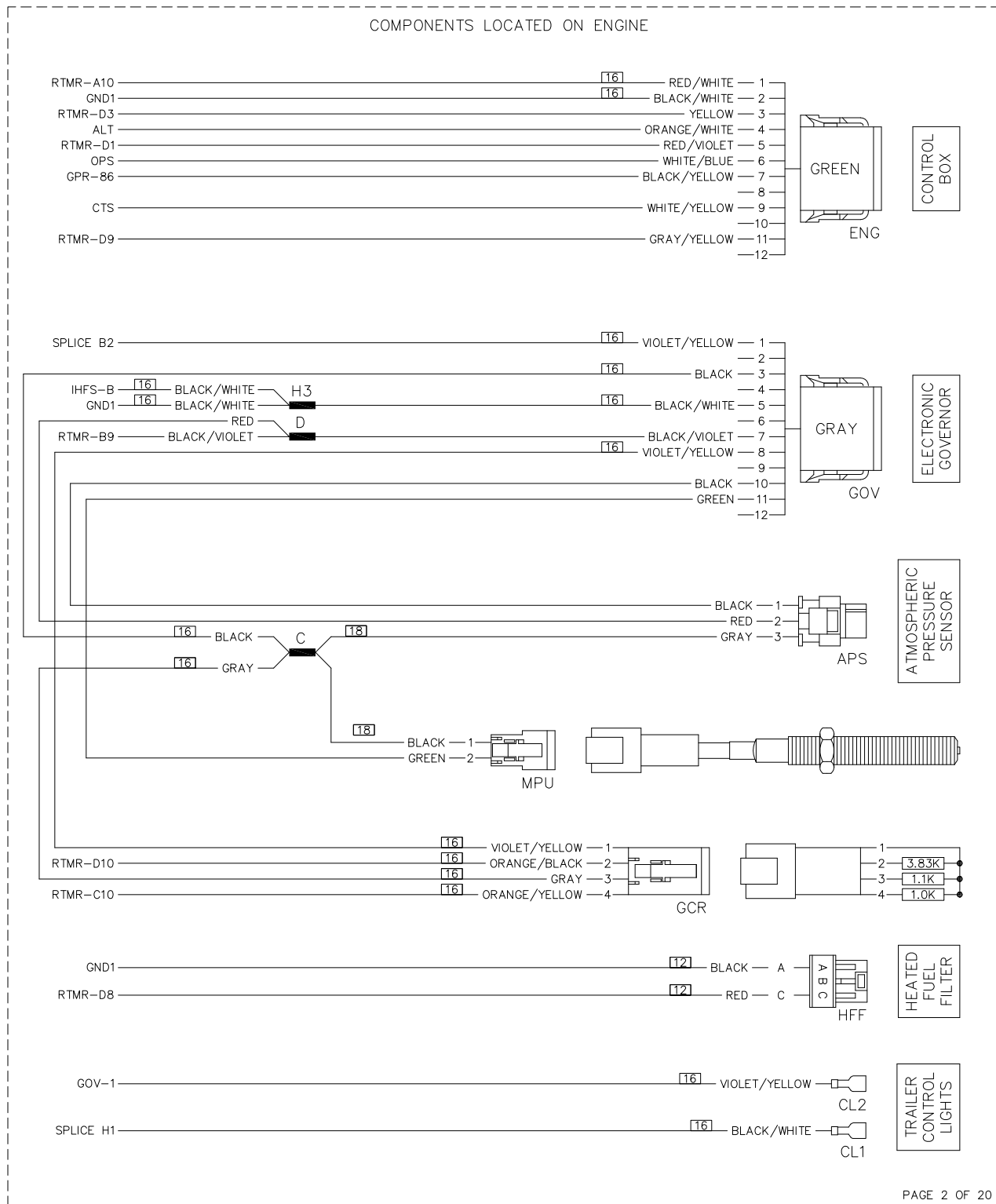

PAGE 2 OF 20

WIRING - DIAGRAM

MLT4060xVD

DRAWING #: 90681

REVISION: D
DATE: 3/28/17

PAGE 2 OF 20

Components Located on Engine (p. 3)

GROUP G

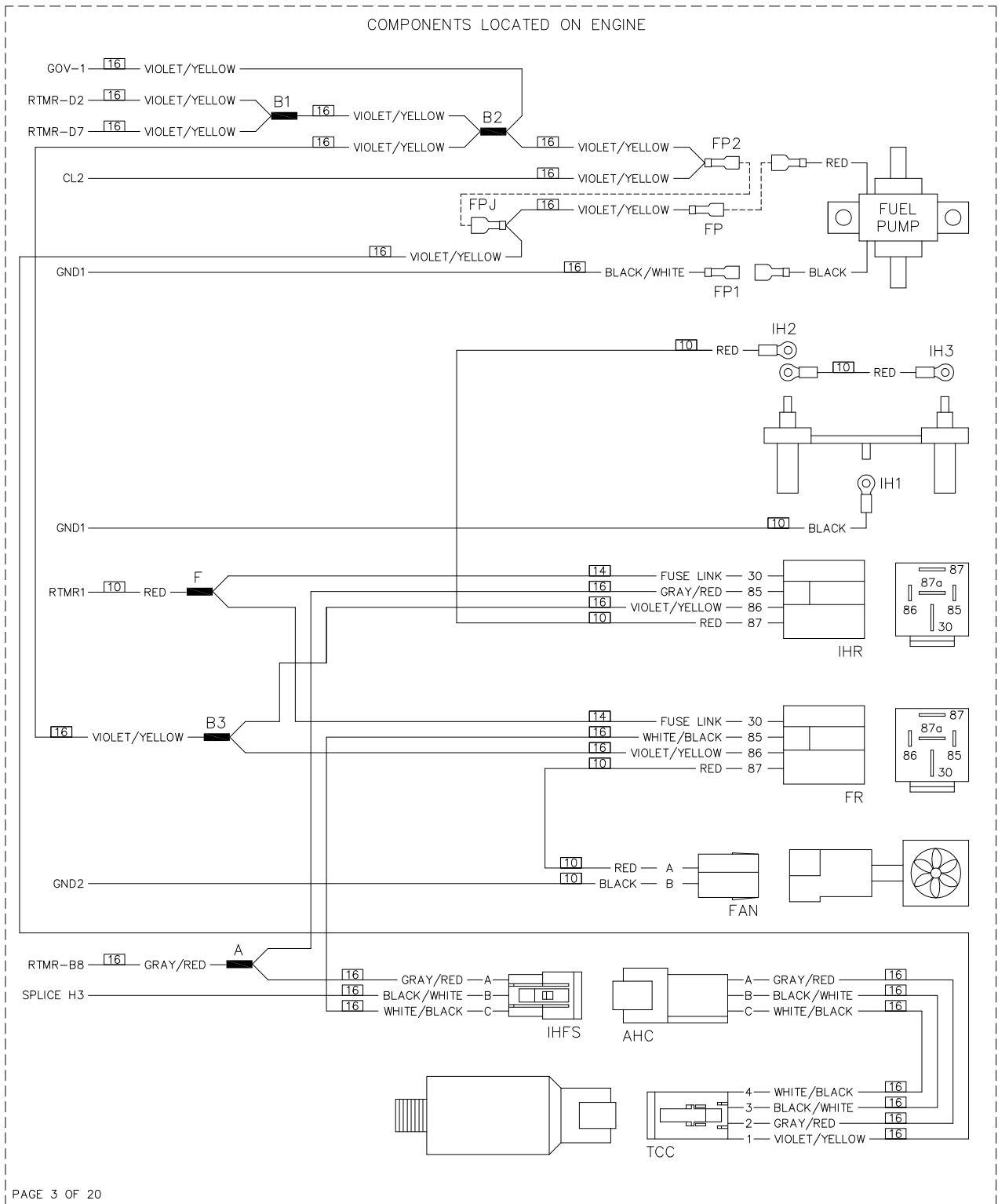

PAGE 3 OF 20

REVISION: D
DATE: 3/28/17

PAGE 3 OF 20

WIRING - DIAGRAM
MLT4060MVD
DRAWING #: 90681

Components Located on Engine (p. 4)

GROUP G

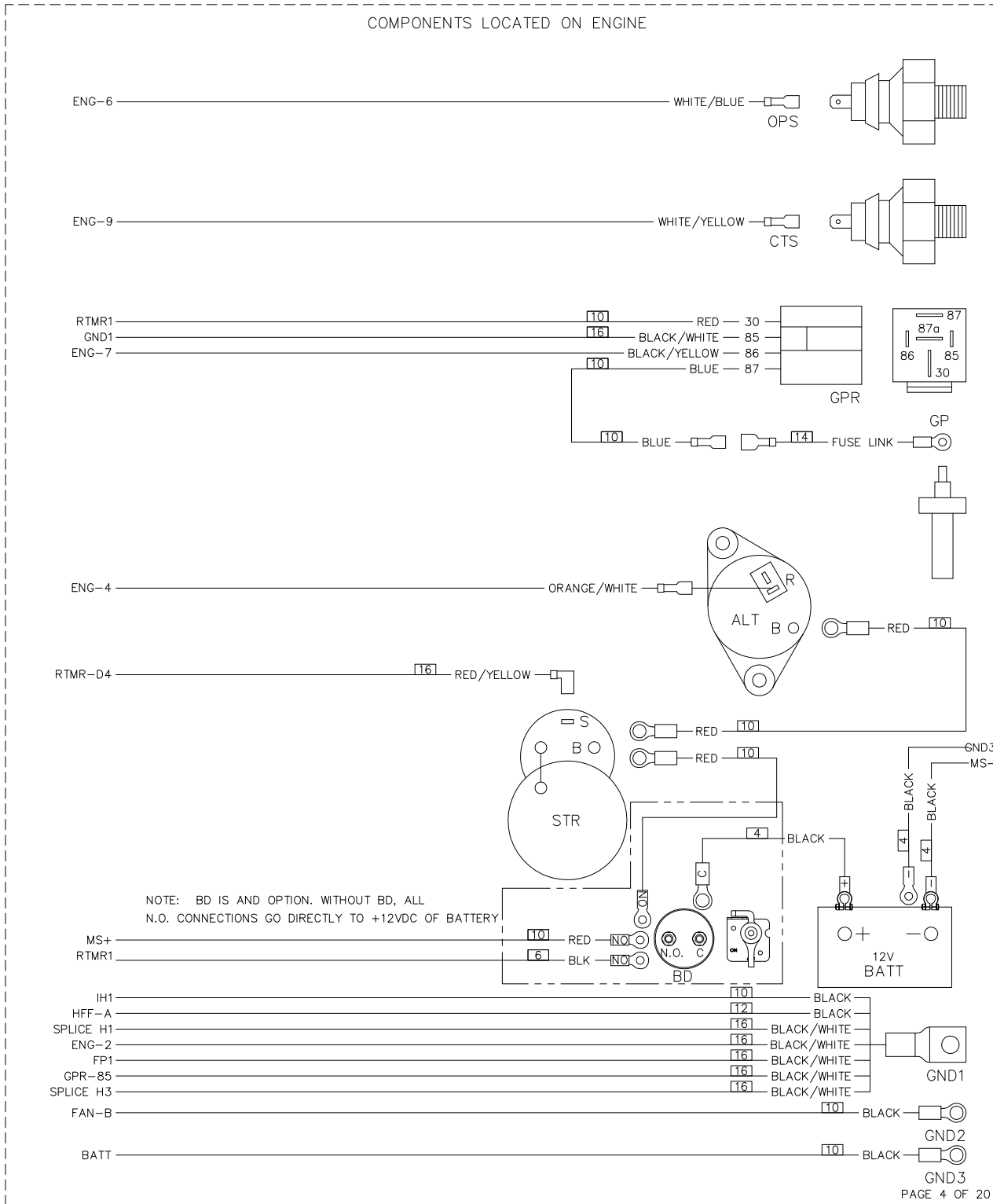

WIRING - DIAGRAM

MLT4060MVD

DRAWING #: 90681

REVISION: D
DATE: 3/28/17

PAGE 4 OF 20

Accessories (Optional)

GROUP G

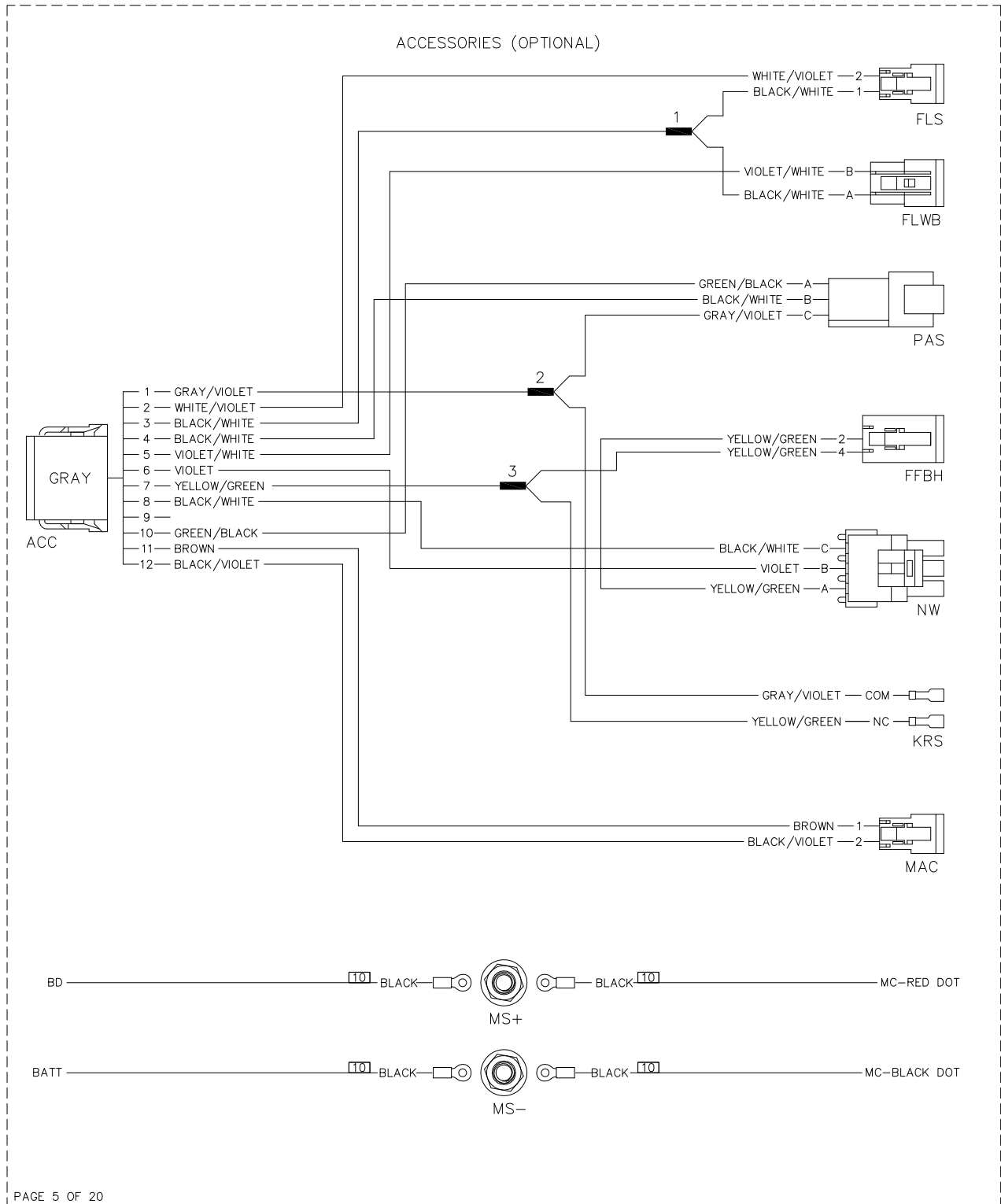

PAGE 5 OF 20

WIRING - DIAGRAM
MLT4060xVD
DRAWING #: 90681

REVISION: D
DATE: 3/28/17

PAGE 5 OF 20

Accessories (Optional) (p. 2)

GROUP G

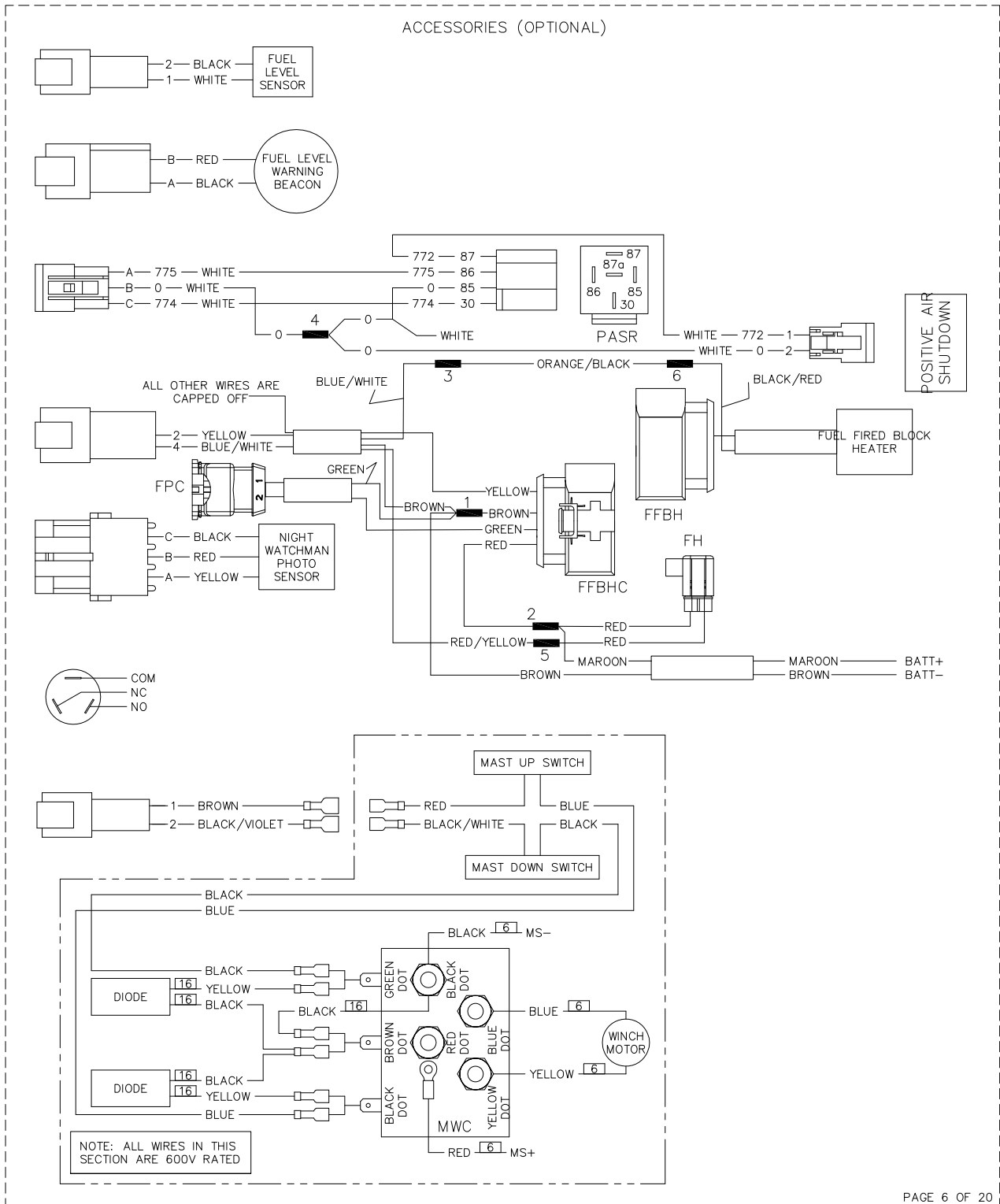

PAGE 6 OF 20

WIRING - DIAGRAM
MLT4060xVD
DRAWING #: 90681

REVISION: D
DATE: 3/28/17

PAGE 6 OF 20

DC Components in Control Panel

GROUP G

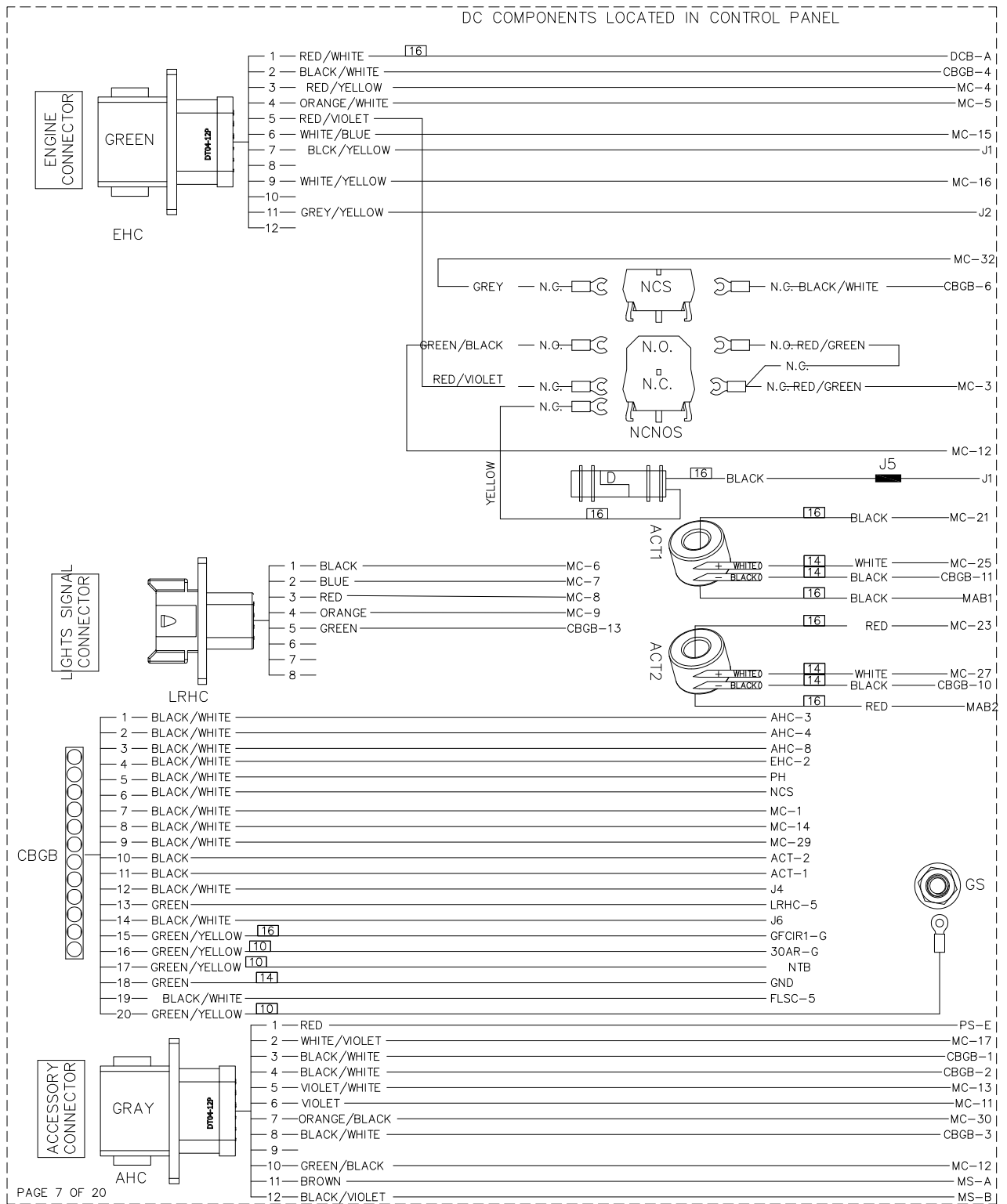

PAGE 7 OF 20

REVISION: D
DATE: 3/28/17

PAGE 7 OF 20

WIRING - DIAGRAM
MLT4060xVD
DRAWING #: 90681

AC Components in Control Panel

GROUP G

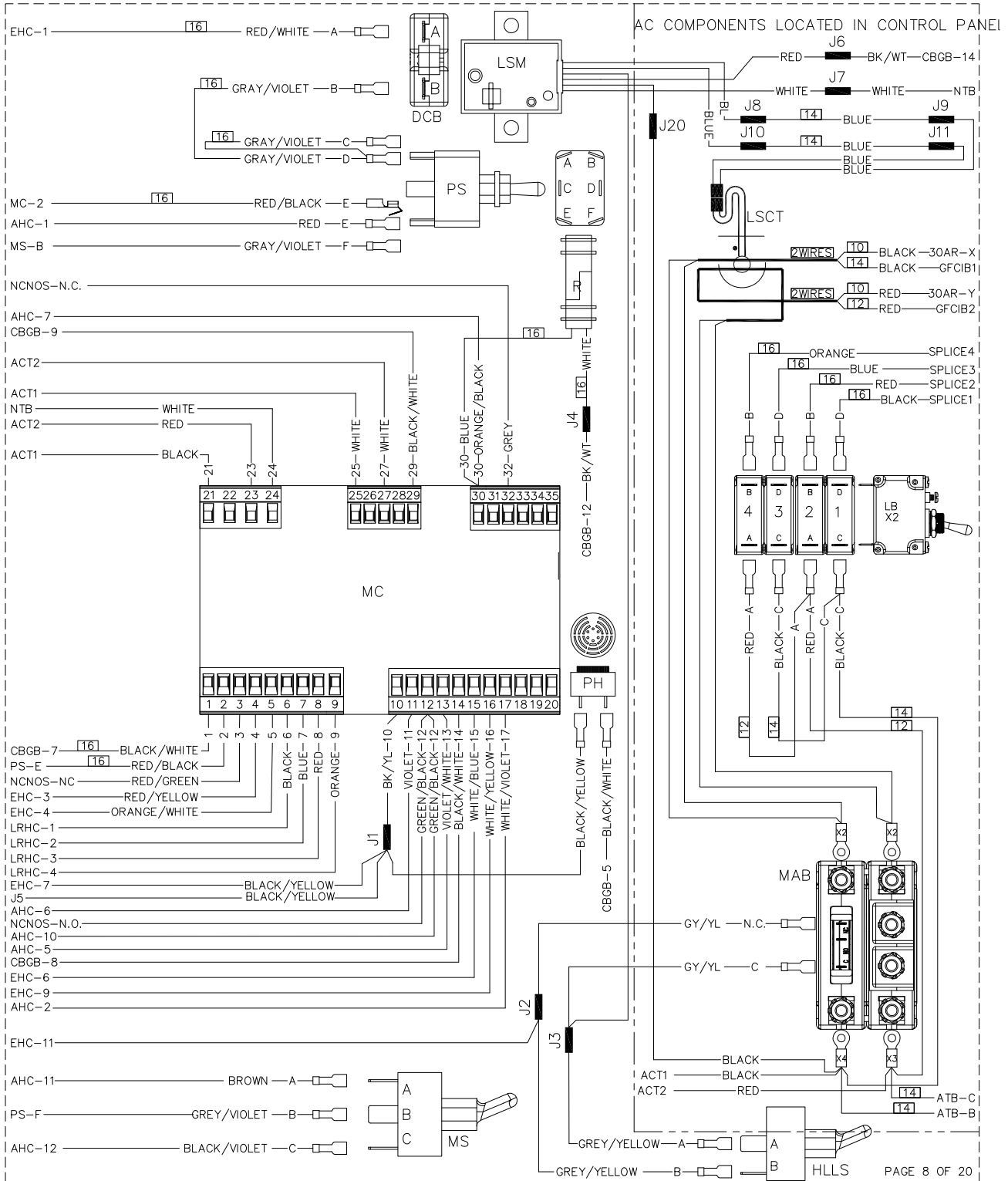

REVISION: D
DATE: 3/28/17

PAGE 8 OF 20

WIRING - DIAGRAM
MLT4060xVD
DRAWING #: 90681

AC Components in Control Panel and Alternator Box

GROUP G

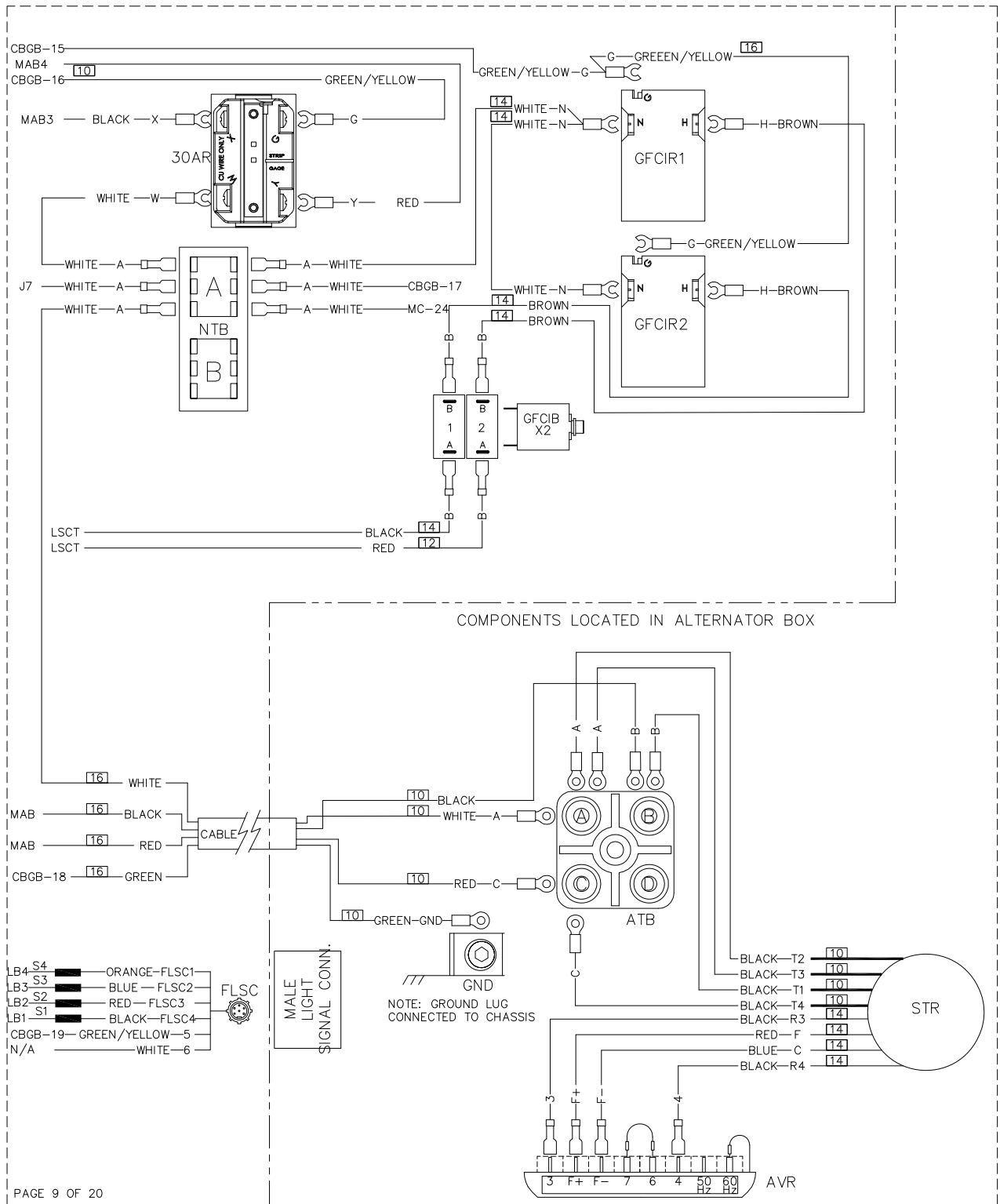

PAGE 9 OF 20

REVISION: D
DATE: 3/28/17

PAGE 9 OF 20

WIRING - DIAGRAM
MLT4060xVD
DRAWING #: 90681

Components Located in Mast Box

GROUP G

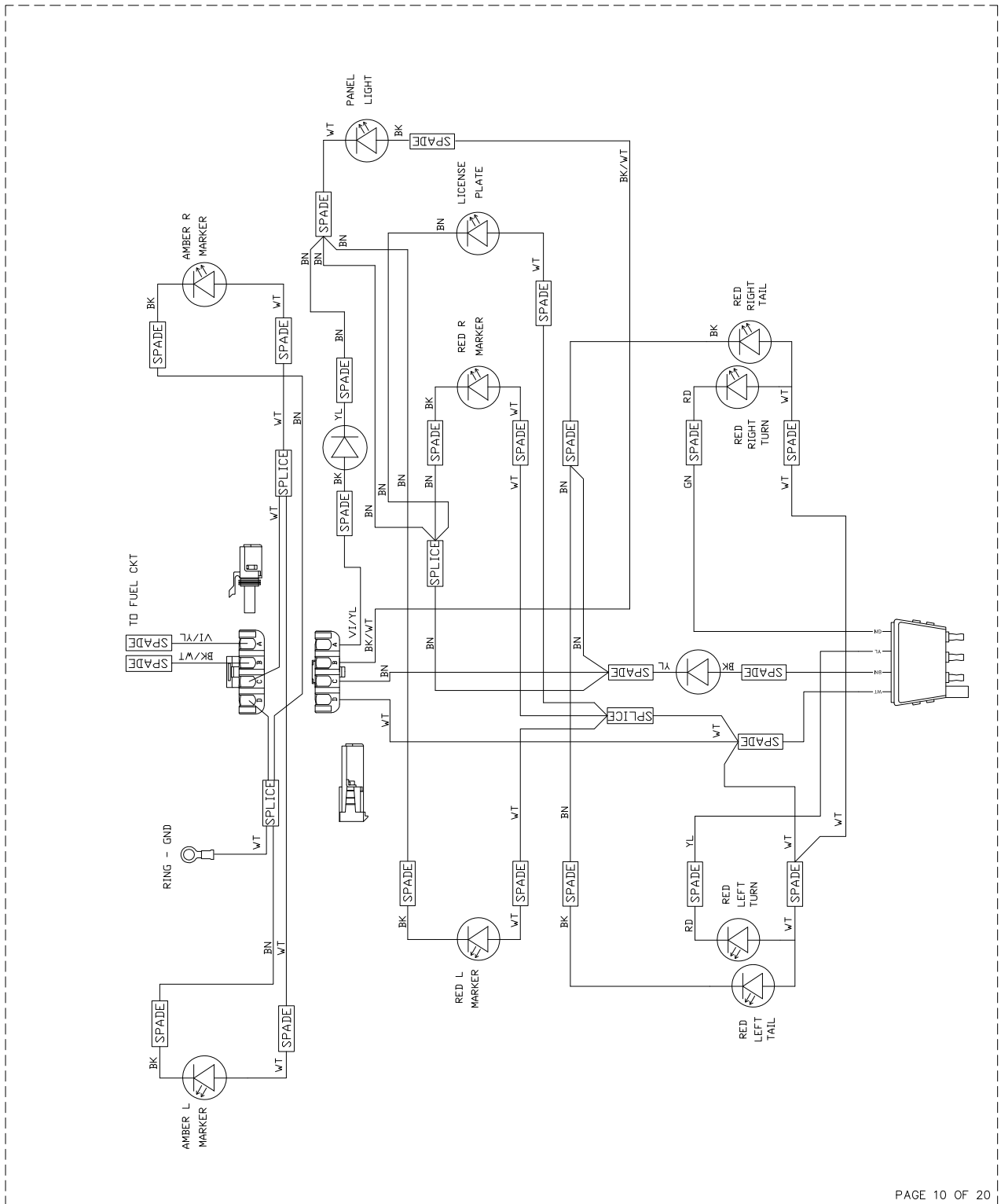

PAGE 10 OF 20

REVISION: D
DATE: 3/28/17

PAGE 10 OF 20

WIRING - DIAGRAM
MLT4060xVD
DRAWING #: 90681

Schematic Diagrams

Components Located in Mast Box

GROUP G

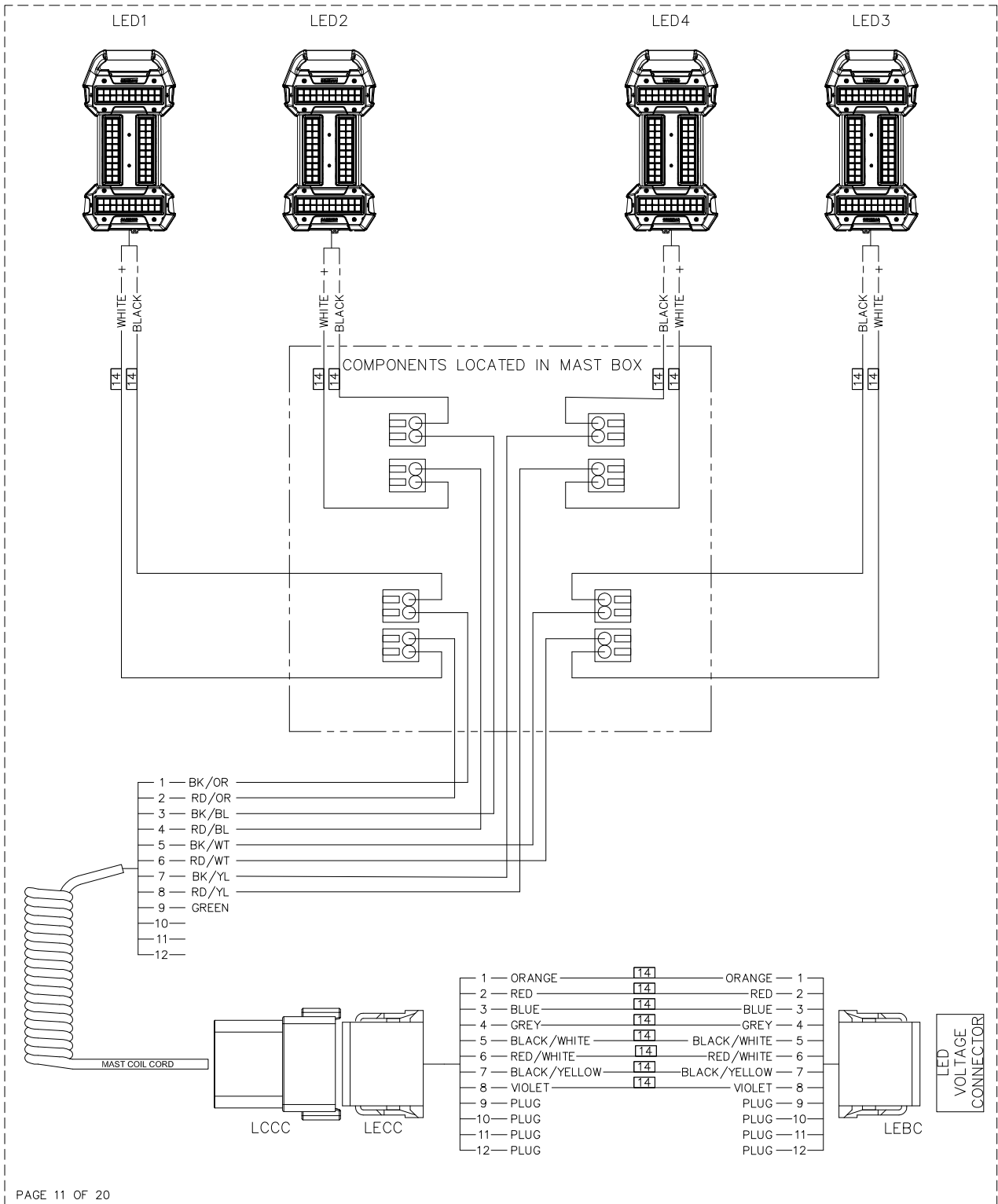

PAGE 11 OF 20

WIRING - DIAGRAM

REVISION: D
DATE: 3/28/17

PAGE 11 OF 20

MLT4060xVD

DRAWING #: 90681

Components Located in LED Box

GROUP G

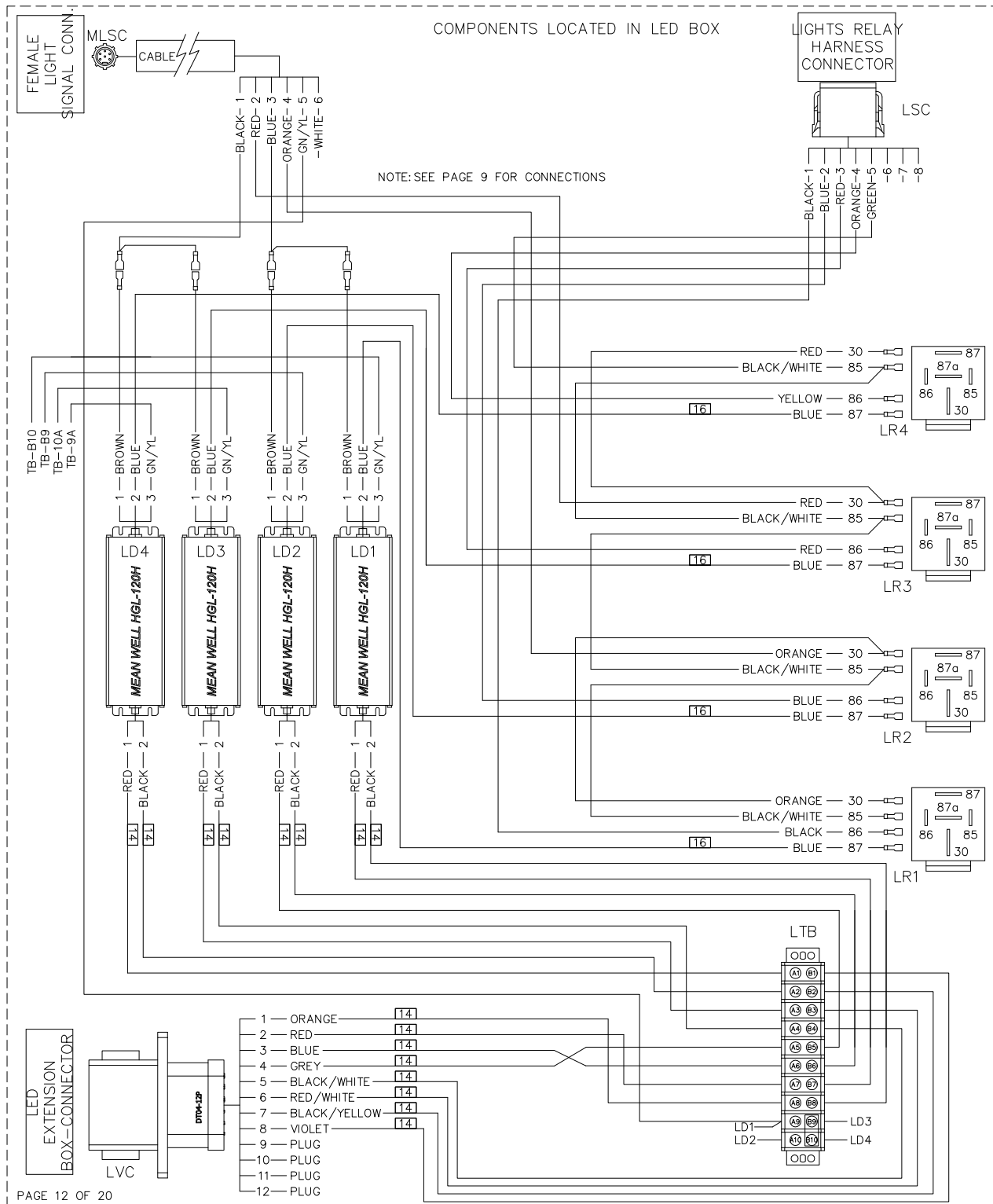

PAGE 12 OF 20

WIRING - DIAGRAM

MLT4060xVD

DRAWING #: 90681

REVISION: D
DATE: 3/28/17

PAGE 12 OF 20

Engine Control Module Connections

GROUP G

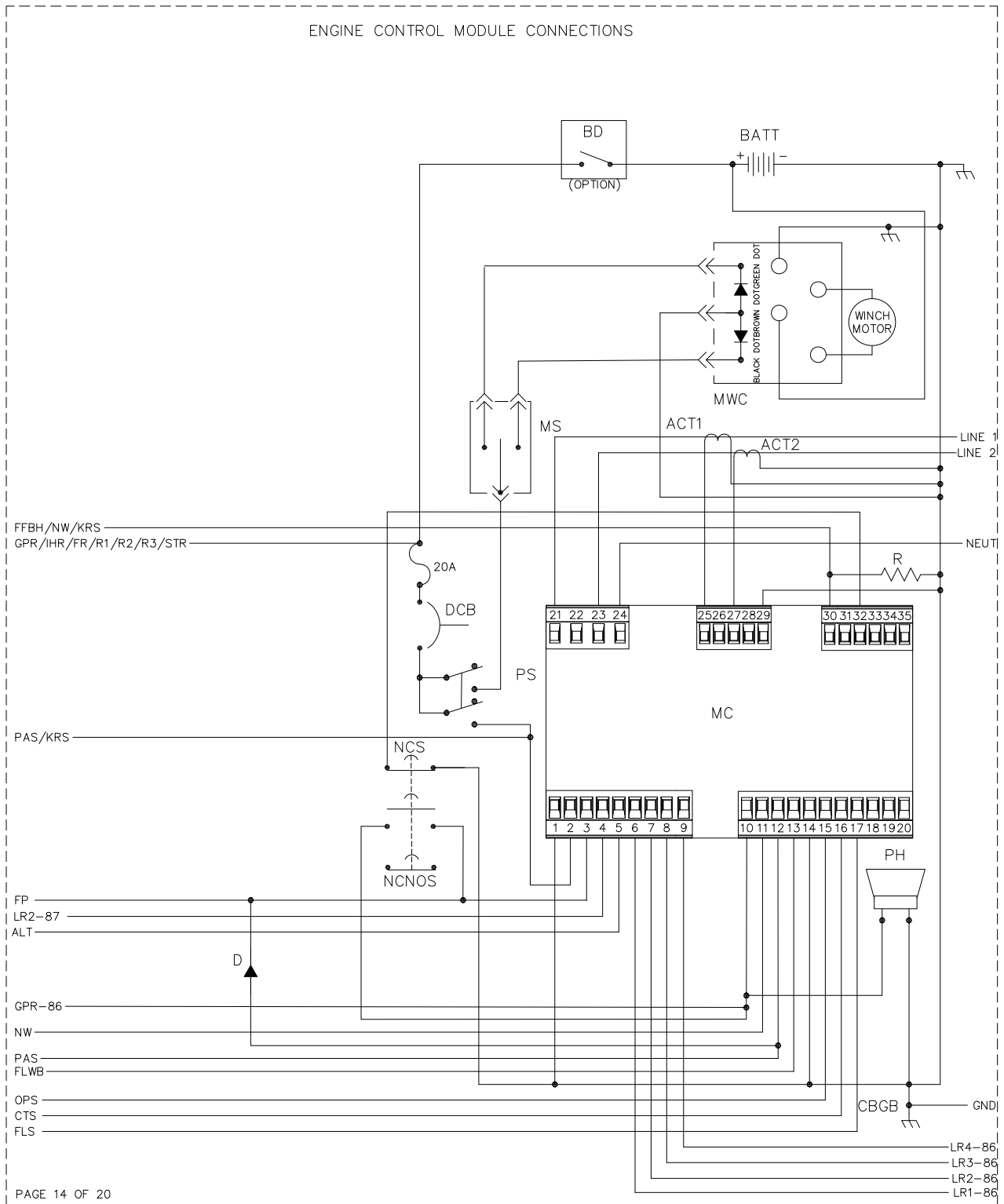

SCHMATIC - DIAGRAM

MLT4060xVD

DRAWING #: 90681

REVISION: D
DATE: 3/28/17

PAGE 14 OF 20

A/C Schematic

GROUP G

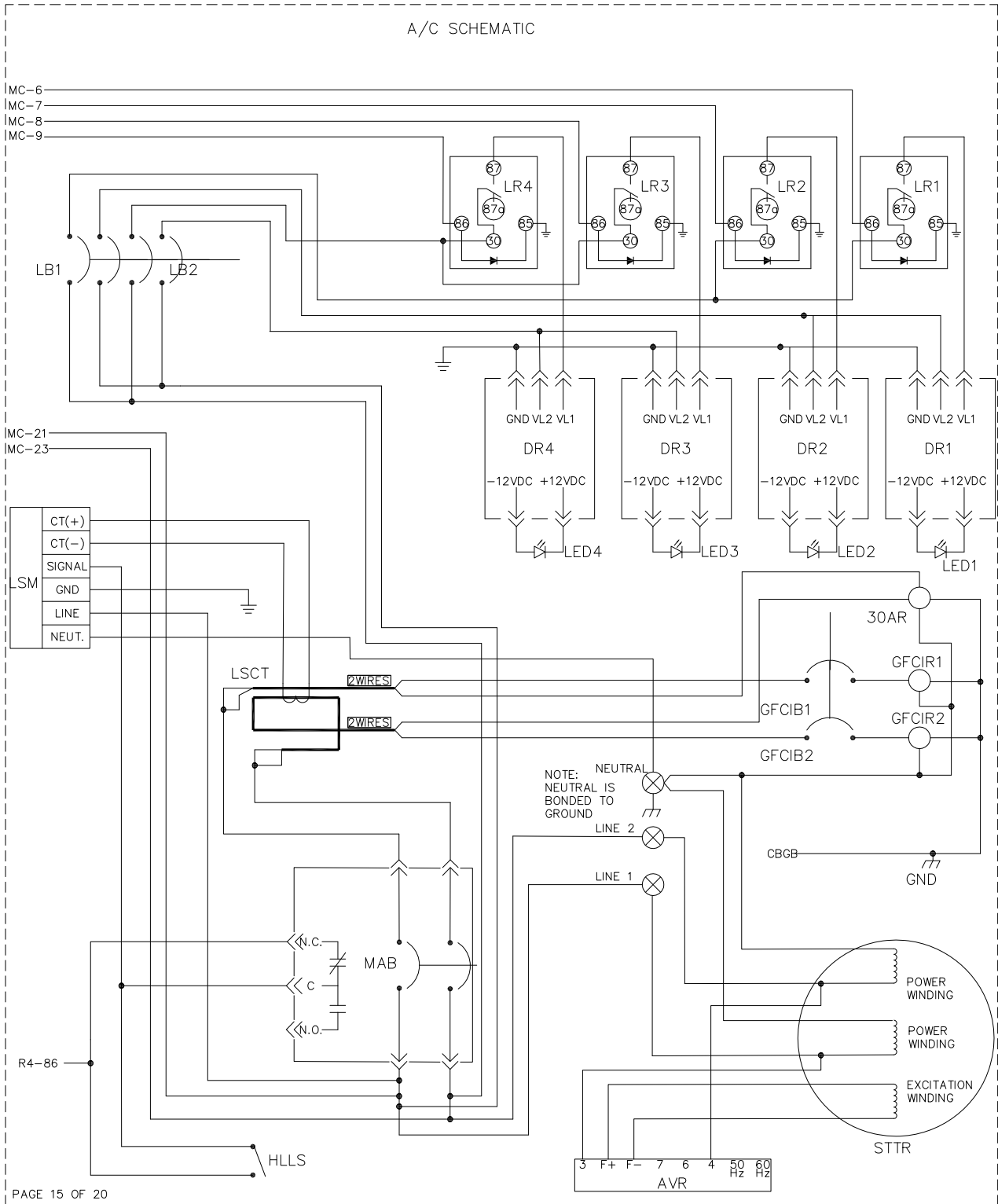

SHEMATIC - DIAGRAM

MLT4060xVD

DRAWING #: 90681

REVISION: D

DATE: 3/28/17

PAGE 15 OF 20

Relays (p. 1)

GROUP G

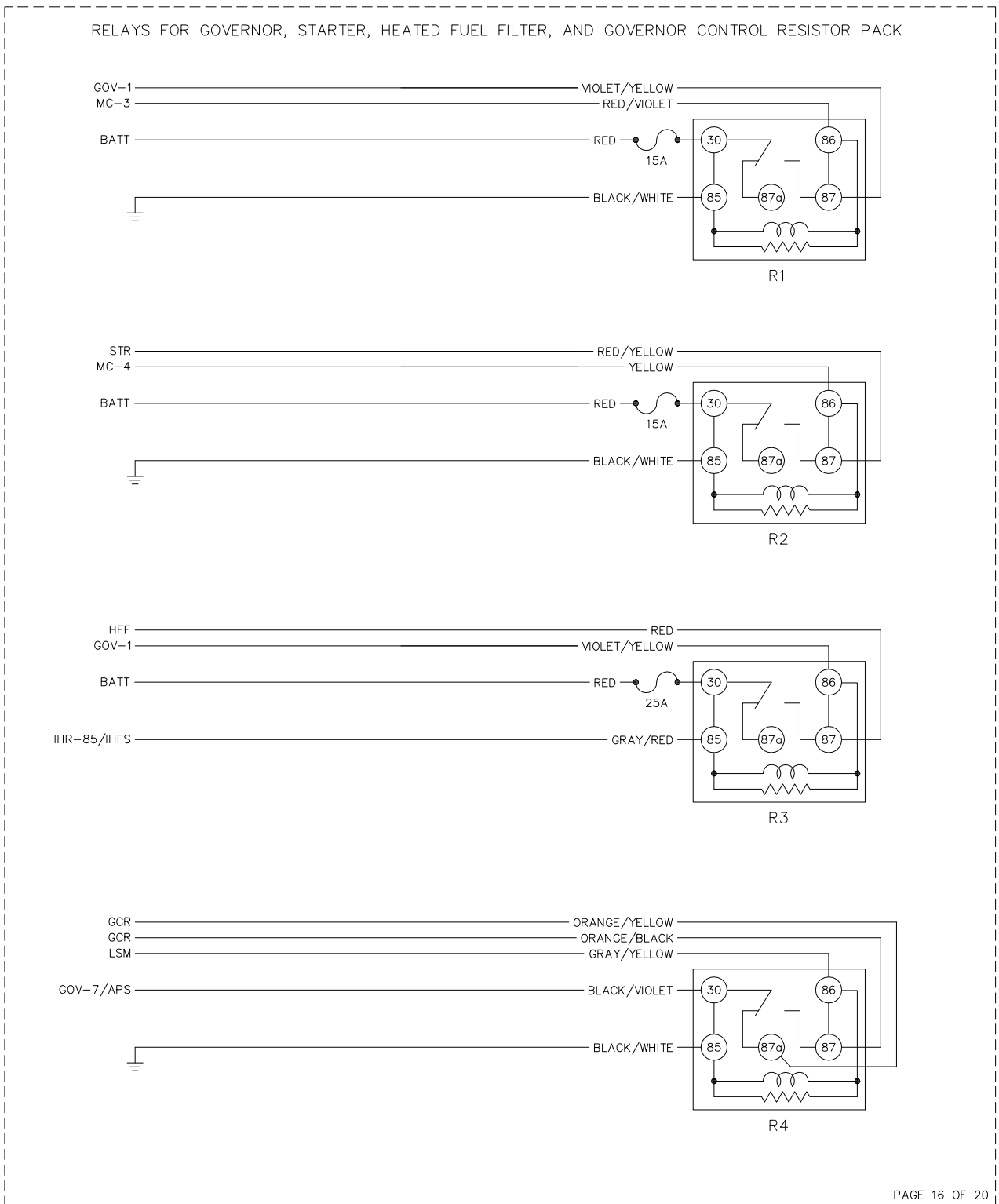

PAGE 16 OF 20

REVISION: D
DATE: 3/28/17

PAGE 16 OF 20

SCHEMATIC - DIAGRAM
MLT4060xVD
DRAWING #: 90681

Relays (p. 2)

GROUP G

RELAYS FOR GOVERNOR, STARTER, HEATED FUEL FILTER, AND GOVERNOR CONTROL RESISTOR PACK

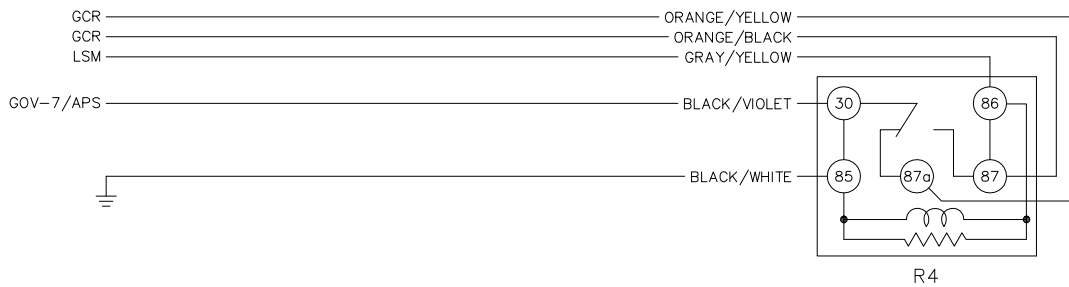
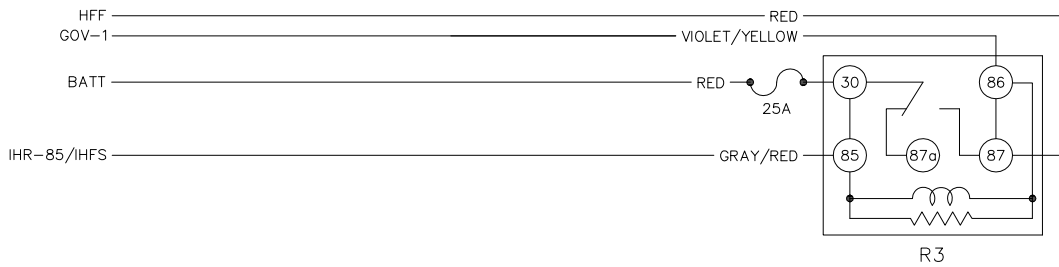
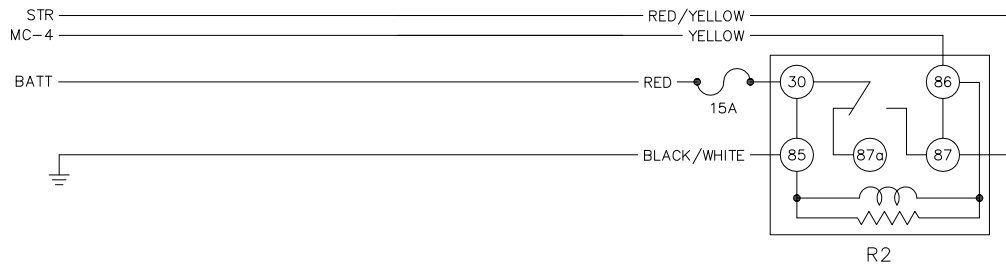
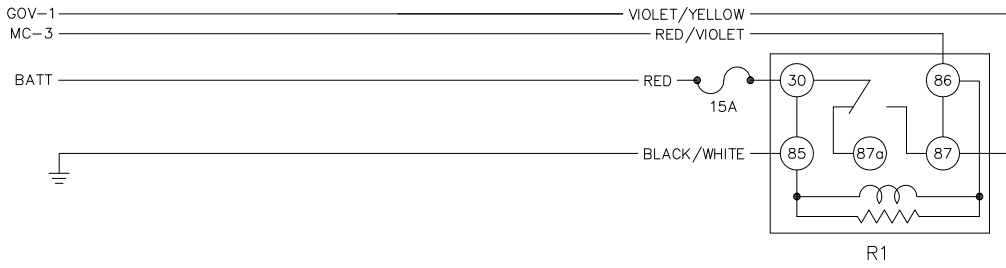

PAGE 16 OF 20

REVISION: D
DATE: 3/28/17

PAGE 16 OF 20

SCHMATIC - DIAGRAM
MLT4060xVD
DRAWING #: 90681

Relays (p. 3)

GROUP G

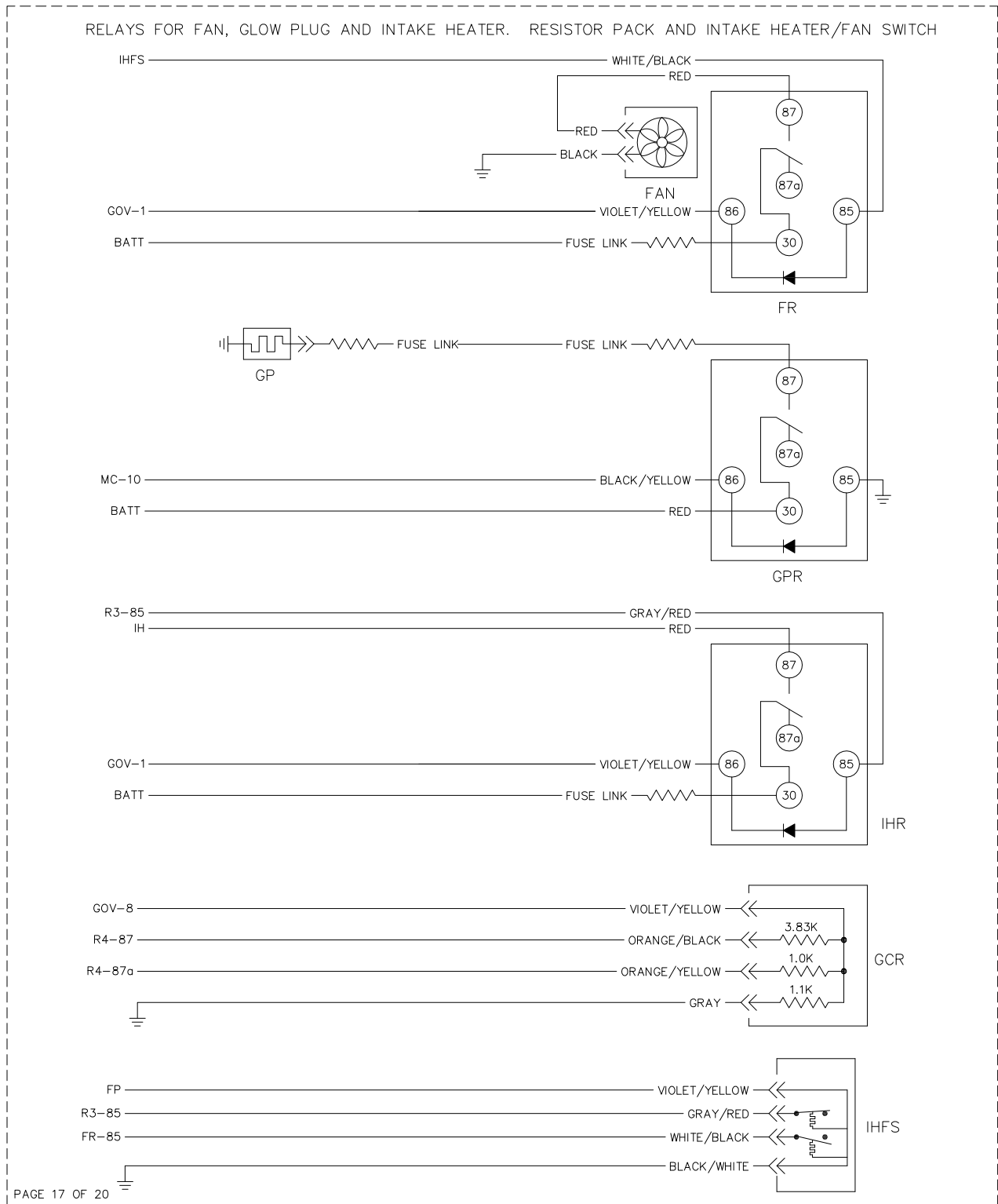

PAGE 17 OF 20

SCHEMATIC - DIAGRAM

REVISION: D
 DATE: 3/28/17

PAGE 17 OF 20

MLT4060xVD

DRAWING #: 90681

DC Connections (p. 1)

GROUP G

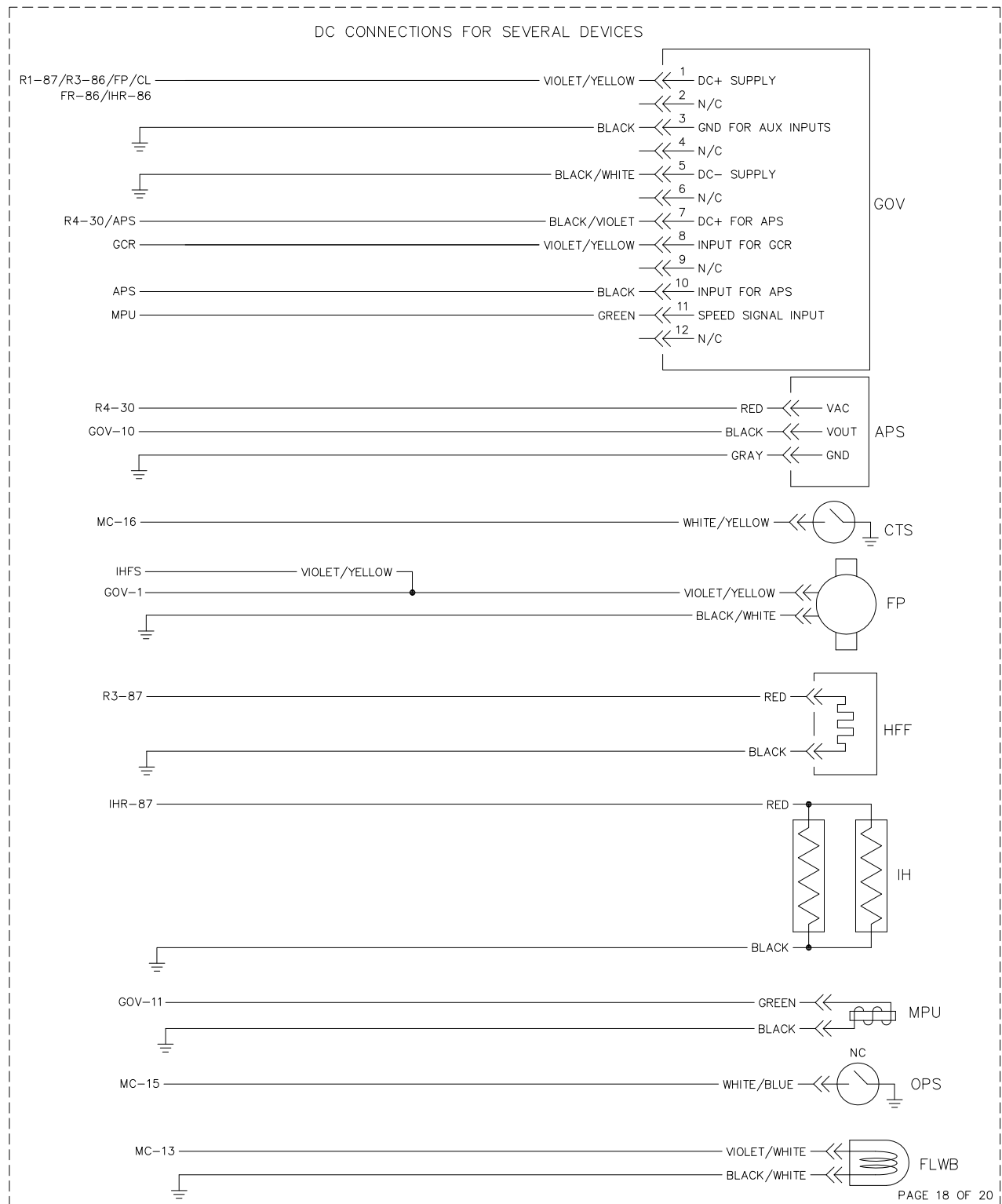

PAGE 18 OF 20

SCHEMATIC - DIAGRAM

MLT4060xVD

DRAWING #: 90681

REVISION: D
DATE: 3/28/17

PAGE 18 OF 20

DC Connections (p. 2)

GROUP G

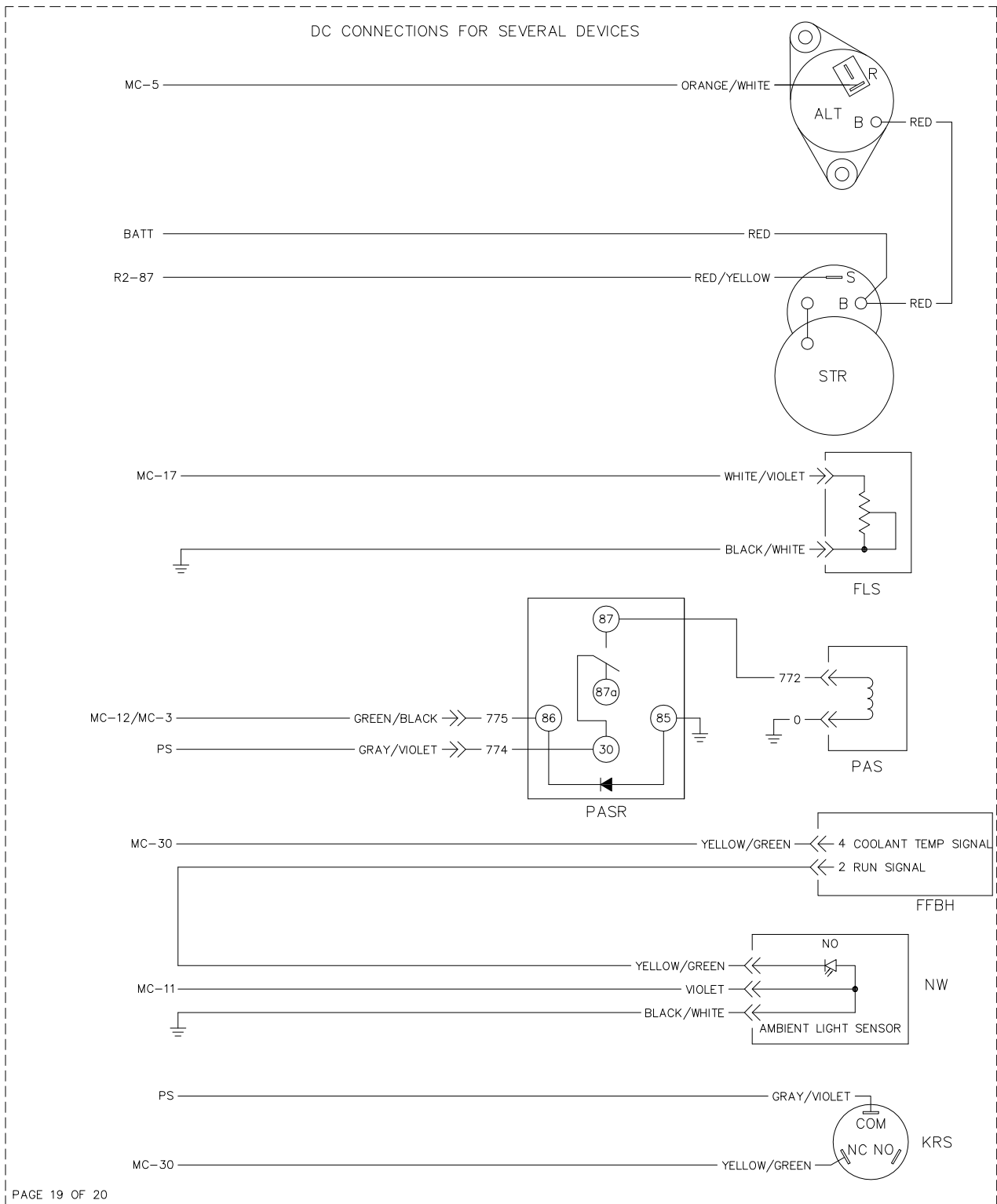

PAGE 19 OF 20

SCHEMATIC - DIAGRAM

REVISION: D
DATE: 3/28/17

PAGE 19 OF 20

MLT4060xVD

DRAWING #: 90681

GROUP G

PAGE LEFT BLANK INTENTIONALLY

PAGE 20 OF 20

REVISION: D
DATE: 3/28/17

PAGE 20 OF 20

SCHEMATIC - DIAGRAM
MLT4060xVD
DRAWING #: 90681

Service Log

Notes

OIL GRADE: _____

COOLANT MIXTURE: _____

Date	Hours to Service	Oil Level	Coolant Level

Part No. 72096 Rev. B 04/04/17
©2017 Generac Mobile Products
All rights reserved.
Specifications are subject to change without notice.
No reproduction allowed in any form without prior written
consent from Generac Mobile Products.

GENERAC®

MAGNUM

Generac Mobile Products
215 Power Drive, Berlin, WI 54923

GeneracMobileProducts.com | 800-926-9768 | 920-361-4442